

SERIE

A

CILINDRI COMPATTI UNITOP
UNITOP COMPACT CYLINDERS

ARTEC[®]
PNEUMATIC COMPONENTS

 **WC
BRANHAM**[®]
SOLUTIONS IN MOTION

CHIAVE DI CODIFICA

KEY CODE

A D M			0 5 0 . 0 3 0 . G S . F				
			ALESAGGIO - BORE (Ø)	CORSA - STROKE (mm)		OPZIONE - OPTION	
			012-016-020-025-032 040-050-063-080-100	vedere tabelle corse std see std stroke tables		EX ATEX  II 2GD cT4	
			VERSIONE - VERSION			STELO - ROD	
			A con staffa antirotazione with anti-rotation bracket			F femmina female	
			VERSIONE - VERSION			M maschio male	
			P stelo passante double rod			GUARNIZIONI - SEALS	
			VERSIONE - VERSION			GS guarnizioni standard standard seals	
			M magnetico magnetic			VR guarnizione stelo per alte temperature high temperature rod seal	
			non magnetico non-magnetic			VA tutte le guarnizioni per alte temperature all seals for high temperature	
			VERSIONE - VERSION				
			S semplice effetto molla anteriore single acting front spring				
			SE semplice effetto molla posteriore single acting rear spring				
			D doppio effetto double acting				
			SERIE - SERIES				
			A tubo profilato con cave per sensori tube with slots for sensors				

SERIE

A

ESECUZIONI A RICHIESTA - ON REQUEST

Stelo forato - *Hollow rod*

Stelo prolungato (W) - *Extended rod (W)*

Filetti speciali (dado stelo non fornito) - *Special thread (without rod nut)*

ATEX  II 2GD cT4

FORZE TEORICHE DI TRAZIONE (P=6bar)

THEORETICAL FORCES OF TRACTION (P=6bar)

		Ø	012-016	020	025	032	040	050	063	080	100
ADM	SPINTA THRUST [N]		121	189	295	483	753	1.178	1.870	3.016	4.712
	TRAZIONE TRACTION [N]		90	141	247	415	686	1.057	1.750	2.827	4.524
ADMA	SPINTA THRUST [N]		121	189	295	483	753	1.178	1.870	3.016	4.712
	TRAZIONE TRACTION [N]		90	141	247	415	686	1.057	1.750	2.827	4.524
ADMP	SPINTA THRUST [N]		90	141	247	415	686	1.057	1.750	2.827	4.524
	TRAZIONE TRACTION [N]		90	141	247	415	686	1.057	1.750	2.827	4.524
ADMPA	SPINTA THRUST [N]		90	141	247	415	686	1.057	1.750	2.827	4.524
	TRAZIONE TRACTION [N]		90	141	247	415	686	1.057	1.750	2.827	4.524

DIAGRAMMA TEORICO CARICO AMMISSIBILE

THEORETICAL ALLOWABLE LOAD

SERIE
A



DIAGRAMMA TEORICO CARICO AMMISSIBILE

THEORETICAL ALLOWABLE LOAD

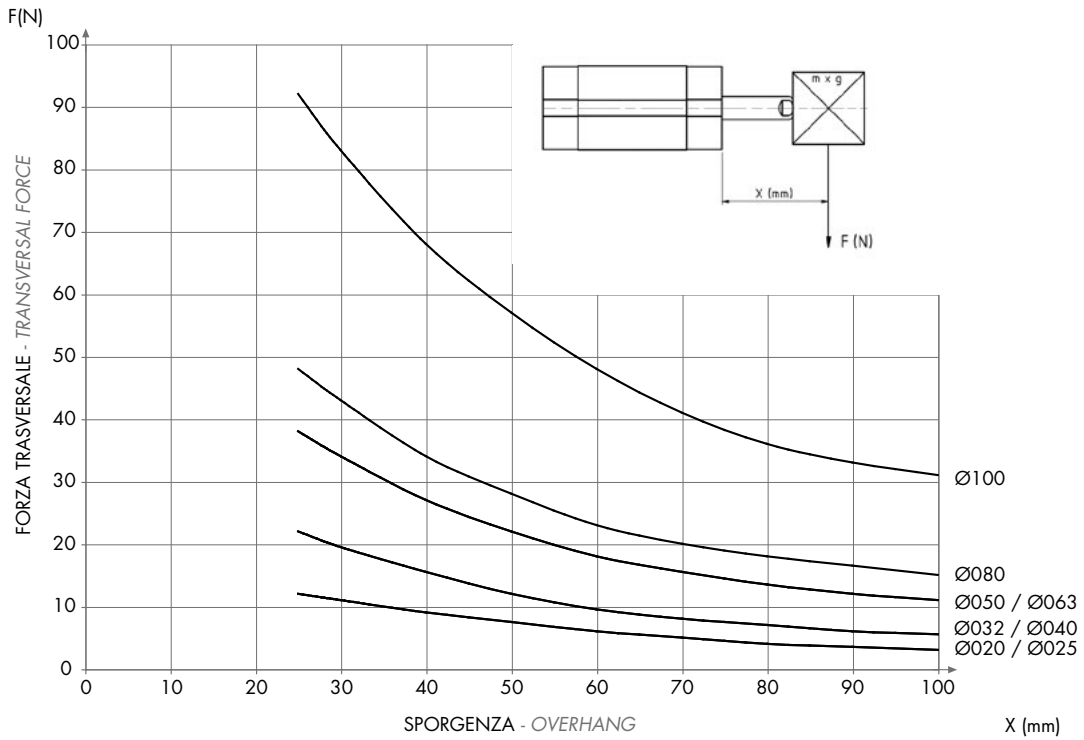

DIAGRAMMA TEORICO CARICO AMMISSIBILE

THEORETICAL ALLOWABLE LOAD

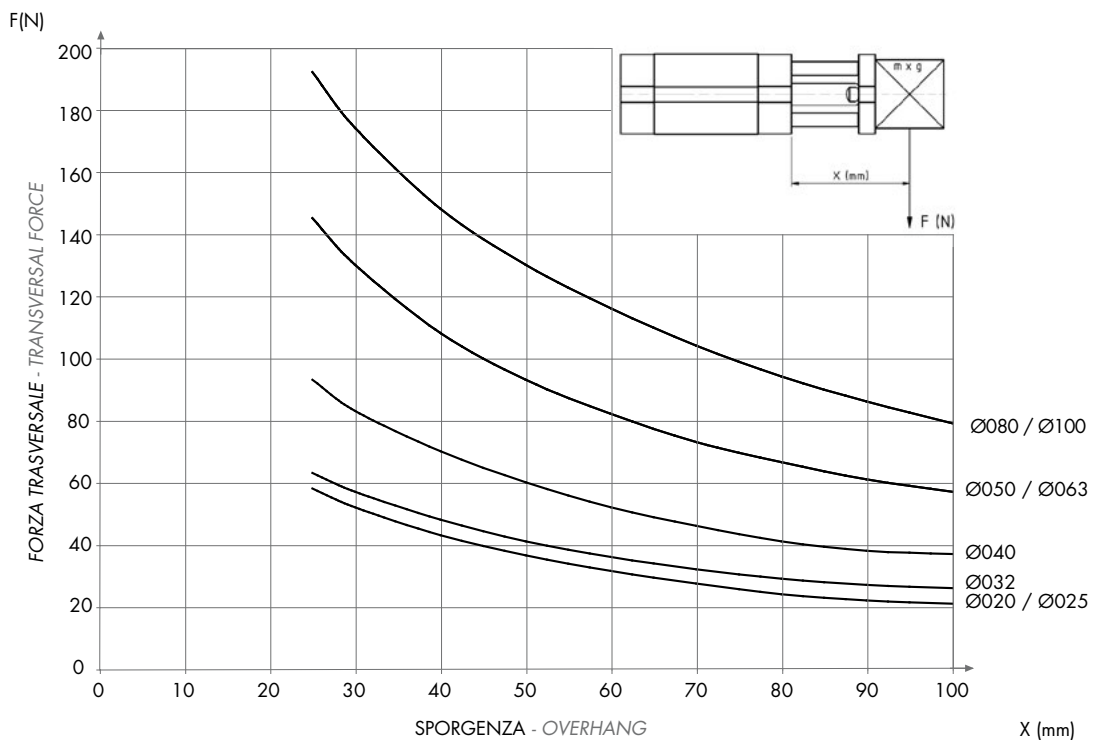
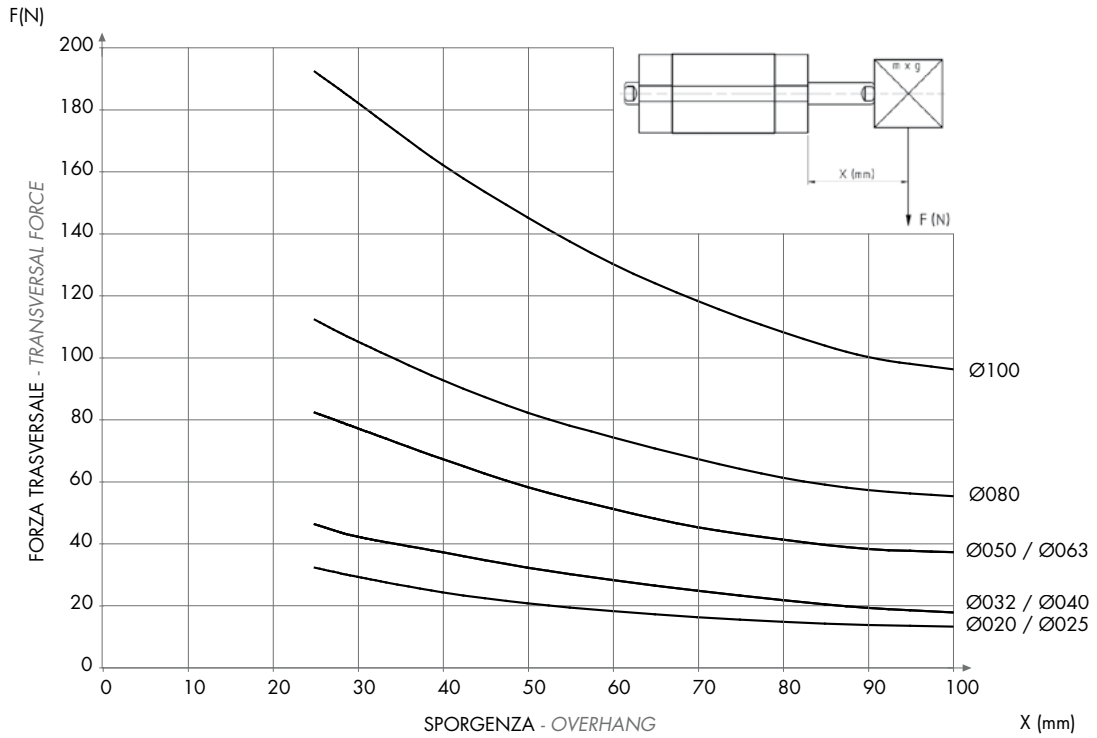

SERIE

A

DIAGRAMMA TEORICO COPPIA AMMISSIBILE

THEORETICAL ALLOWABLE TORQUE

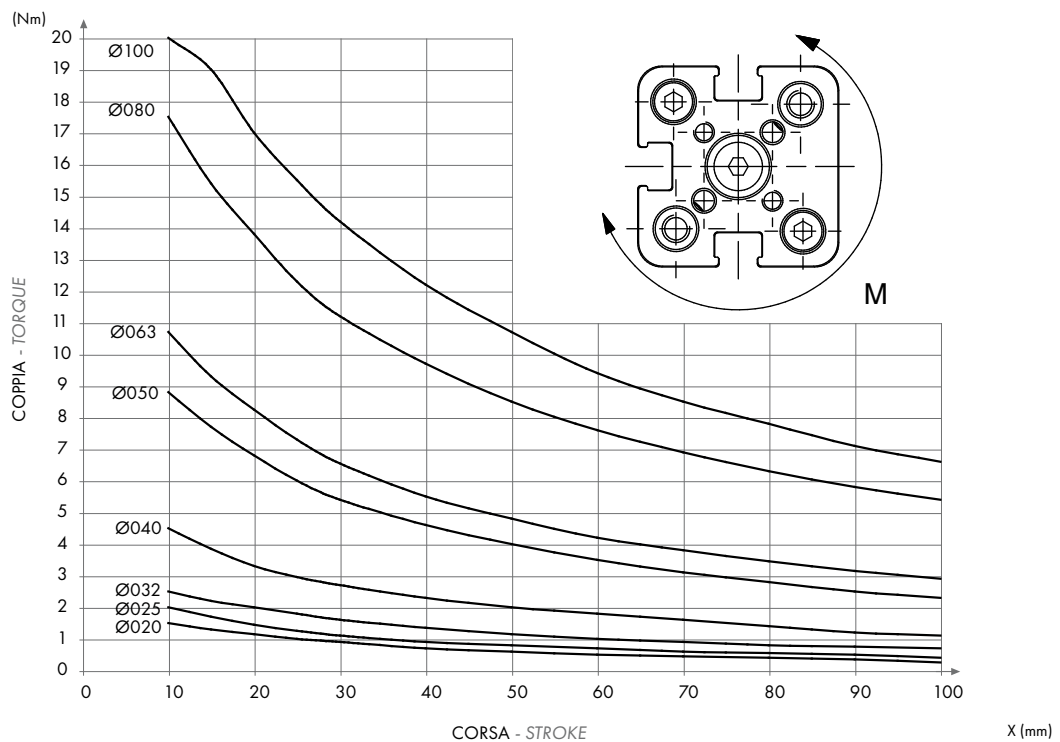

SEMPLICE EFFETTO MAGNETICO - MOLLA ANTERIORE

SINGLE ACTING MAGNETIC - FRONT SPRING

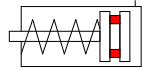

SERIE

A

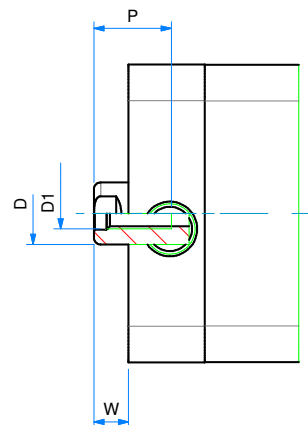
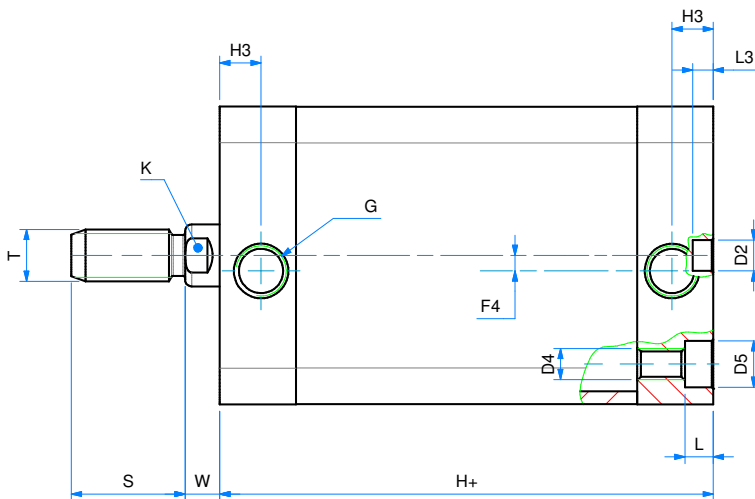
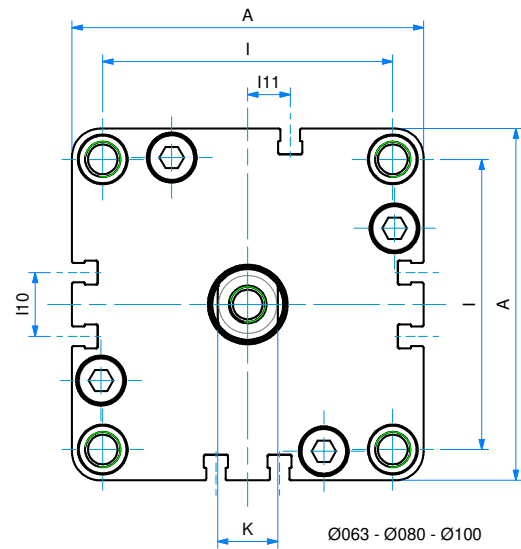
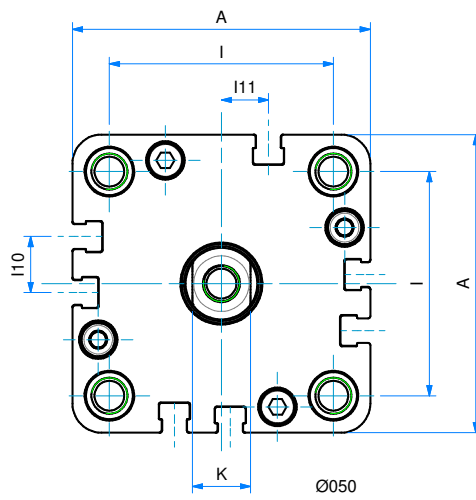
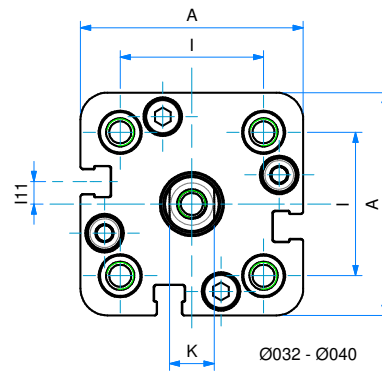
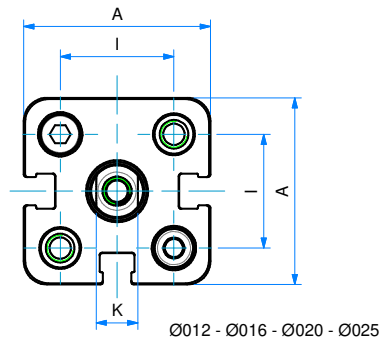

SEMPLICE EFFETTO MAGNETICO - MOLLA ANTERIORE
SINGLE ACTING MAGNETIC - FRONT SPRING

DIMENSIONI - DIMENSIONS										
Ø	012	016	020	025	032	040	050	063	080	100
A	29	29	36	40	50	58	67	80	100	124
Ø D	6	8	10	10	12	12	16	16	20	25
D1	M3	M4	M5	M5	M6	M6	M8	M8	M10	M12
Ø D2	6	6	6	6	6	6	6	8	8	8
D4	M4	M4	M5	M5	M6	M6	M8	M10	M10	M10
Ø D5	6	6	7,5	7,5	9	9	10,5	13,5	13,5	13,5
F4	-	-	-	-	4	3	-	-	-	-
G	M5	M5	M5	M5	G1/8	G1/8	G1/8	G1/8	G1/8	G1/4
H+	38*	38*	38*	39,5*	44,5*	45,5*	45,5*	50*	56*	66,5*
H3	8	8	8	8	8	8	8	8	8,5	10,5
I	18	18	22	26	32	42	50	62	82	103
I10	-	-	-	-	-	-	12,5	14	18	35
I11	-	-	-	-	5	3	10,5	12	12	17,5
K	5	6	8	8	10	10	13	13	17	22
L	3,5	3,5	4,5	4,5	5,5	5,5	6,5	8,5	8,5	8,5
L3	4	4	4	4	4	4	4	4	4	4
P	8	11	12	12	15	15	17	17	17	22
S	16	20	22	22	22	22	24	24	32	40
T	M6	M8	M10x1,25	M10x1,25	M10x1,25	M10x1,25	M12x1,25	M12x1,25	M16x1,5	M20x1,5
W	4,5	4,5	4,5	5,5	6	6,5	7,5	7,5	8	10

+ = aggiungere lunghezza corsa (mm) - add stroke length (mm)

* per corse - for strokes 035 - 040 - 050 - 060:

ASM 012 - 016 - 020 aggiungere - add +10 mm

ASM 025 - 032 - 040 - 050 - 063 aggiungere - add +20 mm

ASM 080 - 100 aggiungere - add +30 mm

Ø	CORSE STANDARD - STANDARD STROKES
012	5 - 10 - 15 - 20 - 25 - 30 - 35 - 40 - 50 - 60
016	5 - 10 - 15 - 20 - 25 - 30 - 35 - 40 - 50 - 60
020	5 - 10 - 15 - 20 - 25 - 30 - 35 - 40 - 50 - 60
025	5 - 10 - 15 - 20 - 25 - 30 - 35 - 40 - 50 - 60
032	5 - 10 - 15 - 20 - 25 - 30 - 35 - 40 - 50 - 60
040	5 - 10 - 15 - 20 - 25 - 30 - 35 - 40 - 50 - 60
050	5 - 10 - 15 - 20 - 25 - 30 - 35 - 40 - 50 - 60
063	5 - 10 - 15 - 20 - 25 - 30 - 35 - 40 - 50 - 60
080	5 - 10 - 15 - 20 - 25 - 30 - 35 - 40 - 50 - 60
100	5 - 10 - 15 - 20 - 25 - 30 - 35 - 40 - 50 - 60

SERIE

A

SEMPLICE EFFETTO MAGNETICO - MOLLA POSTERIORE

SINGLE ACTING MAGNETIC - REAR SPRING

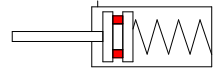

SERIE

A

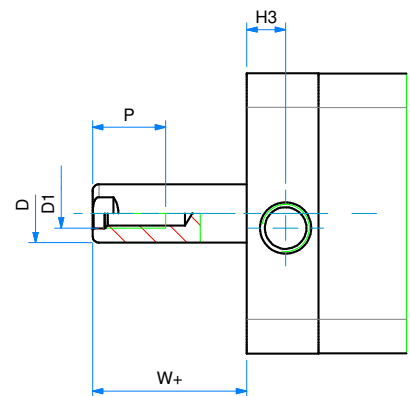
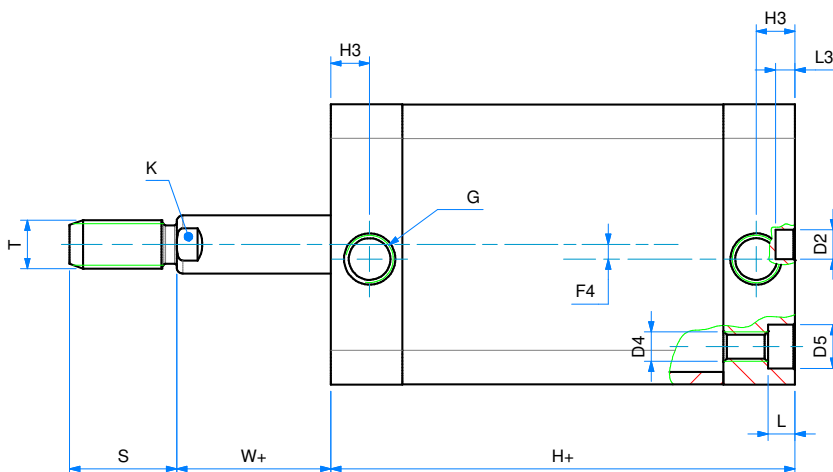
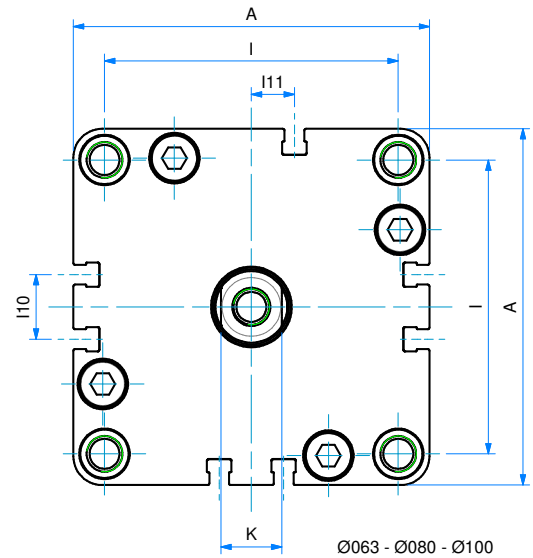
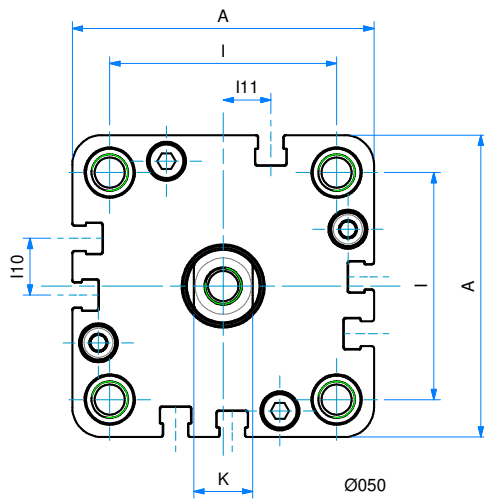
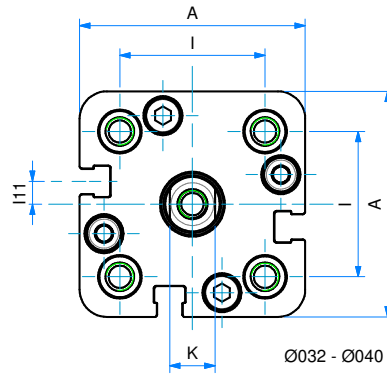
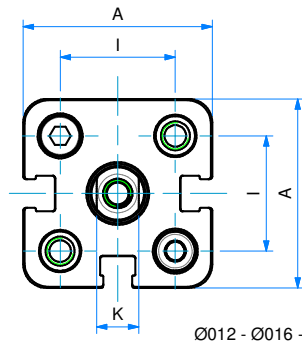

SEMPLICE EFFETTO MAGNETICO - MOLLA POSTERIORE
SINGLE ACTING MAGNETIC - REAR SPRING

DIMENSIONI - DIMENSIONS										
Ø	012	016	020	025	032	040	050	063	080	100
A	29	29	36	40	50	58	67	80	100	124
Ø D	6	8	10	10	12	12	16	16	20	25
D1	M3	M4	M5	M5	M6	M6	M8	M8	M10	M12
Ø D2	6	6	6	6	6	6	6	8	8	8
D4	M4	M4	M5	M5	M6	M6	M8	M10	M10	M10
Ø D5	6	6	7,5	7,5	9	9	10,5	13,5	13,5	13,5
F4	-	-	-	-	4	3	-	-	-	-
G	M5	M5	M5	M5	G1/8	G1/8	G1/8	G1/8	G1/8	G1/4
H+	38*	38*	38*	39,5*	44,5*	45,5*	45,5*	50*	56*	66,5*
H3	8	8	8	8	8	8	8	8	8,5	10,5
I	18	18	22	26	32	42	50	62	82	103
I10	-	-	-	-	-	-	12,5	14	18	35
I11	-	-	-	-	5	3	10,5	12	12	17,5
K	5	6	8	8	10	10	13	13	17	22
L	3,5	3,5	4,5	4,5	5,5	5,5	6,5	8,5	8,5	8,5
L3	4	4	4	4	4	4	4	4	4	4
P	8	11	12	12	15	15	17	17	17	22
S	16	20	22	22	22	22	24	24	32	40
T	M6	M8	M10x1,25	M10x1,25	M10x1,25	M10x1,25	M12x1,25	M12x1,25	M16x1.5	M20x1.5
W+	4,5	4,5	4,5	5,5	6	6,5	7,5	7,5	8	10

+ = aggiungere lunghezza corsa (mm) - add stroke length (mm)

* per corse - for strokes 035-040-050-060:

ASEM 012 - 016 - 020 - 025 - 032 - 040 - 050 - 063 aggiungere - add +10 mm

ASEM 080 - 100 aggiungere - add +20 mm

Ø	CORSE STANDARD - STANDARD STROKES
012	5 - 10 - 15 - 20 - 25 - 30 - 35 - 40 - 50 - 60
016	5 - 10 - 15 - 20 - 25 - 30 - 35 - 40 - 50 - 60
020	5 - 10 - 15 - 20 - 25 - 30 - 35 - 40 - 50 - 60
025	5 - 10 - 15 - 20 - 25 - 30 - 35 - 40 - 50 - 60
032	5 - 10 - 15 - 20 - 25 - 30 - 35 - 40 - 50 - 60
040	5 - 10 - 15 - 20 - 25 - 30 - 35 - 40 - 50 - 60
050	5 - 10 - 15 - 20 - 25 - 30 - 35 - 40 - 50 - 60
063	5 - 10 - 15 - 20 - 25 - 30 - 35 - 40 - 50 - 60
080	5 - 10 - 15 - 20 - 25 - 30 - 35 - 40 - 50 - 60
100	5 - 10 - 15 - 20 - 25 - 30 - 35 - 40 - 50 - 60

SERIE

A

DOPPIO EFFETTO MAGNETICO

DOUBLE ACTING MAGNETIC

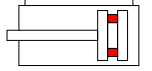

SERIE

A

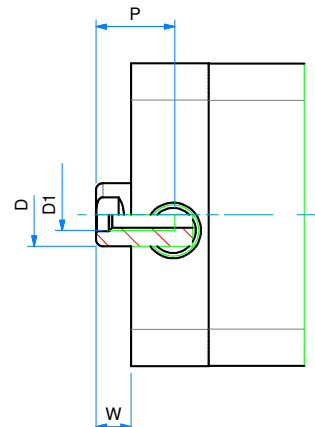
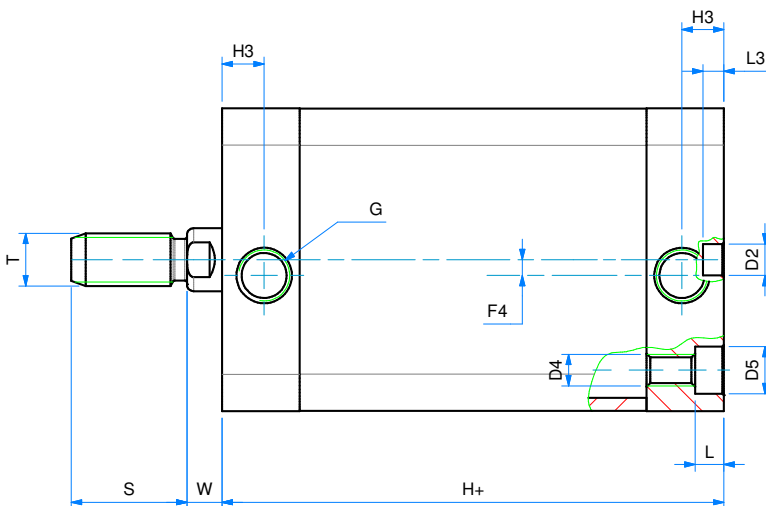
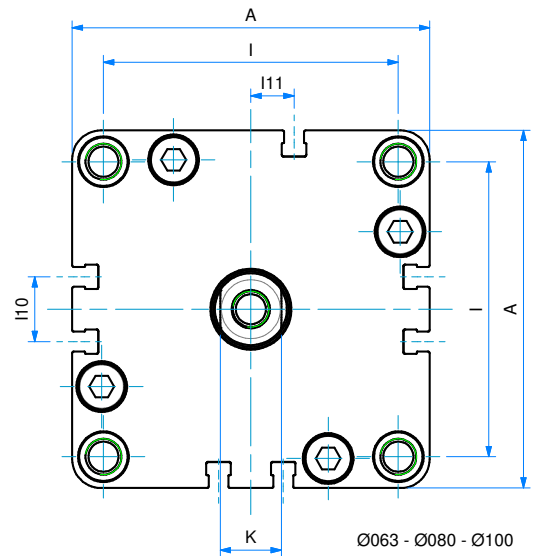
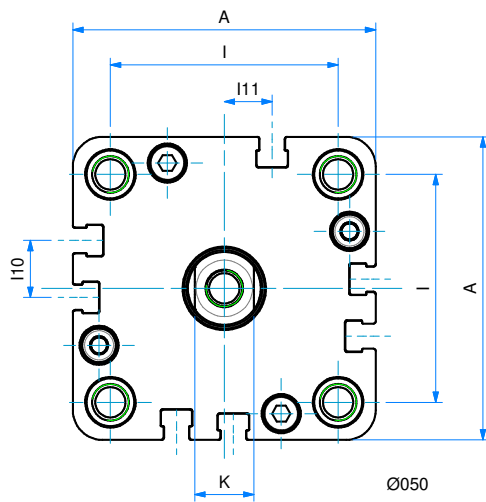
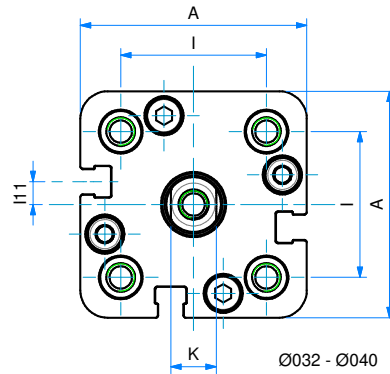
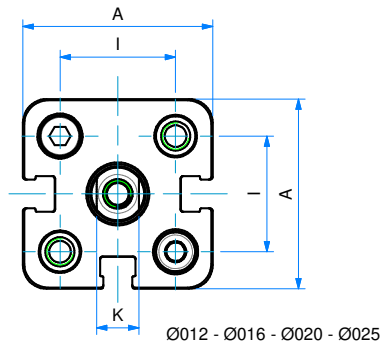

DOPPIO EFFETTO MAGNETICO
DOUBLE ACTING MAGNETIC

DIMENSIONI - DIMENSIONS										
Ø	012	016	020	025	032	040	050	063	080	100
A	29	29	36	40	50	58	67	80	100	124
Ø D	6	8	10	10	12	12	16	16	20	25
D1	M3	M4	M5	M5	M6	M6	M8	M8	M10	M12
Ø D2	6	6	6	6	6	6	6	8	8	8
D4	M4	M4	M5	M5	M6	M6	M8	M10	M10	M10
Ø D5	6	6	7,5	7,5	9	9	10,5	13,5	13,5	13,5
F4	-	-	-	-	4	3	-	-	-	-
G	M5	M5	M5	M5	G1/8	G1/8	G1/8	G1/8	G1/8	G1/4
H+	38	38	38	39,5	44,5	45,5	45,5	50	56	66,5
H3	8	8	8	8	8	8	8	8	8,5	10,5
I	18	18	22	26	32	42	50	62	82	103
I10	-	-	-	-	-	-	12,5	14	18	35
I11	-	-	-	-	5	3	10,5	12	12	17,5
K	5	6	8	8	10	10	13	13	17	22
L	3,5	3,5	4,5	4,5	5,5	5,5	6,5	8,5	8,5	8,5
L3	4	4	4	4	4	4	4	4	4	4
P	8	11	12	12	15	15	17	17	17	22
S	16	20	22	22	22	22	24	24	32	40
T	M6	M8	M10x1,25	M10x1,25	M10x1,25	M10x1,25	M12x1,25	M12x1,25	M16x1.5	M20x1.5
W	4,5	4,5	4,5	5,5	6	6,5	7,5	7,5	8	10

+ = aggiungere lunghezza corsa (mm) - add stroke length (mm)

Ø	CORSE STANDARD - STANDARD STROKES
012	5 - 10 - 15 - 20 - 25 - 30 - 40 - 50 - 60 - 70 - 75 - 80 - 90 - 100 - 125 - 160 - 200 - 250
016	5 - 10 - 15 - 20 - 25 - 30 - 40 - 50 - 60 - 70 - 75 - 80 - 90 - 100 - 125 - 160 - 200 - 250
020	5 - 10 - 15 - 20 - 25 - 30 - 40 - 50 - 60 - 70 - 75 - 80 - 90 - 100 - 125 - 160 - 200 - 250
025	5 - 10 - 15 - 20 - 25 - 30 - 40 - 50 - 60 - 70 - 75 - 80 - 90 - 100 - 125 - 160 - 200 - 250
032	5 - 10 - 15 - 20 - 25 - 30 - 40 - 50 - 60 - 70 - 75 - 80 - 90 - 100 - 125 - 160 - 200 - 250 - 300 - 350 - 400
040	5 - 10 - 15 - 20 - 25 - 30 - 40 - 50 - 60 - 70 - 75 - 80 - 90 - 100 - 125 - 160 - 200 - 250 - 300 - 350 - 400
050	5 - 10 - 15 - 20 - 25 - 30 - 40 - 50 - 60 - 70 - 75 - 80 - 90 - 100 - 125 - 160 - 200 - 250 - 300 - 350 - 400
063	5 - 10 - 15 - 20 - 25 - 30 - 40 - 50 - 60 - 70 - 75 - 80 - 90 - 100 - 125 - 160 - 200 - 250 - 300 - 350 - 400
080	5 - 10 - 15 - 20 - 25 - 30 - 40 - 50 - 60 - 70 - 75 - 80 - 90 - 100 - 125 - 160 - 200 - 250 - 300 - 350 - 400
100	5 - 10 - 15 - 20 - 25 - 30 - 40 - 50 - 60 - 70 - 75 - 80 - 90 - 100 - 125 - 160 - 200 - 250 - 300 - 350 - 400

 SERIE
A

DOPPIO EFFETTO MAGNETICO ANTIROTAZIONE

DOUBLE ACTING MAGNETIC ANTI-ROTATION

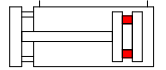

SERIE

A

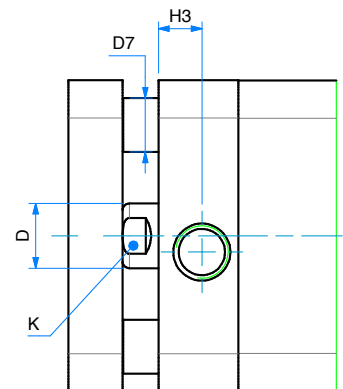
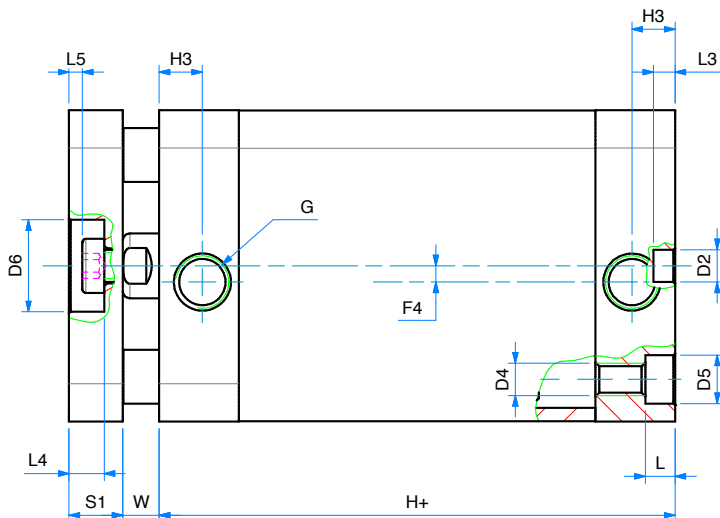
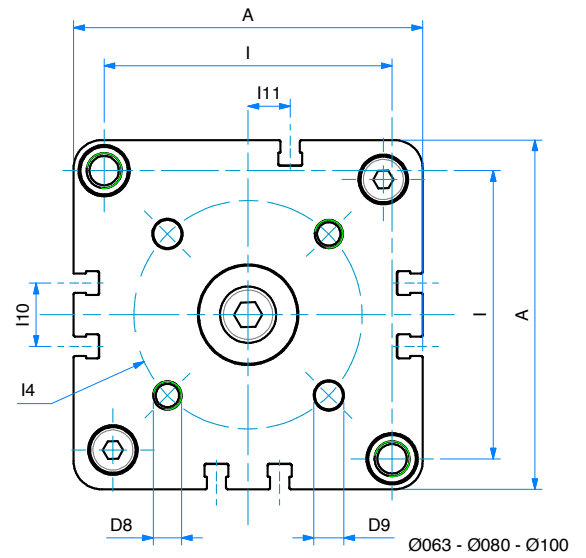
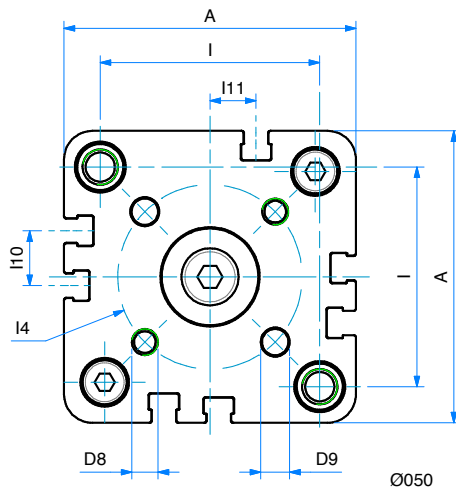
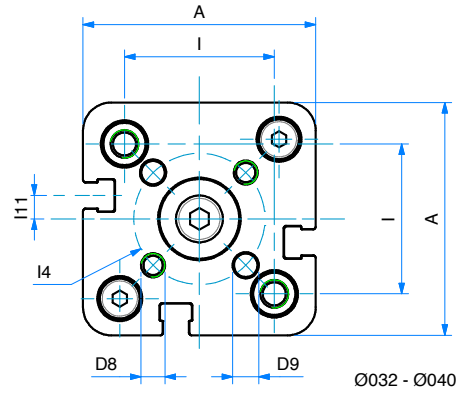
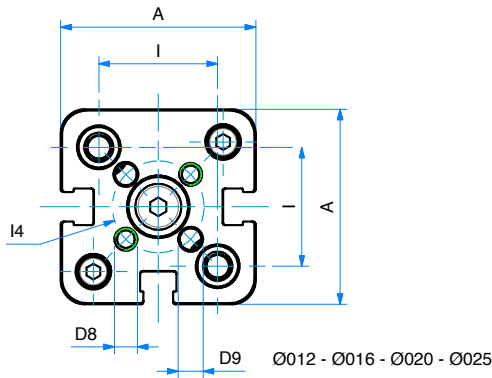

DOPPIO EFFETTO MAGNETICO ANTIROTAZIONE
DOUBLE ACTING MAGNETIC ANTI-ROTATION

DIMENSIONI - DIMENSIONS									
Ø	016	020	025	032	040	050	063	080	100
A	29	36	40	50	58	67	80	100	124
Ø D	8	10	10	12	12	16	16	20	25
Ø D2	6	6	6	6	6	6	8	8	8
D4	M4	M5	M5	M6	M6	M8	M10	M10	M10
Ø D5	6	7,5	7,5	9	9	10,5	13,5	13,5	13,5
Ø D6	9	11	14	17	17	22	22	28	30
Ø D7	5	5	6	8	10	10	10	14	14
D8	M3	M4	M5	M5	M5	M6	M6	M8	M10
Ø D9	3	4	5	5	5	6	6	8	10
F4	-	-	-	4	3	-	-	-	-
G	M5	M5	M5	G1/8	G1/8	G1/8	G1/8	G1/8	G1/4
H+	38	38	39,5	44,5	45,5	45,5	50	56	66,5
H3	8	8	8	8	8	8	8	8,5	10,5
I	18	22	26	32	42	50	62	82	103
I4	14	17	22	28	33	42	50	65	80
I10	-	-	-	-	-	12,5	14	18	35
I11	-	-	-	5	3	10,5	12	12	17,5
K	6	8	8	10	10	13	13	17	22
L	3,5	4,5	4,5	5,5	5,5	6,5	8,5	8,5	8,5
L3	4	4	4	4	4	4	4	4	4
L4	3,8	5	5	6,5	6,5	7,5	7,5	9	10
L5	1	1,5	1,5	2,5	2,5	2,5	2,5	3	3
S1	6	8	8	10	10	12	12	14	14
W	4,5	4,5	5,5	6	6,5	7,5	7,5	8	10

+ = aggiungere lunghezza corsa (mm) - add stroke length (mm)

Ø	CORSE STANDARD - STANDARD STROKES
016	5 - 10 - 15 - 20 - 25 - 30 - 40 - 50 - 60 - 70 - 75 - 80 - 90 - 100 - 125 - 160 - 200
020	5 - 10 - 15 - 20 - 25 - 30 - 40 - 50 - 60 - 70 - 75 - 80 - 90 - 100 - 125 - 160 - 200
025	5 - 10 - 15 - 20 - 25 - 30 - 40 - 50 - 60 - 70 - 75 - 80 - 90 - 100 - 125 - 160 - 200
032	5 - 10 - 15 - 20 - 25 - 30 - 40 - 50 - 60 - 70 - 75 - 80 - 90 - 100 - 125 - 160 - 200 - 250 - 300 - 350 - 400
040	5 - 10 - 15 - 20 - 25 - 30 - 40 - 50 - 60 - 70 - 75 - 80 - 90 - 100 - 125 - 160 - 200 - 250 - 300 - 350 - 400
050	5 - 10 - 15 - 20 - 25 - 30 - 40 - 50 - 60 - 70 - 75 - 80 - 90 - 100 - 125 - 160 - 200 - 250 - 300 - 350 - 400
063	5 - 10 - 15 - 20 - 25 - 30 - 40 - 50 - 60 - 70 - 75 - 80 - 90 - 100 - 125 - 160 - 200 - 250 - 300 - 350 - 400
080	5 - 10 - 15 - 20 - 25 - 30 - 40 - 50 - 60 - 70 - 75 - 80 - 90 - 100 - 125 - 160 - 200 - 250 - 300 - 350 - 400
100	5 - 10 - 15 - 20 - 25 - 30 - 40 - 50 - 60 - 70 - 75 - 80 - 90 - 100 - 125 - 160 - 200 - 250 - 300 - 350 - 400

SERIE
A

DOPPIO EFFETTO MAGNETICO STELO PASSANTE

DOUBLE ACTING MAGNETIC WITH DOUBLE ROD

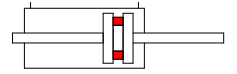

SERIE

A

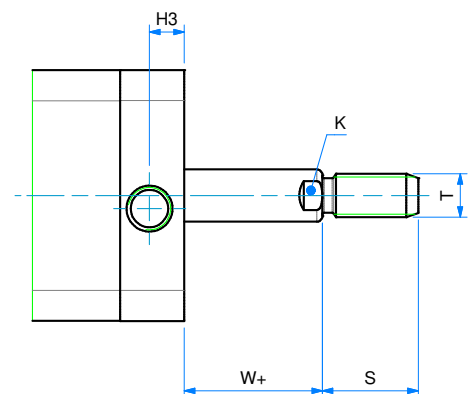
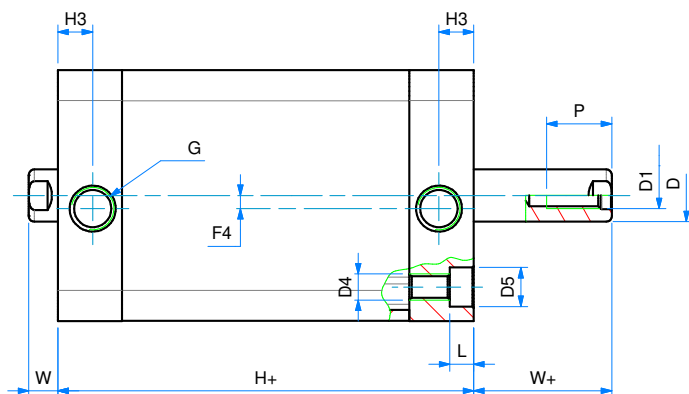
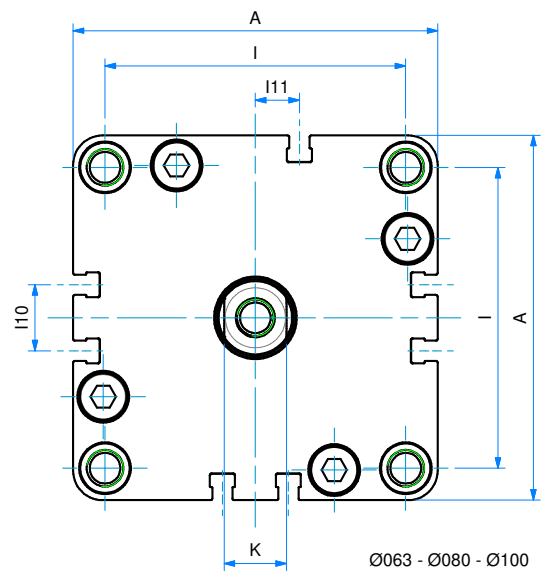
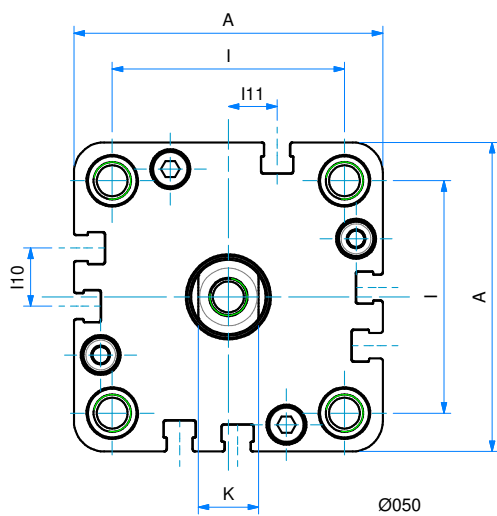
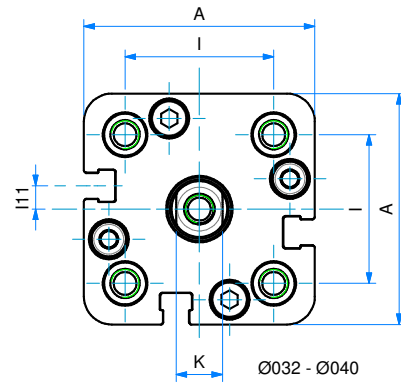
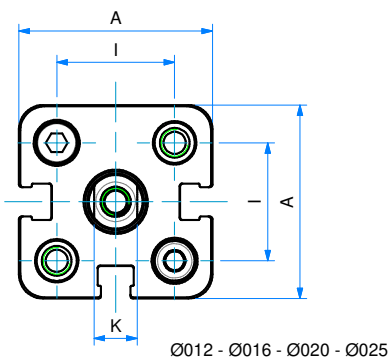

DOPPIO EFFETTO MAGNETICO STELO PASSANTE
DOUBLE ACTING MAGNETIC WITH DOUBLE ROD

DIMENSIONI - DIMENSIONS										
Ø	012	016	020	025	032	040	050	063	080	100
A	29	29	36	40	50	58	67	80	100	124
Ø D	6	8	10	10	12	12	16	16	20	25
D1	M3	M4	M5	M5	M6	M6	M8	M8	M10	M12
D4	M4	M4	M5	M5	M6	M6	M8	M10	M10	M10
Ø D5	6	6	7,5	7,5	9	9	10,5	13,5	13,5	13,5
F4	-	-	-	-	4	3	-	-	-	-
G	M5	M5	M5	M5	G1/8	G1/8	G1/8	G1/8	G1/8	G1/4
H+	38	38	38	39,5	44,5	45,5	45,5	50	56	66,5
H3	8	8	8	8	8	8	8	8	8,5	10,5
I	18	18	22	26	32	42	50	62	82	103
I10	-	-	-	-	-	-	12,5	14	18	35
I11	-	-	-	-	5	3	10,5	12	12	17,5
K	5	6	8	8	10	10	13	13	17	22
L	3,5	3,5	4,5	4,5	5,5	5,5	6,5	8,5	8,5	8,5
P	8	11	12	12	15	15	17	17	17	22
S	16	20	22	22	22	22	24	24	32	40
T	M6	M8	M10x1,25	M10x1,25	M10x1,25	M10x1,25	M12x1,25	M12x1,25	M16x1.5	M20x1.5
W	4,5	4,5	4,5	5,5	6	6,5	7,5	7,5	8	10
W+	4,5	4,5	4,5	5,5	6	6,5	7,5	7,5	8	10

+ = aggiungere lunghezza corsa (mm) - add stroke length (mm)

Ø	CORSE STANDARD - STANDARD STROKES
012	5 - 10 - 15 - 20 - 25 - 30 - 40 - 50 - 60 - 70 - 75 - 80 - 90 - 100 - 125 - 160 - 200 - 250
016	5 - 10 - 15 - 20 - 25 - 30 - 40 - 50 - 60 - 70 - 75 - 80 - 90 - 100 - 125 - 160 - 200 - 250
020	5 - 10 - 15 - 20 - 25 - 30 - 40 - 50 - 60 - 70 - 75 - 80 - 90 - 100 - 125 - 160 - 200 - 250
025	5 - 10 - 15 - 20 - 25 - 30 - 40 - 50 - 60 - 70 - 75 - 80 - 90 - 100 - 125 - 160 - 200 - 250
032	5 - 10 - 15 - 20 - 25 - 30 - 40 - 50 - 60 - 70 - 75 - 80 - 90 - 100 - 125 - 160 - 200 - 250 - 300 - 350 - 400
040	5 - 10 - 15 - 20 - 25 - 30 - 40 - 50 - 60 - 70 - 75 - 80 - 90 - 100 - 125 - 160 - 200 - 250 - 300 - 350 - 400
050	5 - 10 - 15 - 20 - 25 - 30 - 40 - 50 - 60 - 70 - 75 - 80 - 90 - 100 - 125 - 160 - 200 - 250 - 300 - 350 - 400
063	5 - 10 - 15 - 20 - 25 - 30 - 40 - 50 - 60 - 70 - 75 - 80 - 90 - 100 - 125 - 160 - 200 - 250 - 300 - 350 - 400
080	5 - 10 - 15 - 20 - 25 - 30 - 40 - 50 - 60 - 70 - 75 - 80 - 90 - 100 - 125 - 160 - 200 - 250 - 300 - 350 - 400
100	5 - 10 - 15 - 20 - 25 - 30 - 40 - 50 - 60 - 70 - 75 - 80 - 90 - 100 - 125 - 160 - 200 - 250 - 300 - 350 - 400

 SERIE
A

DOPPIO EFFETTO MAGNETICO STELO PASSANTE ANTIROTAZIONE

DOUBLE ACTING MAGNETIC ANTI-ROTATION WITH DOUBLE ROD

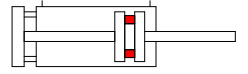

SERIE

A

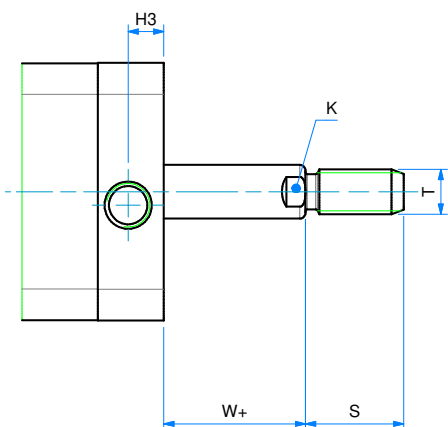
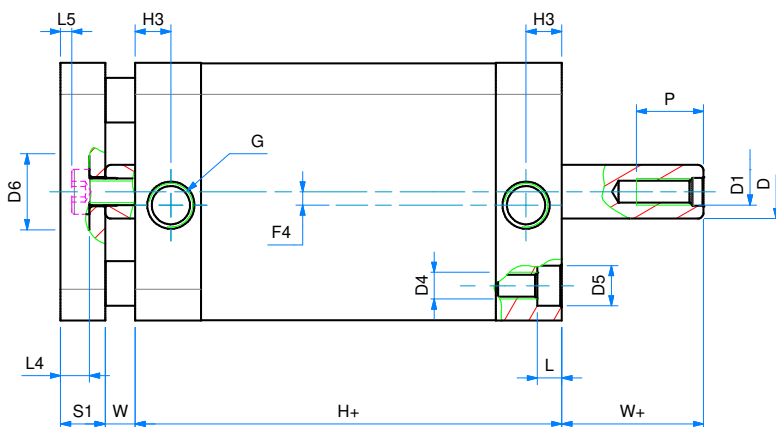
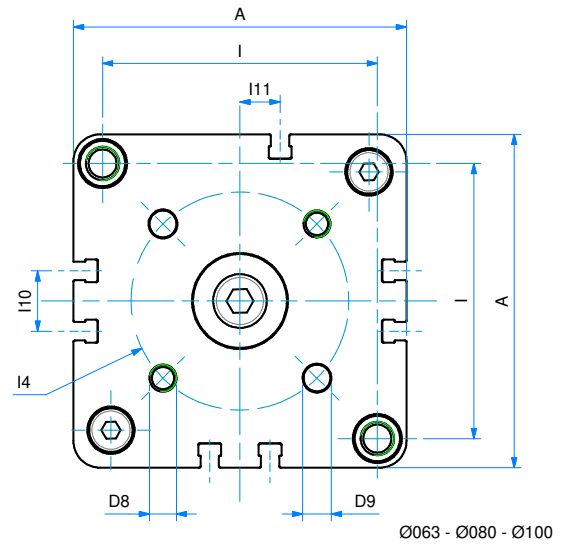
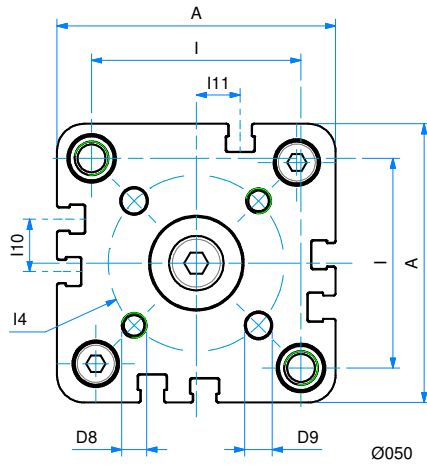
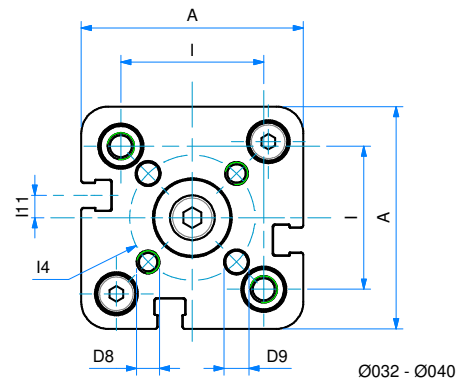
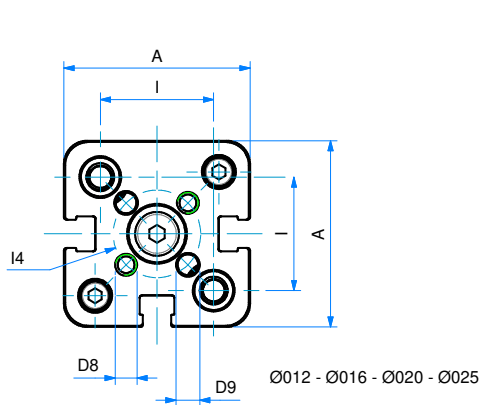

DOPPIO EFFETTO MAGNETICO STELO PASSANTE ANTIROTAZIONE
DOUBLE ACTING MAGNETIC ANTI-ROTATION WITH DOUBLE ROD

DIMENSIONI - DIMENSIONS									
Ø	016	020	025	032	040	050	063	080	100
A	29	36	40	50	58	67	80	100	124
Ø D	8	10	10	12	12	16	16	20	25
D1	M4	M5	M5	M6	M6	M8	M8	M10	M12
D4	M4	M5	M5	M6	M6	M8	M10	M10	M10
Ø D5	-	-	-	9	9	10,5	13,5	13,5	13,5
Ø D6	9	11	14	17	17	22	22	28	30
Ø D7	5	5	6	8	10	10	10	14	14
D8	M3	M4	M5	M5	M5	M6	M6	M8	M10
Ø D9	3	4	5	5	5	6	6	8	10
F4	-	-	-	4	3	-	-	-	-
G	M5	M5	M5	G1/8	G1/8	G1/8	G1/8	G1/8	G1/4
H+	38	38	39,5	44,5	45,5	45,5	50	56	66,5
H3	8	8	8	8	8	8	8	8,5	10,5
I	18	22	26	32	42	50	62	82	103
I4	14	17	22	28	33	42	50	65	80
I10	-	-	-	-	-	12,5	14	18	35
I11	-	-	-	5	3	10,5	12	12	17,5
K	6	8	8	10	10	13	13	17	22
L	-	-	-	5,5	5,5	6,5	8,5	8,5	8,5
S	20	22	22	22	22	24	24	32	40
T	M8	M10x1,25	M10x1,25	M10x1,25	M10x1,25	M12x1,25	M12x1,25	M16x1,5	M20x1,5
P	11	12	12	15	15	17	17	17	22
W	4,5	4,5	5,5	6	6,5	7,5	7,5	8	10
W+	4,5	4,5	5,5	6	6,5	7,5	7,5	8	10
S1	6	8	8	10	10	12	12	14	14

+ = aggiungere lunghezza corsa (mm) - add stroke length (mm)

Ø	CORSE STANDARD - STANDARD STROKES
016	5 - 10 - 15 - 20 - 25 - 30 - 40 - 50 - 60 - 70 - 75 - 80 - 90 - 100 - 125 - 160 - 200
020	5 - 10 - 15 - 20 - 25 - 30 - 40 - 50 - 60 - 70 - 75 - 80 - 90 - 100 - 125 - 160 - 200
025	5 - 10 - 15 - 20 - 25 - 30 - 40 - 50 - 60 - 70 - 75 - 80 - 90 - 100 - 125 - 160 - 200
032	5 - 10 - 15 - 20 - 25 - 30 - 40 - 50 - 60 - 70 - 75 - 80 - 90 - 100 - 125 - 160 - 200 - 250 - 300 - 350 - 400
040	5 - 10 - 15 - 20 - 25 - 30 - 40 - 50 - 60 - 70 - 75 - 80 - 90 - 100 - 125 - 160 - 200 - 250 - 300 - 350 - 400
050	5 - 10 - 15 - 20 - 25 - 30 - 40 - 50 - 60 - 70 - 75 - 80 - 90 - 100 - 125 - 160 - 200 - 250 - 300 - 350 - 400
063	5 - 10 - 15 - 20 - 25 - 30 - 40 - 50 - 60 - 70 - 75 - 80 - 90 - 100 - 125 - 160 - 200 - 250 - 300 - 350 - 400
080	5 - 10 - 15 - 20 - 25 - 30 - 40 - 50 - 60 - 70 - 75 - 80 - 90 - 100 - 125 - 160 - 200 - 250 - 300 - 350 - 400
100	5 - 10 - 15 - 20 - 25 - 30 - 40 - 50 - 60 - 70 - 75 - 80 - 90 - 100 - 125 - 160 - 200 - 250 - 300 - 350 - 400

ACCESSORI DI FISSAGGIO UNITOP

UNITOP MOUNTING PARTS

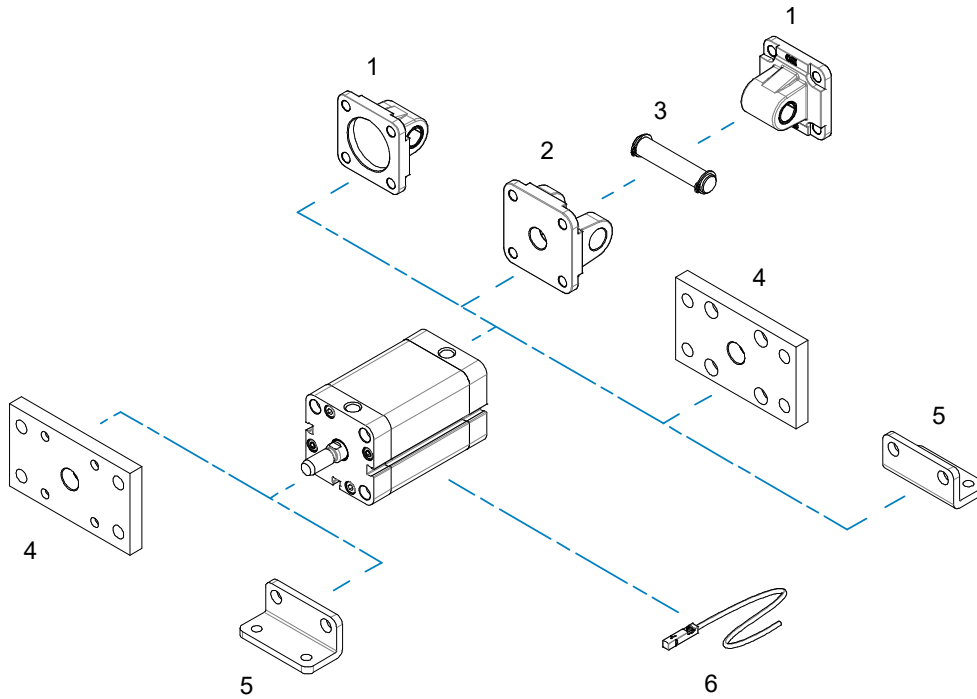

SERIE

A

POS.	CODE	DESCRIZIONE - DESCRIPTION
1	CMI---	cerniera maschio - male hinge
2	CFU---	cerniera femmina unitop - unitop female hinge
3	PCF---	perno per cerniera - pin for hinge
4	FU---	flangia unitop - unitop flange
5	PBU---	pedino basso unitop - unitop foot mounting
6	36.SEN---	sensore magnetico - magnetic sensor

Fissaggi forniti con viti - Mounting parts supplied with screws

CERNIERA MASCHIO

MALE HINGE

CMI

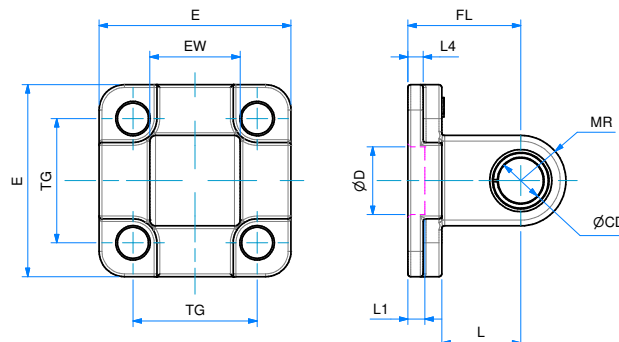

DIMENSIONI - DIMENSIONS

COD.	CMI016	CMI020	CMI025
Ø	16	20	25
E	27	34	38
EW	12	16	16
TG	18	22	26
FL	16	20	20
L1	/	3	3
L	10	14	14
L4	3,4	2,7	2,7
ØD	/	12	12
ØCD	6	8	8
MR	6	8	8

CERNIERA FEMMINA UNITOP

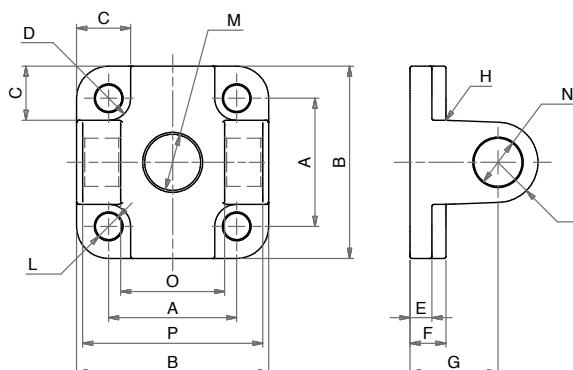

LA FORNITURA COMPRENDE:
n° 1 CERNIERA FEMMINA
n° 4 VITI
THE SUPPLY INCLUDES:
n° 1 FEMALE HINGE
n° 4 SCREWS

MATERIALE: ALLUMINIO
MATERIAL: ALUMINIUM

SERIE

A

DIMENSIONI - DIMENSIONS

COD.	CFU032	CFU040	CFU050	CFU063	CFU080	CFU100
ø	32	40	50	63	80	100
A	32	42	50	62	82	103
B	48	58	66	83	102	123
C	13,5	13,5	15,5	18	19	19
D	5,5	5,5	7,5	7,5	9	9
E	5,5	5,5	6,5	6,5	10	10
F	9	9	11	11	13	15
G	22	25	27	32	36	41
H	2,5	2,5	2,5	4	4	4
I	10	12,5	12,5	15	15	20
L	6,6	6,6	9	9	11	11
M	14	14	18	18	23	28
N	12	14	14	18	18	23
O	26	28	32	40	50	60
P	45	52	60	70	90	110
Q	10	12	12	16	16	20

PERNO PER CERNIERA (AA4)

PCF

PIN FOR HINGE (AA4)

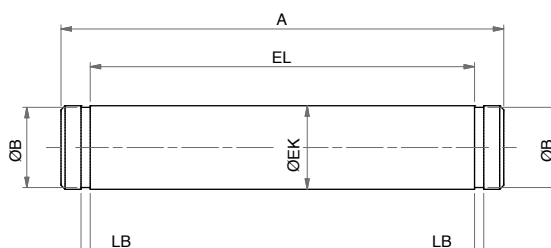

LA FORNITURA COMPRENDE:
n° 1 PERNO
n° 2 SEEGER
THE SUPPLY INCLUDES:
n° 1 PIN
n° 2 RETAINING RING

MATERIALE:
ACCIAIO ZINCATO
MATERIAL:
ZINC COATED STEEL

DIMENSIONI - DIMENSIONS

COD.	PCF032	PCF040	PCF050	PCF063	PCF080	PCF100	PCF125	PCF160.200
ø	32	40	50	63	80	100	125	160-200
A	53	60	68	78	98	118	139	180
EL	46	53	61	71	91	111	132	172
LB	1,1	1,1	1,1	1,1	1,1	1,3	1,3	1,6
ø B	9,6	11,5	11,5	15,2	15,2	19	23,9	28,6
ø EK	10	12	12	16	16	20	25	30

FLANGIA UNITOP
UNITOP MOUNTING

SERIE

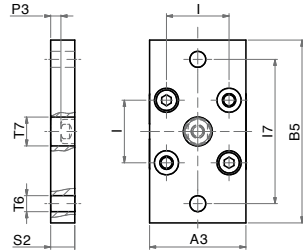
A

LA FORNITURA
COMPRENDE:
n° 1 FLANGIA
n° 2 VITI
THE SUPPLY INCLU-
DES:
n° 1 FLANGE
n° 2 SCREWS

Ø016 - Ø020 - Ø025

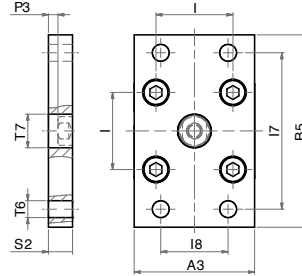

LA FORNITURA COM-
PRENDE: n° 1 FLANGIA
n° 4 VITI
THE SUPPLY INCLUDES:
n° 1 FLANGE
n° 4 SCREWS

MATERIALE:
ACCIAIO ZINCATO
MATERIAL:
ZINC COATED STEEL

Ø032 - Ø040 - Ø050 - Ø063 - Ø080 - Ø100

DIMENSIONI - DIMENSIONS

COD.	FI016	FI020	FI025	FU032	FU040	FU050	FU063	FU080	FU100
Ø	016	020	025	032	040	050	063	080	100
A3	29	36	40	50	60	68	87	107	128
B5	55	70	76	80	102	110	130	160	190
I7	43	55	60	65	82	90	110	135	163
I8	-	-	-	32	36	45	50	63	75
I	18	22	26	32	42	50	62	82	103
Ø T6	5,5	6,5	6,5	7	9	9	9	12	14
Ø T7	10	12	12	14	14	18	18	23	28
P3	5,5	5,5	4,5	4	3,5	4,5	7,5	7	5
S2	10	10	10	10	10	12	15	15	15

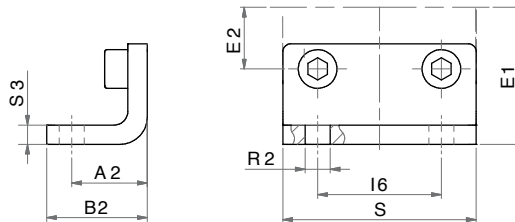
PIEDINO BASSO UNITOP
UNITOP FOOT MOUNTING
PBU

LA FORNITURA
COMPRENDE:
n° 1 PIEDINI
n° 2 VITI
THE SUPPLY INCLUDES:
n° 1 FOOT MOUNTING
n° 2 SCREWS

MATERIALE:
ACCIAIO ZINCATO
MATERIAL:
ZINC COATED STEEL

DIMENSIONI - DIMENSIONS

COD.	PBI016	PBI020	PBI025	PBU032	PBU040	PBU050	PBU063	PBU080	PBU100
Ø	016	020	025	032	040	050	063	080	100
A2	13	16	16	18	20	24	27	30	33
B2	17,5	22	22	26	28	32	39	42	45
E1	22	27	30	32	42,5	47	59,5	62,5	78
E2	9	11	13	16	21	25	31	41	51,5
I6	18	22	26	32	42	50	62	82	103
Ø R2	5,5	6,5	6,5	6,5	9	9	11	11	13,5
S	30	36	40	50	60	68	84	102	123
S3	3	4	4	5	5	6	6	8	8

SENSORI MAGNETICI

MAGNETIC SENSORS

CARATTERISTICHE - CHARACTERISTICS				
CODICE - CODE	36.SEN06 36.SEN06.L6	36.SEN07	36.SEN08	36.SEN09 36.SEN09.L6 36.SEN09.L10
TIPO - TYPE	REED	REED	ELETTRONICO ELECTRONIC	ELETTRONICO ELECTRONIC
Modello elettrico - Electrical design	AC/DC PNP/NPN	AC/DC PNP/NPN	DC PNP	DC PNP
Funzione dell'uscita - Output	NO	NO	NO	NO
Tensione di esercizio - Operating voltage	[V] 5...120 AC/DC	5...60 DC / 5...50 AC	10...30 DC	10...30 DC
Capacità di corrente - Current rating	[mA] 100*	100*	100	100
Sensibilità di reazione - Magnetic sensitivity	[mT] 2,1	2,1	2,8	2,8
Velocità di passaggio - Travel speed	[m/s] > 10	> 10	> 10	> 10
Protezione da cortocircuito - Short-circuit proof	no	no	si - yes	si - yes
Protetto da inversione di polarità Reverse polarity protection	si - yes	si - yes	si - yes	si - yes
Resistente a sovraccarico - Overload protection	no	no	si - yes	si - yes
Caduta di tensione - Voltage drop	[V] < 5	< 5	< 2,5	< 2,5
Isteresi - Hysteresis	1	1	< 1,5	< 1,5
Riproducibilità - Repeatability	[mm] ± 0,2	± 0,2	< 0,2	< 0,2
Corrente assorbita - Current consumption	[mA] -	-	< 10	< 10
Tempo di commutazione - Make time	[ms] ≤ 0,6	≤ 0,6	-	-
Tempo di riapertura - Fall time	[ms] ≤ 0,1	≤ 0,1	-	-
Potenza max - Switching power max	[W] 10	10	-	-
Cicli di commutazione con connessione a PLC Switching cycles when connected to PLC	[mln] ≤ 40	≤ 40	-	-
Frequenza di commutazione - Switching frequency	[Hz] 1.000	1.000	> 10.000	> 10.000
Temperatura ambiente - Ambient temperature	[°C] -25...70	-25...70	-25...80	-25...80
Grado/Classe di protezione - Protection	IP67, II	IP67, II	IP67, III	IP67, III
Materiale involucri - Housing material	PA (poliammide - polyamide)			
Materiale eccentrico di fissaggio - Fastening clamp	inox - stainless steel			
Indicazione della funzione Stato di commutazione Function display Switching status	LED	giallo - yellow		
Collegamento - Connection	cavo PUR - PUR cable 2x0,14 mm ² 2 m (.L6 = 6 m)	cavo PUR - PUR cable connettore M8- M8 connector 0,3 m	cavo PUR - PUR cable connettore M8- M8 connector 0,3 m	cavo PUR - PUR cable 3x0,14 mm ² 2 m (.L6 = 6 m .L10 = 10 m)
Peso - Weight	[g] 31,3 69	12	12,1	27,4 73,5 122,4

SERIE

A

Accessori inclusi: Segnaposto in gomma, fascetta fermacavo - Accessories included: Rubber placeholder, cable clip

*: necessario circuito di protezione esterno per carico induttivo (valvola, relè, ecc...). - External protective circuit for inductive load (valve, contactor, etc...) necessary.

REED: nessuna funzione LED in caso di inversione di polarità nel funzionamento DC. - No LED function in case of polarity reversal in DC operation.

CONTATTO REED (2 FILI)

36.SEN06

36.SEN06.L6

REED CONTACT (2 WIRES)

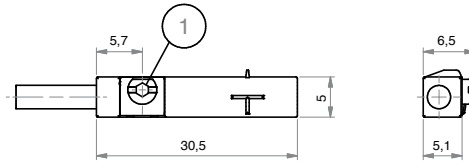

1= ECCENTRICO DI FISSAGGIO - FASTENING CLAMP

CABLAGGIO - WIRING

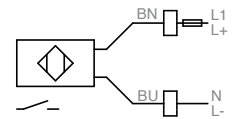

BN= MARRONE - BROWN
BU= BLU - BLUE

SERIE

A

CONTATTO REED (CONNETTORE M8)

36.SEN07

REED CONTACT (M8 CONNECTOR)

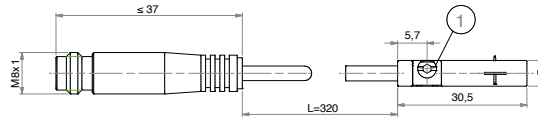

1= ECCENTRICO DI FISSAGGIO - FASTENING CLAMP

CABLAGGIO - WIRING

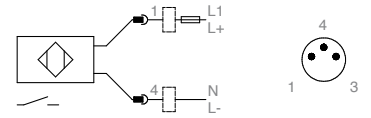

BN= MARRONE - BROWN
BU= BLU - BLUE

CONTATTO PNP (CONNETTORE M8)

36.SEN08

PNP CONTACT (M8 CONNECTOR)

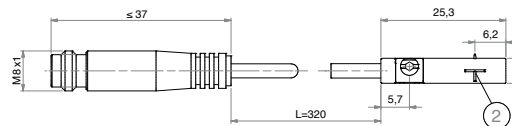

1= ECCENTRICO DI FISSAGGIO FASTENING CLAMP
2= SUPERFICIE ATTIVA SENSING FACE

CABLAGGIO - WIRING

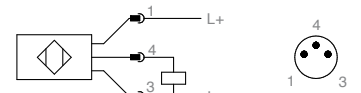

BN= MARRONE - BROWN
BU= BLU - BLUE

CONTATTO PNP (3 FILI)

36.SEN09

36.SEN09.L6

36.SEN09.L10

PNP CONTACT (3 WIRES)

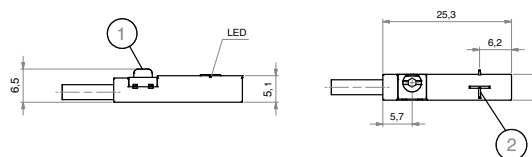

1= ECCENTRICO DI FISSAGGIO - FASTENING CLAMP
2= SUPERFICIE ATTIVA - SENSING FACE

CABLAGGIO - WIRING

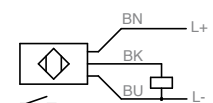

BK= NERO - BLACK
BN= MARRONE - BROWN
BU= BLU - BLUE

CAVO PROLUNGA (CONNETTORE M8)

36.CAV

EXTENSION CABLE (M8 CONNECTOR)

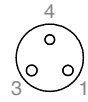
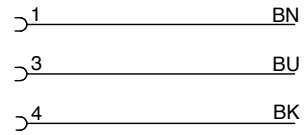
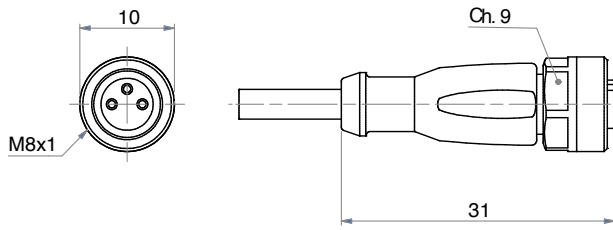

SERIE

A



SENSORI MAGNETICI ATEX

ATEX MAGNETIC SENSORS

CARATTERISTICHE - CHARACTERISTICS		36.SEN32A.L6	36.SEN33A
TIPO - TYPE		ELETTRONICO - ELECTRONIC	ELETTRONICO - ELECTRONIC
Modello elettrico - Electrical design		DC PNP	DC PNP
Funzione dell'uscita - Output		NO	NO
Tensione di esercizio - Operating voltage	[V]	10...30 DC	10...30 DC
Capacità di corrente - Current rating	[mA]	100	100
Sensibilità di reazione - Magnetic sensitivity	[mT]	2	2,8
Velocità di passaggio - Travel speed	[m/s]	> 10	> 10
Protezione da cortocircuito - Short-circuit proof		si - yes	si - yes
Protetto da inversione di polarità - Reverse polarity protection		si - yes	si - yes
Resistente a sovraccarico - Overload protection		si - yes	si - yes
Caduta di tensione - Voltage drop	[V]	< 2,5	< 2,5
Isteresi - Hysteresis		1	< 1,5
Riproducibilità - Repeatability	[mm]	< 0,2	< 0,2
Corrente assorbita - Current consumption	[mA]	< 10	< 10
Ritardo alla disponibilità - Power-on delay time	[ms]	< 30	< 30
Frequenza di commutazione - Switching frequency	[Hz]	6.000	10.000
Temperatura ambiente - Ambient temperature	[°C]	-20...60	-25...60
Grado/Classe di protezione - Protection		IP 65/IP 67	IP 65/IP 67
Contrassegno - Marking of the unit		II 3D Ex tc IIIC T125°C Dc X II 3G Ex nA IIC T4 Gc X	II 3D Ex tc IIIC T125°C Dc X
Materiale involucro - Housing material		PA (poliammide-polyamide)	PA (poliammide-polyamide)
Materiale eccentrico di fissaggio - Fastening clamp		inox - stainless steel	inox - stainless steel
Indicazione della funzione Stato di commutazione Function display Switching status	LED	giallo - yellow	giallo - yellow
Collegamento - Connection		cavo PVC - PVC cable 3x0,14 mm ²	cavo PVC - PVC cable connettore M12 - M12 connector
Lunghezza cavo - Cable length		6 m	0,3 m
Peso - Weight		[g] 103,3	52,4

Accessori inclusi - Accessories included: Segnaposto in gomma, fascetta fermacavo - Rubber placeholder, cable clip

SERIE

A



36.SEN32A.L6

CONTATTO PNP (3 FILI)

PNP CONTACT (3 WIRES)



1= ECCENTRICO DI FISSAGGIO - FASTENING CLAMP
2= SUPERFICIE ATTIVA - SENSING FACE

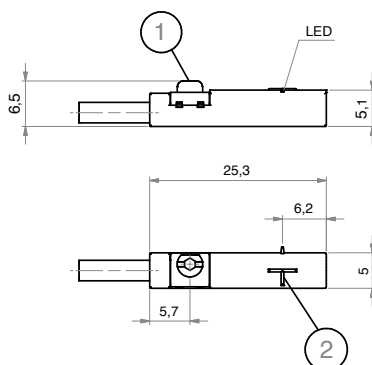

CABLAGGIO - WIRING

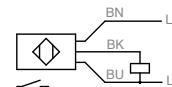

BK= NERO - BLACK
BN= MARRONE - BROWN
BU= BLU - BLUE

SERIE
A



36.SEN33A

CONTATTO PNP (CONNETTORE M12)

PNP CONTACT (M12 CONNECTOR)



1= ECCENTRICO DI FISSAGGIO - FASTENING CLAMP
2= SUPERFICIE ATTIVA - SENSING FACE

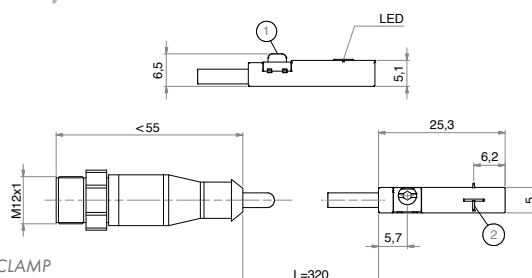

CABLAGGIO - WIRING



BK= NERO - BLACK
BN= MARRONE - BROWN
BU= BLU - BLUE



36.CAVA

CAVO PROLUNGA (CONNETTORE M12)

EXTENSION CABLE (M12 CONNECTOR)

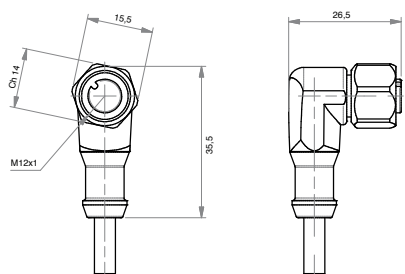

CABLAGGIO - WIRING

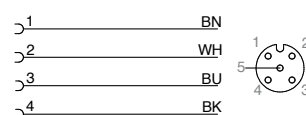

BK= NERO - BLACK
BN= MARRONE - BROWN

BU= BLU - BLUE
WH= BIANCO - WHITE

DIMENSIONI - DIMENSIONS	36.CAV5A.M12	36.CAV10A.M12
Modello elettrico - Electrical design	AC/DC	AC/DC
Tensione di esercizio - Operating voltage	[V] 60 AC / 60 DC	60 AC / 60 DC
Capacità di corrente - Current rating	[A] 2	2
Modello - Design	ad angolo - angled	ad angolo - angled
Temperatura ambiente - Ambient temperature	[°C] -20...60	-20...60
Grado/Classe di protezione - Protection	IP67/IP68 - IP69K fuori dalla zona esplosiva - outside hazardous areas	
Contrassegno - Marking of the unit	II 3G Ex nA IIC Gc - II 2D Ex tb IIIC Db IP65/IP67	
Materiale corpo - Body material: Involucro - Housing	TPU arancione - orange TPU	TPU arancione - orange TPU
Guarnizione - Sealing	viton	viton
Materiale dado - Nut material	inox - stainless steel (1.4404 / 316L)	inox - stainless steel (1.4404 / 316L)
Coppia di serraggio per nodo nocciolo Tightening torque for knurled nut	[Nm] 0,2...1,5	0,2...1,5
Collegamento - Connection	cavo PUR - PUR cable / 5 m; 4 x 0,34 mm ² (42 x Ø 0,1 mm); Ø 4,9 mm; senza alogeno - alogen free	cavo PUR - PUR cable / 10 m; 4 x 0,34 mm ² (42 x Ø 0,1 mm); Ø 4,9 mm; senza alogeno - alogen free
Colore della guaina - Sheath colour	nero - black	nero - black

AIR

THE BEST WAY TO



ARTEC SRL Via B. Zallone, 24

44042 CENTO (FE) - ITALY

☎ +39 051 683 62 20

☎ +39 051 683 08 82

✉ info@artec-pneumatic.com

🌐 www.artec-pneumatic.com



AZIENDA CON SISTEMA
DI GESTIONE QUALITÀ
CERTIFICATO ISO 9001:2015

PARTNER IN THE U.S.A & CANADA



W.C. Branham, Inc.

398 Troy Street

River Falls, WI 54022

☎ 800-428-1974 (Toll-free US & Canada)

715-426-2000 (Main)

☎ 715-426-1400

✉ AskWCB@wcbranham.com

🌐 www.wcbranham.com