

SERIE

**E**

**CILINDRO COMPATTO GUIDATO**  
**GUIDED COMPACT CYLINDER**

  
**ARTEC**<sup>®</sup>  
PNEUMATIC COMPONENTS

 **WC  
BRANHAM**<sup>®</sup>  
SOLUTIONS IN MOTION

### CARATTERISTICHE TECNICHE - TECHNICAL CHARACTERISTICS

<b>Pressione di esercizio</b> <i>Working pressure</i>	1 ÷ 10 bar (doppio effetto - <i>double acting</i> )
<b>Temperatura di esercizio</b> <i>Working temperature</i>	0 ÷ +80°C (-20°C con aria secca - <i>with dry air</i> )
<b>Versioni - Versions</b>	doppio effetto - <i>double acting</i>
<b>Alesaggi - Bores</b>	∅ 16 - 20 - 25 - 32 - 40 - 50 - 63
<b>Corse - Strokes</b>	vedere tabelle corse standard - <i>see standard stroke tables</i>
<b>Fluido - Fluid</b>	aria compressa filtrata, non lubrificata - <i>compressed filtered, non lubricated air</i>

### CARATTERISTICHE COSTRUTTIVE - CONSTRUCTIVE CHARACTERISTICS

① <b>Piastra - Plate</b>	acciaio nichelato - <i>nickel steel</i>
② <b>Stelo di Guida - Guide Rod</b>	acciaio C45 cromato - <i>C45 chromed steel</i>
③ <b>Raschiatore - Wiper</b>	NBR
④ <b>Boccola - Bush</b>	bronzo sinterizzato - <i>sintered bronze</i>
⑤ <b>Corpo - Body</b>	alluminio anodizzato - <i>anodized aluminum</i>
⑥ <b>Guarnizione stelo - Rod Seal</b>	poliuretano - <i>polyurethane</i>
⑦ <b>Testa Anteriore - Front Cover</b>	alluminio anodizzato - <i>anodized aluminum</i>
⑧ <b>Paracolpo - Bumper</b>	NBR
⑨ <b>Stelo - Rod</b>	acciaio C45 cromato - <i>C45 chromed steel</i>
⑩ <b>Pistone - Piston</b>	alluminio - <i>aluminum</i>
⑪ <b>Guarnizione Pistone - Piston Seal</b>	NBR
⑫ <b>Magnete - Magnet</b>	plastroferrite
⑬ <b>Testa posteriore - Rear Cover</b>	alluminio anodizzato - <i>anodized aluminum</i>

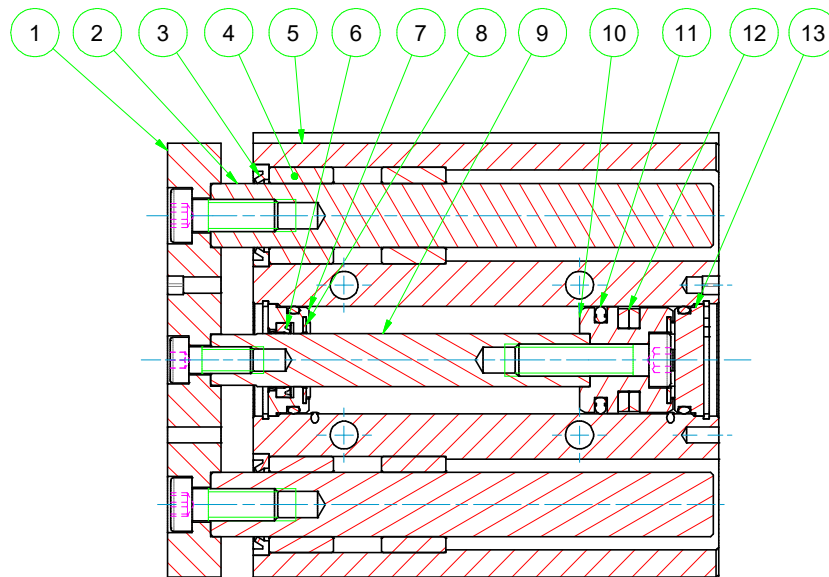

## CHIAVE DI CODIFICA

### KEY CODE

E D M			0 5 0 . 0 3 0 . G S					
			<b>ALESAGGIO - BORE (Ø)</b>		<b>CORSA - STROKE (mm)</b>		<b>OPZIONE - OPTION</b>	
			016 - 020 - 025 - 032 040 - 050 - 063		vedere tabelle corse std see std stroke table		EX ATEX  II 2GD c T4	
			<b>VERSIONE - VERSION</b>				<b>OPZIONE - OPTION</b>	
			con boccole in bronzo with bronze bushes				.S steli-viti-seeger inox SS rod screws-retaining ring	
			S con cuscinetti a ricircolo di sfere with recirculating ball bearings				<b>OPZIONE - OPTION</b>	
			<b>VERSIONE - VERSION</b>				senza ammortizzo pneumatico without pneumatic cushioning	
			M magnetico magnetic				.W con ammortizzo pneumatico with pneumatic cushioning	
			non magnetico non-magnetic					
			<b>VERSIONE - VERSION</b>				<b>GUARNIZIONI - SEALS</b>	
			D doppio effetto double acting				GS guarnizioni standard standard seals	
							VR guarnizione stelo per alte temperature high temperature rod seal	
							VA tutte le guarnizioni per alte temperature all seals for high temperature	
			<b>SERIE - SERIES</b>					
			E tubo profilato con cave per sensori profile tube with slots for sensors					

SERIE

E

### ESECUZIONI A RICHIESTA - ON REQUEST

Doppia piastra - Double plate

Stelo prolungato (FB) - Extended rod (FB)

ATEX II 2GD c T4

### FORZE TEORICHE DI TRAZIONE (P=6bar)

#### THEORETICAL FORCES OF TRACTION (P=6bar)

		Ø	016	020	025	032	040	050	063
EDM	SPINTA THRUST	[N]	121	188	295	483	754	1178	1870
	TRAZIONE TRACTION	[N]	90	141	247	415	686	1057	1750

### ESEMPI DI FISSAGGIO

#### FIXING EXAMPLE

MONTAGGIO SUPERIORE  
TOP MOUNTING

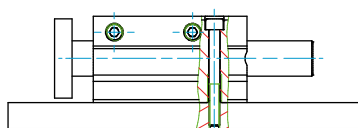

MONTAGGIO INFERIORE  
BOTTOM MOUNTING

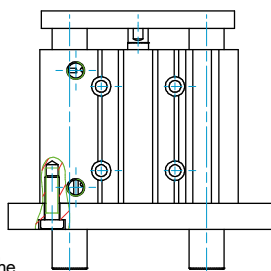

MONTAGGIO LATERALE  
SIDE MOUNTING

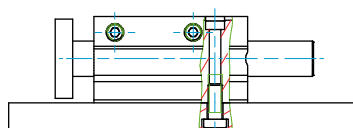

MONTAGGIO TRAMITE  
DADO NELLA CAVA A "T"  
NUT INSIDE T-SLOT  
MOUNTING

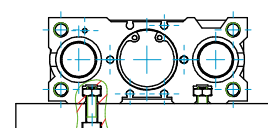

!!! Il fissaggio deve avvenire mediante viti amagnetiche  
!!! The fixing must be with non-magnetic screws

**DIAGRAMMA TEORICO CARICO AMMISSIBILE**

**THEORETICAL ALLOWABLE LOAD**

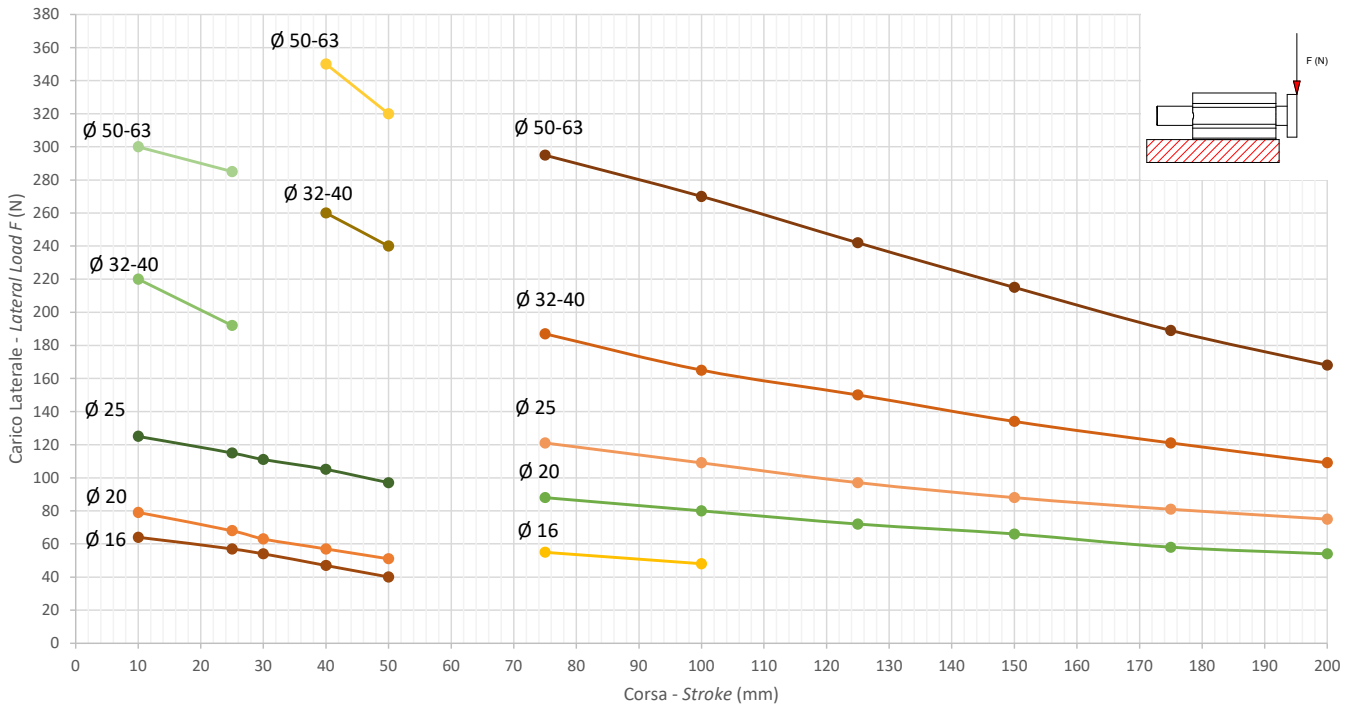

SERIE  
**E**

**DIAGRAMMA TEORICO CARICO AMMISSIBILE**

**THEORETICAL ALLOWABLE LOAD**

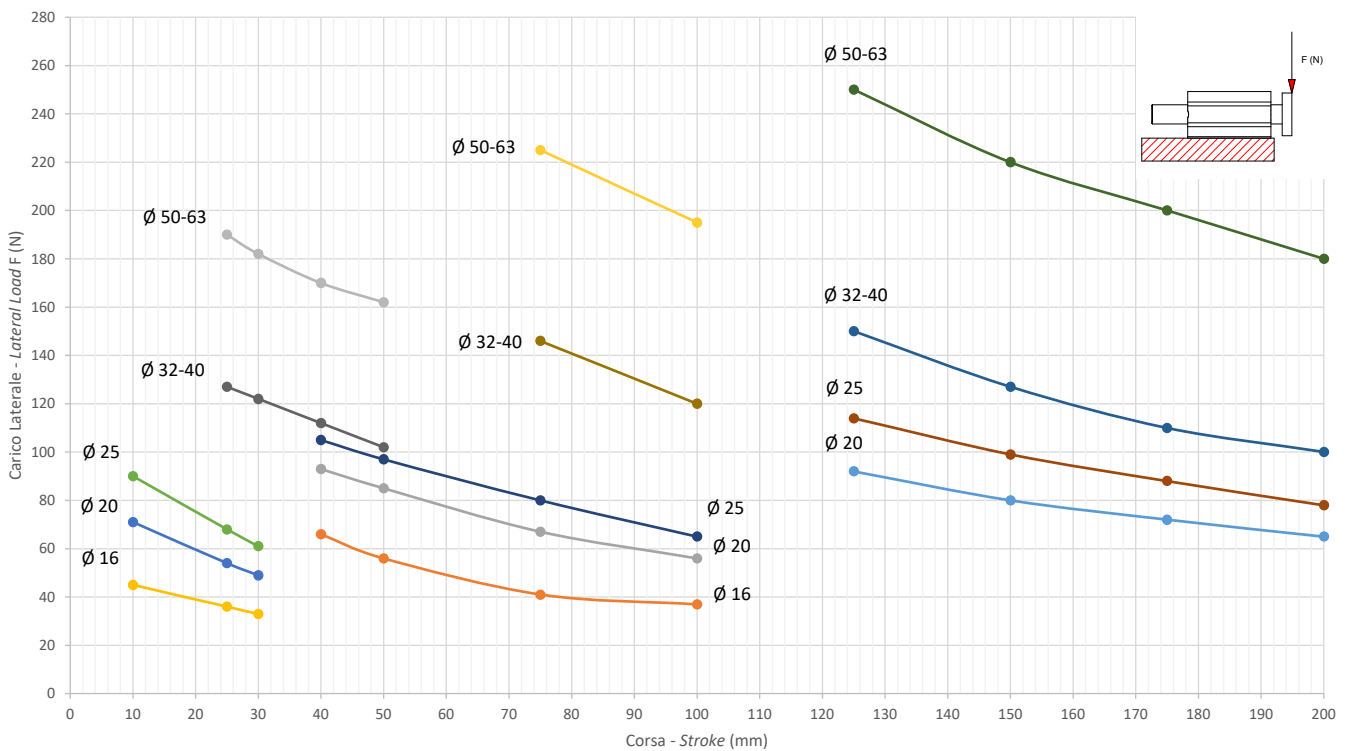

**DIAGRAMMA TEORICO CARICO AMMISSIBILE**

**THEORETICAL ALLOWABLE LOAD**

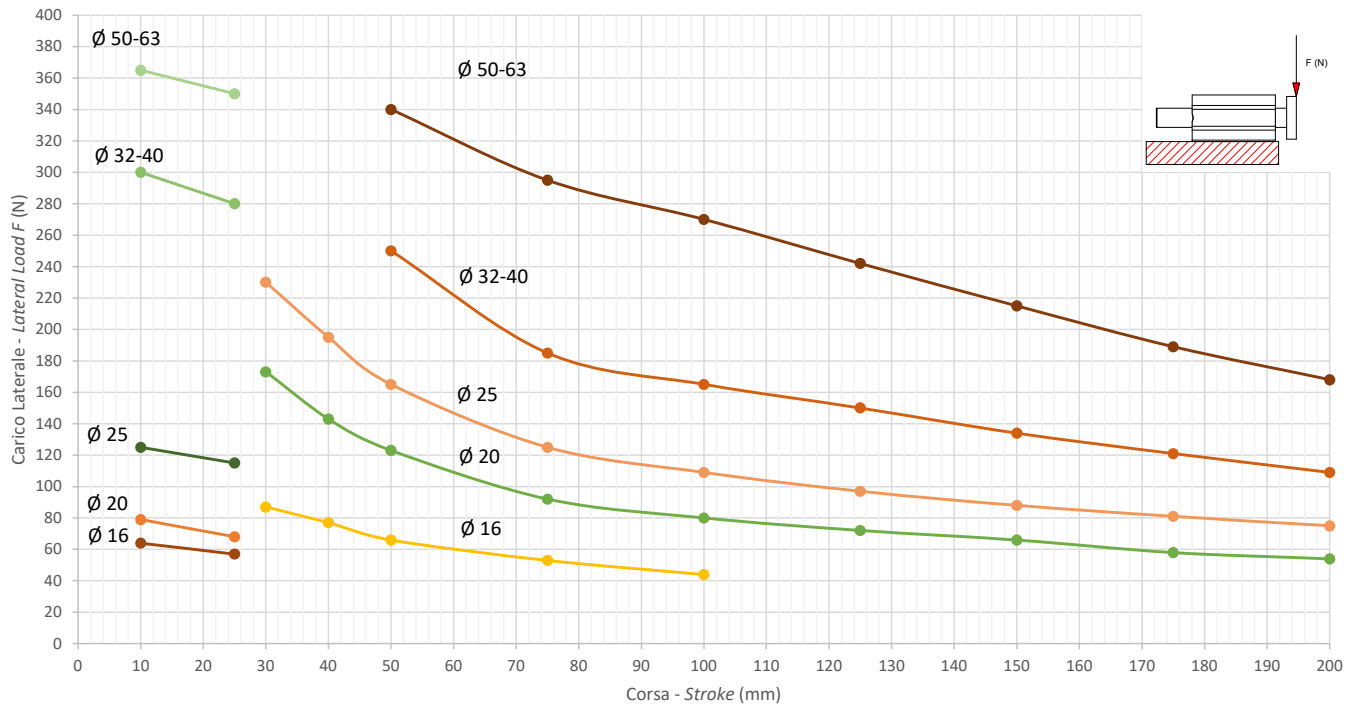

SERIE  
**E**

**DIAGRAMMA TEORICO CARICO AMMISSIBILE**

**THEORETICAL ALLOWABLE LOAD**

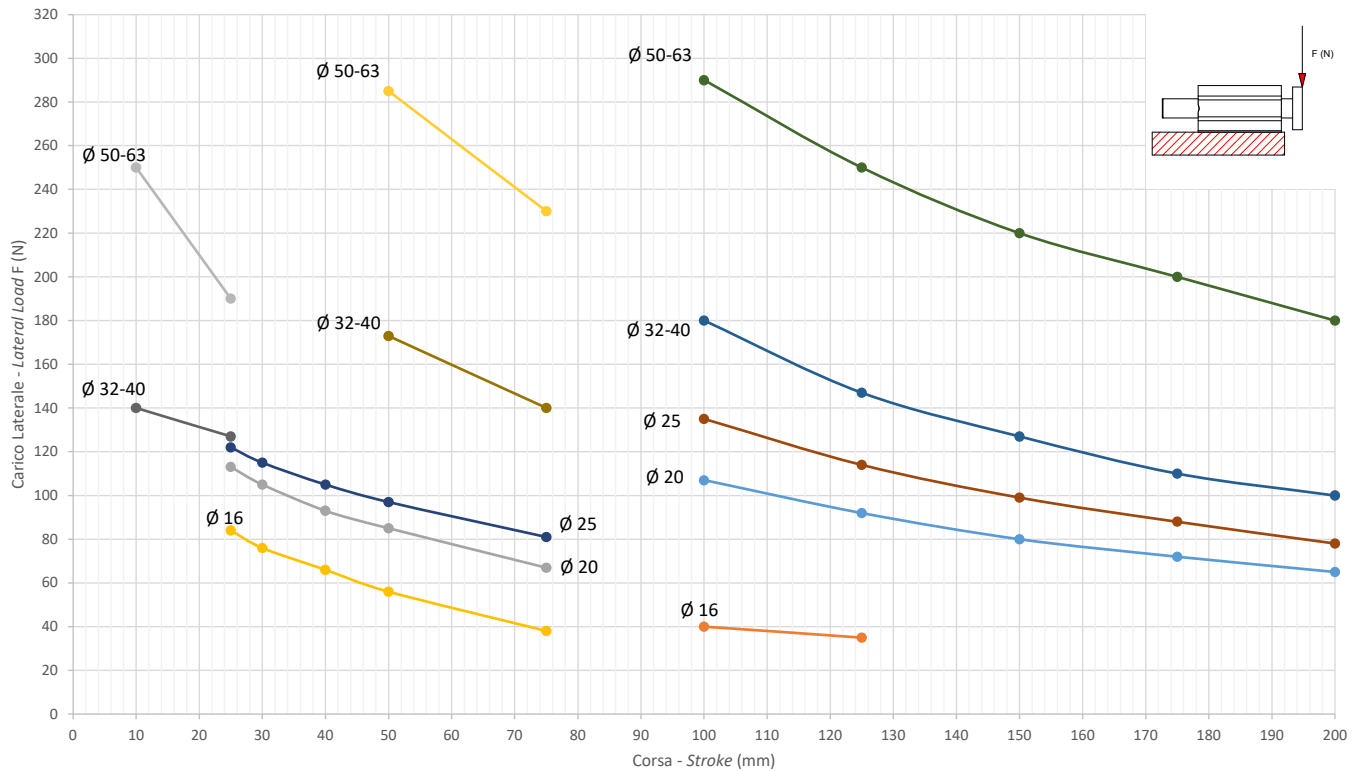

**DIAGRAMMA TEORICO COPPIA AMMISSIBILE**

**THEORETICAL ALLOWABLE TORQUE**

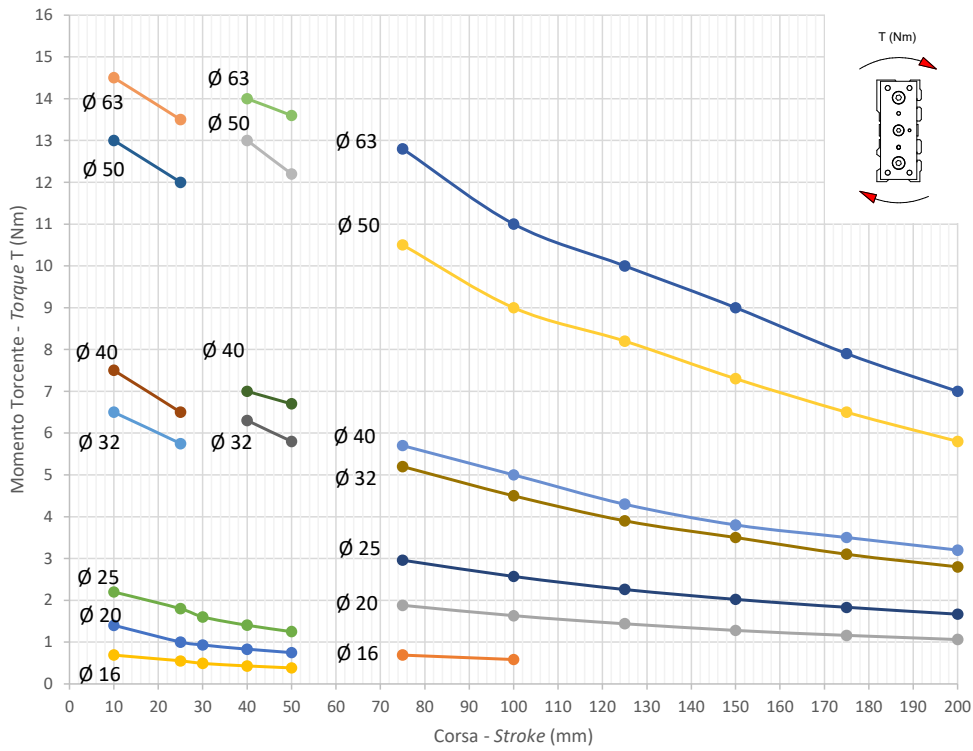

SERIE

**E**

**DIAGRAMMA TEORICO COPPIA AMMISSIBILE**

**THEORETICAL ALLOWABLE TORQUE**

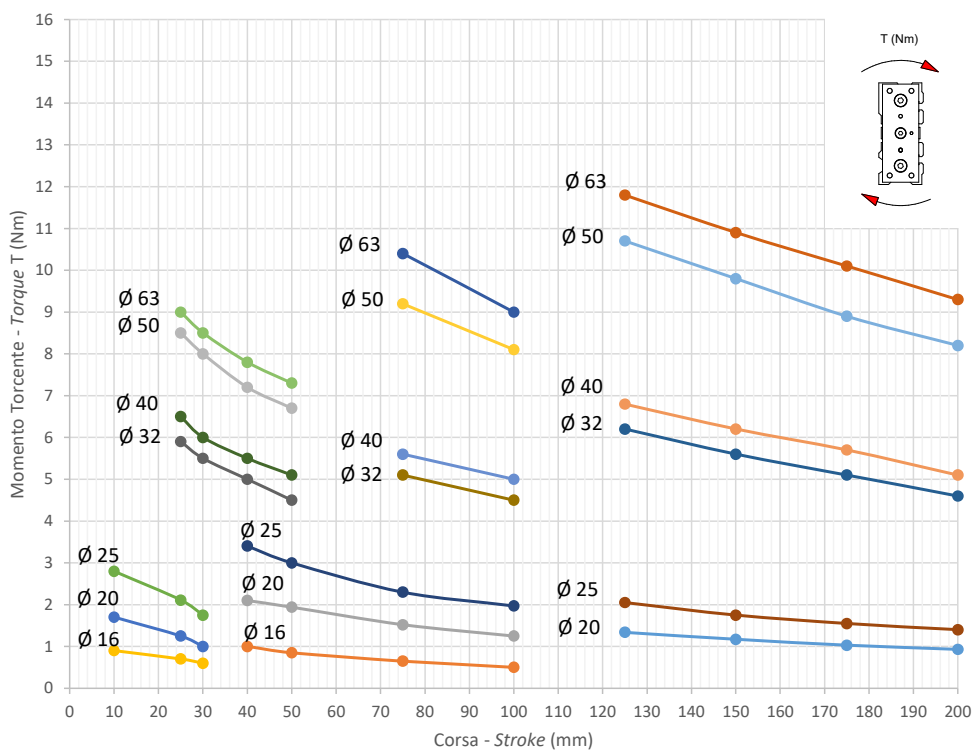

**DIAGRAMMA TEORICO COPPIA AMMISSIBILE**

**THEORETICAL ALLOWABLE TORQUE**

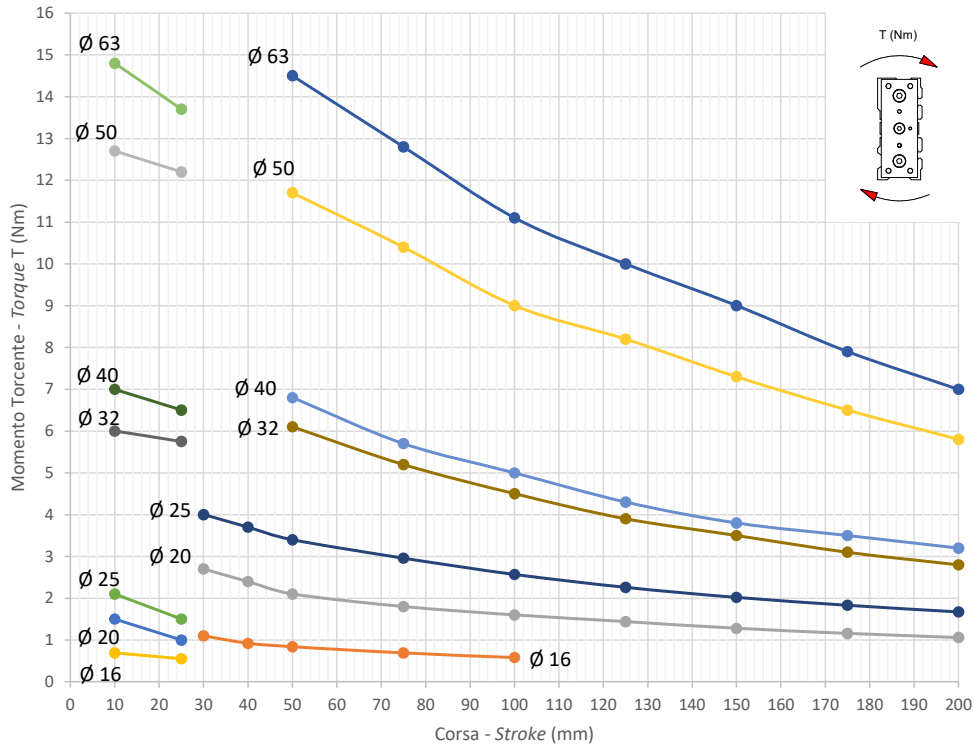

**DIAGRAMMA TEORICO COPPIA AMMISSIBILE**

**THEORETICAL ALLOWABLE TORQUE**

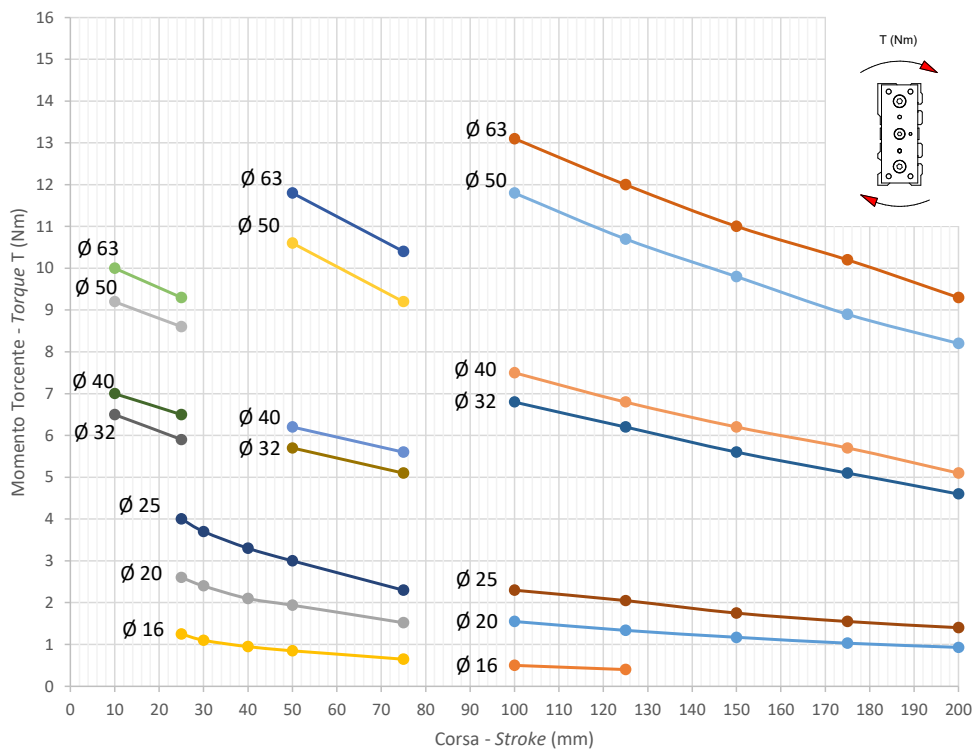

**COMPATTO GUIDATO D.E.M.**

**D.A.M. GUIDED COMPACT**

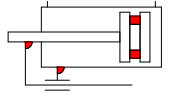

**CAVA SENSORE A C**  
**C-SLOT FOR SENSOR**



SERIE  
**E**

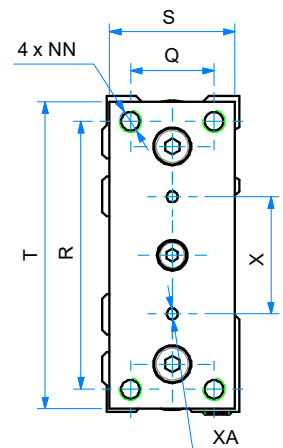
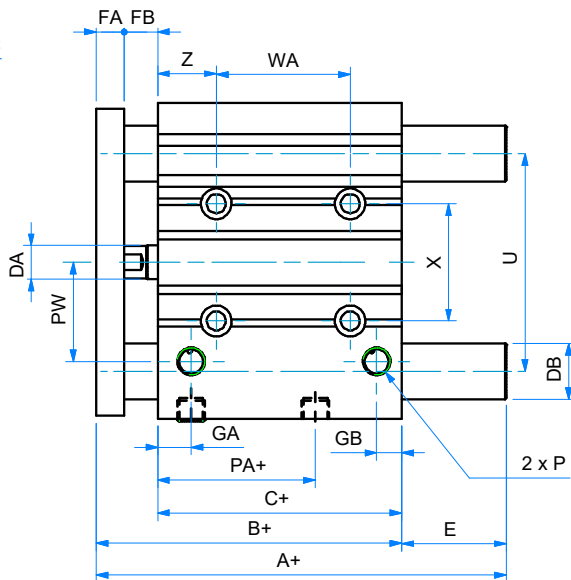
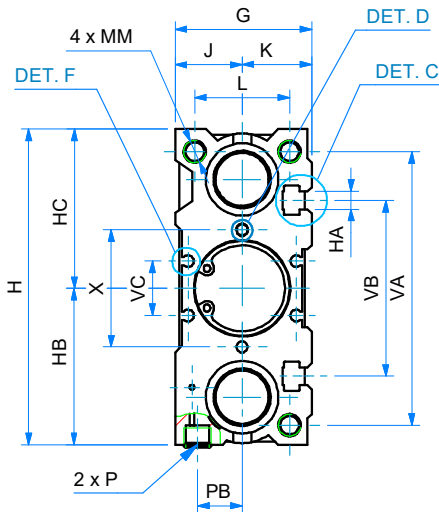
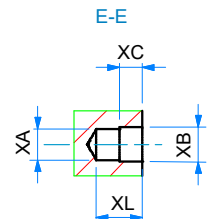
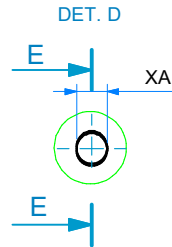
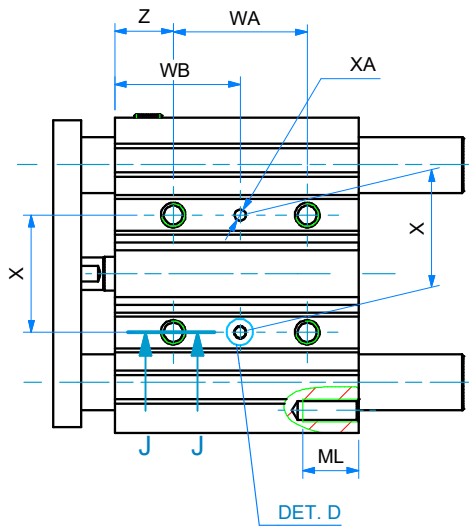
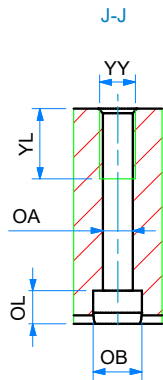
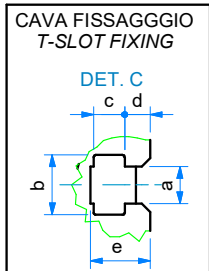
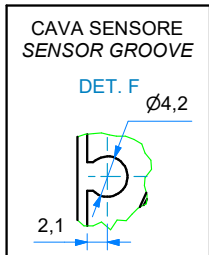

Ø	CORSE STANDARD - STANDARD STROKES
016	10 - 20 - 30 - 40 - 50 - 75 - 100 - 125 - 150 - 175 - 200 - 250
020	20 - 30 - 40 - 50 - 75 - 100 - 125 - 150 - 175 - 200 - 250 - 300 - 350 - 400
025	20 - 30 - 40 - 50 - 75 - 100 - 125 - 150 - 175 - 200 - 250 - 300 - 350 - 400
032	25 - 50 - 75 - 100 - 125 - 150 - 175 - 200 - 250 - 300 - 350 - 400
040	25 - 50 - 75 - 100 - 125 - 150 - 175 - 200 - 250 - 300 - 350 - 400
050	25 - 50 - 75 - 100 - 125 - 150 - 175 - 200 - 250 - 300 - 350 - 400
063	25 - 50 - 75 - 100 - 125 - 150 - 175 - 200 - 250 - 300 - 350 - 400

!!!: Le corse intermedie vengono realizzate con il corpo della corsa standard superiore e con distanziale interno per limitarne la corsa a quella richiesta.

Intermediate strokes are made with the profile of the standard superior stroke and with an internal spacer which limits the stroke to the required one.



## DIMENSIONI - DIMENSIONS

ø	16	20	25	32	40	50	63
A+ (corsa-stroke 0÷50)	42	53	53,5	97	97	106,5	106,5
A+ (corsa-stroke 75÷200)	64,5	84,5	85	102	102	118	118
B+	46	53	53,5	59,5	66	72	77
C+	33	37	37,5	37,5	44	44	49
ø DA	8	10	10	12	12	16	16
ø DB	10	12	16	20	20	25	25
E (corsa-stroke 0÷50)	0	0	0	37,5	31	34,5	29,5
E (corsa-stroke 75÷200)	18,5	31,5	31,5	42,5	36	46	41
FA	8	10	10	10	10	15	15
FB	5	6	6	12	12	13	13
G	30,5	36,8	42,8	49	55	65	79
GA	11	11,5	11,5	12	15	15	15,5
GB	8	9	10	9	12	12	13,5
H	64	84	94	113	121	149	163
HA	M4	M5	M5	M6	M6	M8	M10
HB	32,5	41,5	46,5	56	60	74	81
HC	32	42,5	47,5	57	61	75	82
J	15	18	21	24	27	32	39
K	15,5	18,8	21,8	25	28	33	40
L	22	24	30	34	40	46	58
MM	M5	M5	M6	M8	M8	M10	M10
ML	12	13	15	16	16	20	22
NN	M5	M5	M6	M8	M8	M10	M10
OA	4,2	5,2	5,2	6,5	6,5	8,5	8,5
OB	8	9,5	9,5	11	11	14	14
OL	4,5	5,5	5,5	7,5	7,5	9	9
P	M5	G1/8	G1/8	G1/8	G1/8	G1/4	G1/4
PA+	15	13,5	12,5	6,5	13	9	13
PB	10	11	14	16	18	21,5	28
PW	19	25	30	35,5	39,5	47	58
Q	16	18	26	30	30	40	50
R	54	70	78	96	104	130	130
S	25	30	40	45	45	60	70
T	62	81	91	110	118	146	158
U	46	54	64	78	86	110	124
VA	56	72	82	98	106	130	142
VB	38	44	50	63	72	92	110
VC	10,5	12,5	15	19,5	25	33	34
WA (corsa-stroke 0÷30)	24	24	24	24	24	24	28
WA (corsa-stroke 40÷100)	44	44	44	48	48	48	52
WA (corsa-stroke 125÷200)	110	120	120	124	124	124	128
WB (corsa-stroke 0÷30)	17	29	29	33	34	36	38
WB (corsa-stroke 40÷100)	27	39	39	45	46	48	50
WB (corsa-stroke 125÷200)	60	77	77	83	84	86	88
X ± 0,02	24	28	34	42	50	66	80
ø XA H9	3	3	4	4	4	5	5
XB	3,5	3,5	4,5	4,5	4,5	6	6
XC	3	3	3	3	3	4	4
XL	6	6	6	6	6	8	8
YY	M5	M6	M6	M8	M8	M10	M10
YL	10	12	12	16	16	20	22
Z	5	17	17	21	22	24	24
a	4,4	5,4	5,4	6,5	6,5	8,5	11
b	7,4	8,4	8,4	10,5	10,5	13,5	17,8
c	3,7	4,5	4,5	5,5	5,5	7,5	10
d	3,5	3,6	3,8	4,5	5	5,5	8
e	6,7	8,6	9	10,5	10,5	14,5	19,5

**COMPATTO GUIDATO D.E.M. CON CUSCINETTI A RICIRCOLO DI SFERE**

D.A.M. GUIDED COMPACT WITH RECIRCULATING BALL BEARINGS

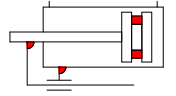

**CAVA SENSORE A C**  
**C-SLOT FOR SENSOR**



SERIE  
**E**

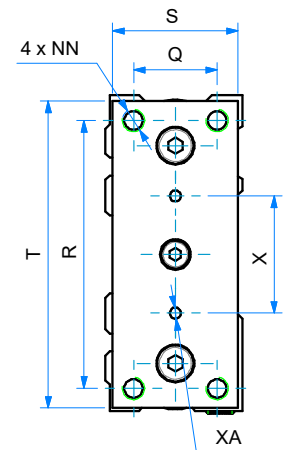
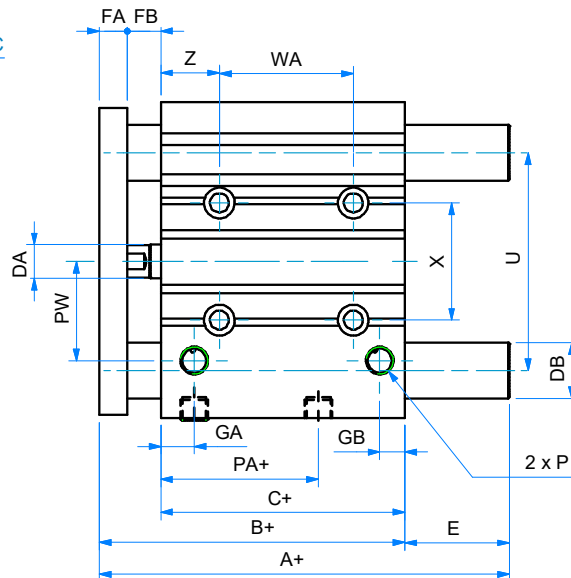
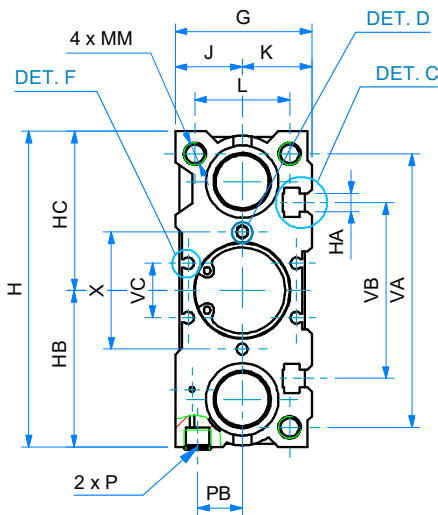
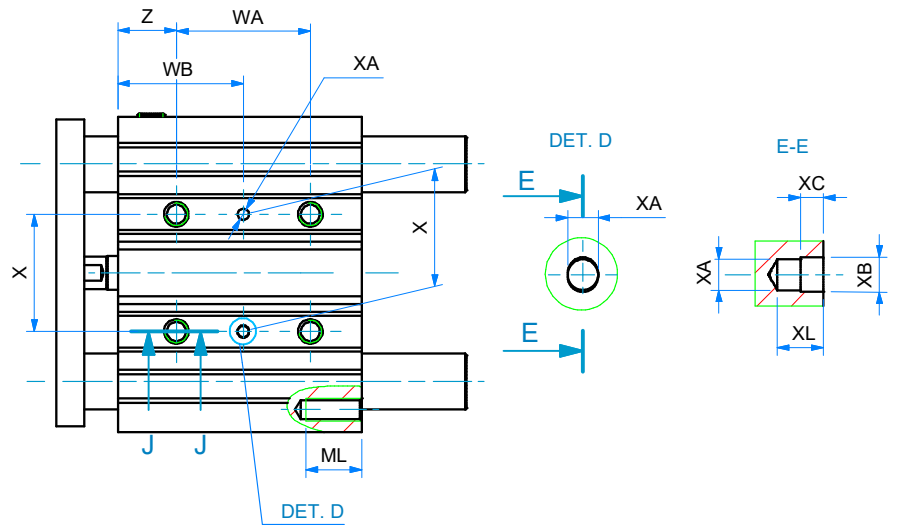
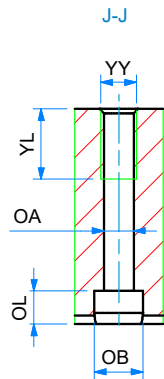
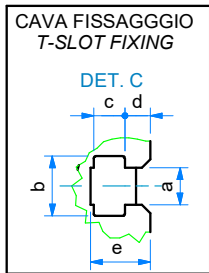
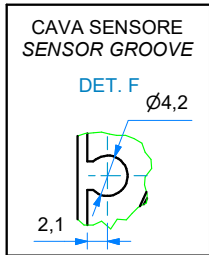

$\varnothing$	CORSE STANDARD - STANDARD STROKES
016	10 - 20 - 30 - 40 - 50 - 75 - 100 - 125 - 150 - 175 - 200 - 250
020	20 - 30 - 40 - 50 - 75 - 100 - 125 - 150 - 175 - 200 - 250 - 300 - 350 - 400
025	20 - 30 - 40 - 50 - 75 - 100 - 125 - 150 - 175 - 200 - 250 - 300 - 350 - 400
032	25 - 50 - 75 - 100 - 125 - 150 - 175 - 200 - 250 - 300 - 350 - 400
040	25 - 50 - 75 - 100 - 125 - 150 - 175 - 200 - 250 - 300 - 350 - 400
050	25 - 50 - 75 - 100 - 125 - 150 - 175 - 200 - 250 - 300 - 350 - 400
063	25 - 50 - 75 - 100 - 125 - 150 - 175 - 200 - 250 - 300 - 350 - 400

!!!: Le corse intermedie vengono realizzate con il corpo della corsa standard superiore e con distanziale interno per limitarne la corsa a quella richiesta.

Intermediate strokes are made with the profile of the standard superior stroke and with an internal spacer which limits the stroke to the required one.

## DIMENSIONI - DIMENSIONS

## CON CUSCINETTI A RICIRCOLO DI SFERE - WITH RECIRCULATING BALL BEARINGS

ø	16	20	25	32	40	50	63
A+ (corsa-stroke 0÷30)	49	63	69,5	-	-	-	-
A+ (corsa-stroke 40÷100)	65	80	86	-	-	-	-
A+ (corsa-stroke 125÷200)	-	104	104,5	-	-	-	-
A+ (corsa-stroke 0÷50)	-	-	-	81	81	93	93
A+ (corsa-stroke 75÷100)	-	-	-	98	98	114	114
A+ (corsa-stroke 125÷200)	-	-	-	118	118	134	134
B+	46	53	53,5	59,5	66	72	77
C+	33	37	37,5	37,5	44	44	49
ø DA	8	10	10	12	12	16	16
ø DB	8	12	14	20	20	25	25
E (corsa-stroke 0÷30)	3	10	16	-	-	-	-
E (corsa-stroke 40÷100)	19	27	32,5	-	-	-	-
E (corsa-stroke 125÷200)	-	51	51	-	-	-	-
E (corsa-stroke 0÷50)	-	-	-	21,5	15	21	16
E (corsa-stroke 75÷100)	-	-	-	38,5	32	42	37
E (corsa-stroke 125÷200)	-	-	-	58,5	52	62	57
FA	8	10	10	10	10	15	15
FB	5	6	6	12	12	13	13
G	30,5	36,8	42,8	49	55	65	79
GA	11	11,5	11,5	12	15	15	15,5
GB	8	9	10	9	12	12	13,5
H	64	84	94	113	121	149	163
HA	M4	M5	M5	M6	M6	M8	M10
HB	32,5	41,5	46,5	56	60	74	81
HC	32	42,5	47,5	57	61	75	82
J	15	18	21	24	27	32	39
K	15,5	18,8	21,8	25	28	33	40
L	22	24	30	34	40	46	58
MM	M5	M5	M6	M8	M8	M10	M10
ML	12	13	15	16	16	20	22
NN	M5	M5	M6	M8	M8	M10	M10
OA	4,2	5,2	5,2	6,5	6,5	8,5	8,5
OB	8	9,5	9,5	11	11	14	14
OL	4,5	5,5	5,5	7,5	7,5	9	9
P	M5	G1/8	G1/8	G1/8	G1/8	G1/4	G1/4
PA+	15	13,5	12,5	6,5	13	9	13
PB	10	11	14	16	18	21,5	28
PW	19	25	30	35,5	39,5	47	58
Q	16	18	26	30	30	40	50
R	54	70	78	96	104	130	130
S	25	30	40	45	45	60	70
T	62	81	91	110	118	146	158
U	46	54	64	78	86	110	124
VA	56	72	82	98	106	130	142
VB	38	44	50	63	72	92	110
VC	10,5	12,5	15	19,5	25	33	34
WA (corsa-stroke 0÷30)	24	24	24	24	24	24	28
WA (corsa-stroke 40÷100)	44	44	44	48	48	48	52
WA (corsa-stroke 125÷200)	110	120	120	124	124	124	128
WB (corsa-stroke 0÷30)	17	29	29	33	34	36	38
WB (corsa-stroke 40÷100)	27	39	39	45	46	48	50
WB (corsa-stroke 125÷200)	60	77	77	83	84	86	88
X ± 0,02	24	28	34	42	50	66	80
ø XA H9	3	3	4	4	4	5	5
XB	3,5	3,5	4,5	4,5	4,5	6	6
XC	3	3	3	3	3	4	4
XL	6	6	6	6	6	8	8
YY	M5	M6	M6	M8	M8	M10	M10
YL	10	12	12	16	16	20	22
Z	5	17	17	21	22	24	24
a	4,4	5,4	5,4	6,5	6,5	8,5	11
b	7,4	8,4	8,4	10,5	10,5	13,5	17,8
c	3,7	4,5	4,5	5,5	5,5	7,5	10
d	3,5	3,6	3,8	4,5	5	5,5	8
e	6,7	8,6	9	10,5	10,5	14,5	19,5

**COMPATTO GUIDATO D.E.M.**

**D.A.M. GUIDED COMPACT**

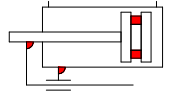

**CAVA SENSORE A T**  
**T-SLOT FOR SENSOR**

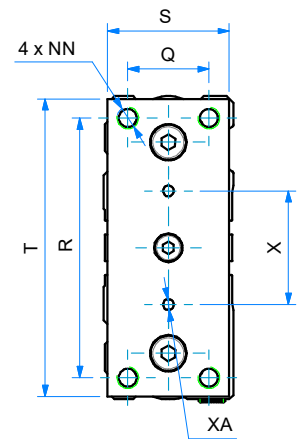
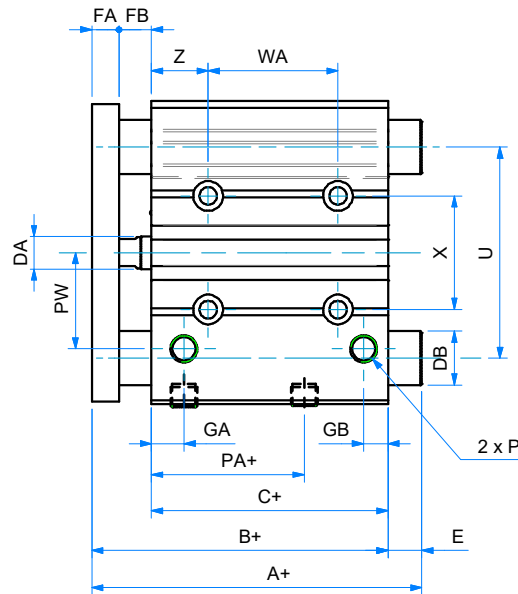
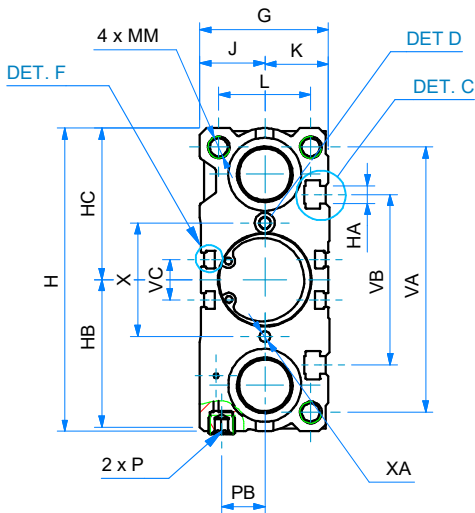
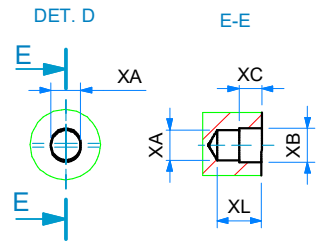
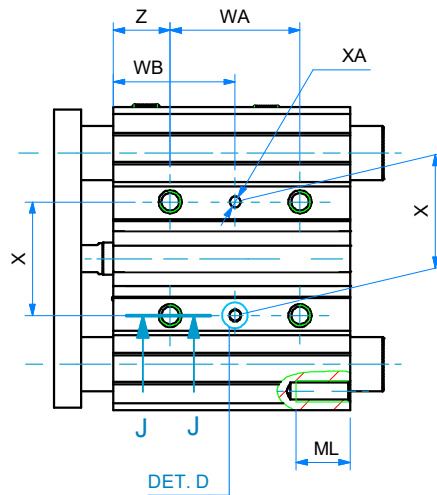
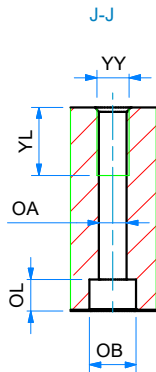
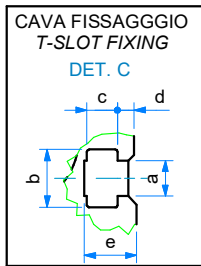
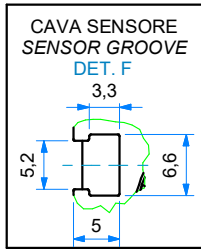

Ø	CORSE STANDARD - STANDARD STROKES
016	10 - 20 - 30 - 40 - 50 - 75 - 100 - 125 - 150 - 175 - 200 - 250
020	20 - 30 - 40 - 50 - 75 - 100 - 125 - 150 - 175 - 200 - 250 - 300 - 350 - 400
025	20 - 30 - 40 - 50 - 75 - 100 - 125 - 150 - 175 - 200 - 250 - 300 - 350 - 400
032	25 - 50 - 75 - 100 - 125 - 150 - 175 - 200 - 250 - 300 - 350 - 400
040	25 - 50 - 75 - 100 - 125 - 150 - 175 - 200 - 250 - 300 - 350 - 400
050	25 - 50 - 75 - 100 - 125 - 150 - 175 - 200 - 250 - 300 - 350 - 400
063	25 - 50 - 75 - 100 - 125 - 150 - 175 - 200 - 250 - 300 - 350 - 400

!!!: Le corse intermedie vengono realizzate con il corpo della corsa standard superiore e con distanziale interno per limitarne la corsa a quella richiesta.

Intermediate strokes are made with the profile of the standard superior stroke and with an internal spacer which limits the stroke to the required one.

# E1DM

## DIMENSIONI - DIMENSIONS

## CON BOCCOLE IN BRONZO - WITH BRONZE BUSH

Ø	16	20	25	32	40	50	63
<b>A+ (corsa-stroke 0÷50)</b>	42	53	53,5	97	97	106,5	106,5
<b>A+ (corsa-stroke 75÷200)</b>	64,5	84,5	85	102	102	118	118
<b>A+ (corsa-stroke 250÷400)</b>							
<b>B+</b>	46	53	53,5	59,5	66	72	77
<b>C+</b>	33	37	37,5	37,5	44	44	49
<b>Ø DA</b>	8	10	10	12	12	16	16
<b>Ø DB</b>	10	12	16	20	20	25	25
<b>E (corsa-stroke 0÷50)</b>	0	0	0	37,5	31	34,5	29,5
<b>E (corsa-stroke 75÷200)</b>	18,5	31,5	31,5	42,5	36	46	41
<b>E (corsa-stroke 250÷400)</b>							
<b>FA</b>	8	10	10	10	10	15	15
<b>FB</b>	5	6	6	12	12	13	13
<b>G</b>	30	36	42	48	54	64	78
<b>GA</b>	11	11,5	11,5	12	15	15	15,5
<b>GB</b>	8	9	10	9	12	12	13,5
<b>H</b>	64	84	94	113	121	149	163
<b>HA</b>	M4	M5	M5	M6	M6	M8	M10
<b>HB</b>	32,5	41,5	46,5	56	60	74	81
<b>HC</b>	32	42,5	47,5	57	61	75	82
<b>J</b>	15	18	21	24	27	32	39
<b>K</b>	15	18	21	24	27	32	39
<b>L</b>	22	24	30	34	40	46	58
<b>MM</b>	M5	M5	M6	M8	M8	M10	M10
<b>ML</b>	12	13	15	16	16	20	22
<b>NN</b>	M5	M5	M6	M8	M8	M10	M10
<b>OA</b>	4,2	5,2	5,2	6,5	6,5	8,5	8,5
<b>OB</b>	8	9,5	9,5	11	11	14	14
<b>OL</b>	4,5	5,5	5,5	7,5	7,5	9	9
<b>P</b>	M5	G1/8	G1/8	G1/8	G1/8	G1/4	G1/4
<b>PA+</b>	15	13,5	12,5	6,5	13	9	13
<b>PB</b>	10	11	14	16	18	21,5	28
<b>PW</b>	19	25	30	35,5	39,5	47	58
<b>Q</b>	16	18	26	30	30	40	50
<b>R</b>	54	70	78	96	104	130	130
<b>S</b>	25	30	40	45	45	60	70
<b>T</b>	62	81	91	110	118	146	158
<b>U</b>	46	54	64	78	86	110	124
<b>VA</b>	56	72	82	98	106	130	142
<b>VB</b>	38	44	50	63	72	92	110
<b>VC</b>	10,5	12,5	15	19,5	25	33	34
<b>WA (corsa-stroke 0÷30)</b>	24	24	24	24	24	24	28
<b>WA (corsa-stroke 40÷100)</b>	44	44	44	48	48	48	52
<b>WA (corsa-stroke 125÷200)</b>	110	120	120	124	124	124	128
<b>WB (corsa-stroke 0÷30)</b>	17	29	29	33	34	36	38
<b>WB (corsa-stroke 40÷100)</b>	27	39	39	45	46	48	50
<b>WB (corsa-stroke 125÷200)</b>	60	77	77	83	84	86	88
<b>X ± 0,02</b>	24	28	34	42	50	66	80
<b>Ø XA H9</b>	3	3	4	4	4	5	5
<b>XB</b>	3,5	3,5	4,5	4,5	4,5	6	6
<b>XC</b>	3	3	3	3	3	4	4
<b>XL</b>	6	6	6	6	6	8	8
<b>YY</b>	M5	M6	M6	M8	M8	M10	M10
<b>YL</b>	10	12	12	16	16	20	22
<b>Z</b>	5	17	17	21	22	24	24
<b>a</b>	4,4	5,4	5,4	6,5	6,5	8,5	11
<b>b</b>	7,4	8,4	8,4	10,5	10,5	13,5	17,8
<b>c</b>	3,7	4,5	4,5	5,5	5,5	7,5	10
<b>d</b>	3,5	3,6	3,8	4,5	5	5,5	8
<b>e</b>	6,7	8,6	9	10,5	10,5	14,5	19,5

SERIE

**E**

**COMPATTO GUIDATO D.E.M. CON CUSCINETTI A RICIRCOLO DI SFERE**

D.A.M. GUIDED COMPACT WITH RECIRCULATING BALL BEARINGS

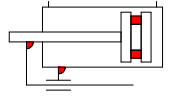

**CAVA SENSORE A T**  
**T-SLOT FOR SENSOR**

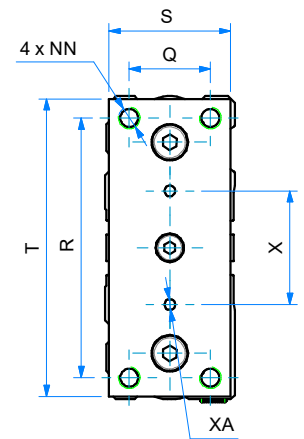
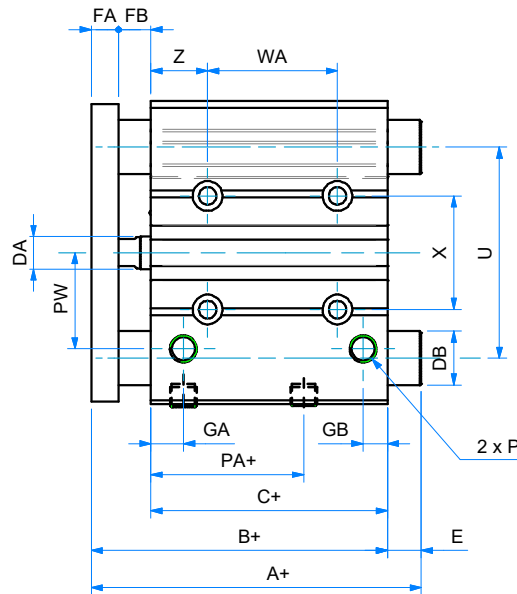
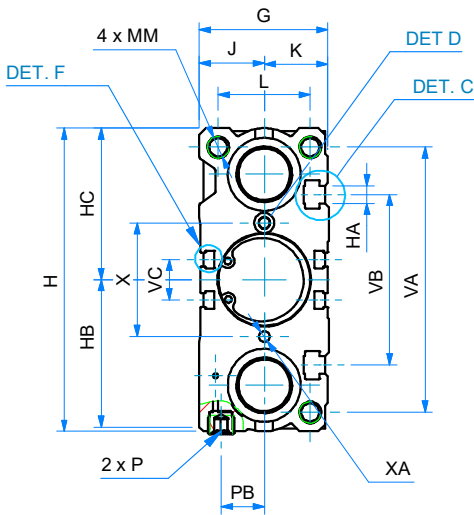
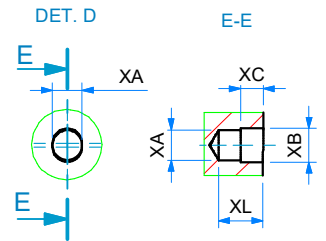
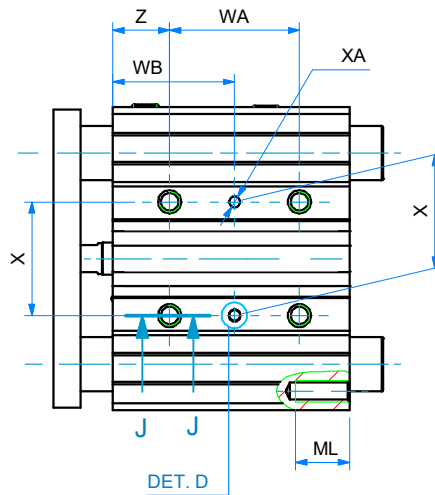
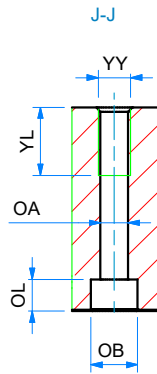
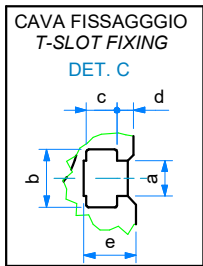
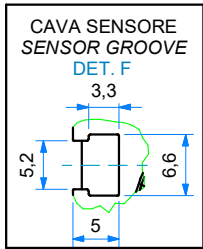

**0 CORSE STANDARD - STANDARD STROKES**

<b>016</b>	10 - 20 - 30 - 40 - 50 - 75 - 100 - 125 - 150 - 175 - 200 - 250
<b>020</b>	20 - 30 - 40 - 50 - 75 - 100 - 125 - 150 - 175 - 200 - 250 - 300 - 350 - 400
<b>025</b>	20 - 30 - 40 - 50 - 75 - 100 - 125 - 150 - 175 - 200 - 250 - 300 - 350 - 400
<b>032</b>	25 - 50 - 75 - 100 - 125 - 150 - 175 - 200 - 250 - 300 - 350 - 400
<b>040</b>	25 - 50 - 75 - 100 - 125 - 150 - 175 - 200 - 250 - 300 - 350 - 400
<b>050</b>	25 - 50 - 75 - 100 - 125 - 150 - 175 - 200 - 250 - 300 - 350 - 400
<b>063</b>	25 - 50 - 75 - 100 - 125 - 150 - 175 - 200 - 250 - 300 - 350 - 400

!!!: Le corse intermedie vengono realizzate con il corpo della corsa standard superiore e con distanziale interno per limitarne la corsa a quella richiesta.

Intermediate strokes are made with the profile of the standard superior stroke and with an internal spacer which limits the stroke to the required one.

## DIMENSIONI - DIMENSIONS

## CON CUSCINETTI A RICIRCOLO DI SFERE - WITH RECIRCULATING BALL BEARINGS

	16	20	25	32	40	50	63
ø							
A+ (corsa-stroke 0÷30)	49	63	69,5	-	-	-	-
A+ (corsa-stroke 40÷100)	65	80	86	-	-	-	-
A+ (corsa-stroke 125÷200)	-	104	104,5	-	-	-	-
A+ (corsa-stroke 0÷50)	-	-	-	81	81	93	93
A+ (corsa-stroke 75÷100)	-	-	-	98	98	114	114
A+ (corsa-stroke 125÷200)	-	-	-	118	118	134	134
A+ (corsa-stroke 250÷400)	-	-	-	-	-	-	-
B+	46	53	53,5	59,5	66	72	77
C+	33	37	37,5	37,5	44	44	49
ø DA	8	10	10	12	12	16	16
ø DB	8	12	14	20	20	25	25
E (corsa-stroke 0÷30)	3	10	16	-	-	-	-
E (corsa-stroke 40÷100)	19	27	32,5	-	-	-	-
E (corsa-stroke 125÷200)	-	51	51	-	-	-	-
E (corsa-stroke 0÷50)	-	-	-	21,5	15	21	16
E (corsa-stroke 75÷100)	-	-	-	38,5	32	42	37
E (corsa-stroke 125÷200)	-	-	-	58,5	52	62	57
E (corsa-stroke 250÷400)	-	-	-	-	-	-	-
FA	8	10	10	10	10	15	15
FB	5	6	6	12	12	13	13
G	30	36	42	48	54	64	78
GA	11	11,5	11,5	12	15	15	15,5
GB	8	9	10	9	12	12	13,5
H	64	84	94	113	121	149	163
HA	M4	M5	M5	M6	M6	M8	M10
HB	32,5	41,5	46,5	56	60	74	81
HC	32	42,5	47,5	57	61	75	82
J	15	18	21	24	27	32	39
K	15	18	21	24	27	32	39
L	22	24	30	34	40	46	58
MM	M5	M5	M6	M8	M8	M10	M10
ML	12	13	15	16	16	20	22
NN	M5	M5	M6	M8	M8	M10	M10
OA	4,2	5,2	5,2	6,5	6,5	8,5	8,5
OB	8	9,5	9,5	11	11	14	14
OL	4,5	5,5	5,5	7,5	7,5	9	9
P	M5	G1/8	G1/8	G1/8	G1/8	G1/4	G1/4
PA+	15	13,5	12,5	6,5	13	9	13
PB	10	11	14	16	18	21,5	28
PW	19	25	30	35,5	39,5	47	58
Q	16	18	26	30	30	40	50
R	54	70	78	96	104	130	130
S	25	30	40	45	45	60	70
T	62	81	91	110	118	146	158
U	46	54	64	78	86	110	124
VA	56	72	82	98	106	130	142
VB	38	44	50	63	72	92	110
VC	10,5	12,5	15	19,5	25	33	34
WA (corsa-stroke 0÷30)	24	24	24	24	24	24	28
WA (corsa-stroke 40÷100)	44	44	44	48	48	48	52
WA (corsa-stroke 125÷200)	110	120	120	124	124	124	128
WA (corsa-stroke 250÷400)	-	-	-	-	-	-	-
WB (corsa-stroke 0÷30)	17	29	29	33	34	36	38
WB (corsa-stroke 40÷100)	27	39	39	45	46	48	50
WB (corsa-stroke 125÷200)	60	77	77	83	84	86	88
WB (corsa-stroke 250÷400)	-	-	-	-	-	-	-
X ± 0,02	24	28	34	42	50	66	80
ø XA H9	3	3	4	4	4	5	5
XB	3,5	3,5	4,5	4,5	4,5	6	6
XC	3	3	3	3	3	4	4
XL	6	6	6	6	6	8	8
YY	M5	M6	M6	M8	M8	M10	M10
YL	10	12	12	16	16	20	22
Z	5	17	17	21	22	24	24
a	4,4	5,4	5,4	6,5	6,5	8,5	11
b	7,4	8,4	8,4	10,5	10,5	13,5	17,8
c	3,7	4,5	4,5	5,5	5,5	7,5	10
d	3,5	3,6	3,8	4,5	5	5,5	8
e	6,7	8,6	9	10,5	10,5	14,5	19,5

**COMPATTO GUIDATO D.E.M. CON BOCCOLE IN BRONZO AMMORTIZZATO**

D.A.M. GUIDED COMPACT WITH BRONZE BUSHES CUSHIONED

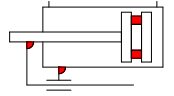

**CAVA SENSORE A T**  
**T-SLOT FOR SENSOR**

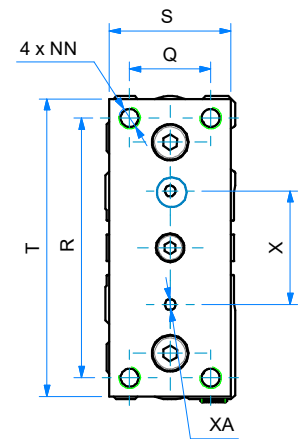
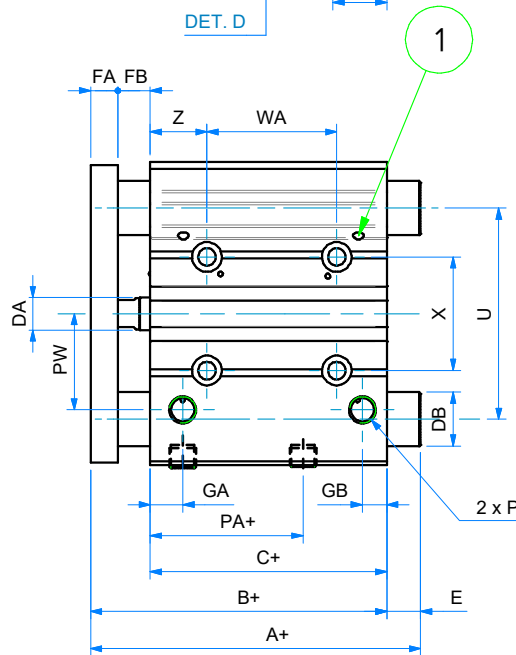
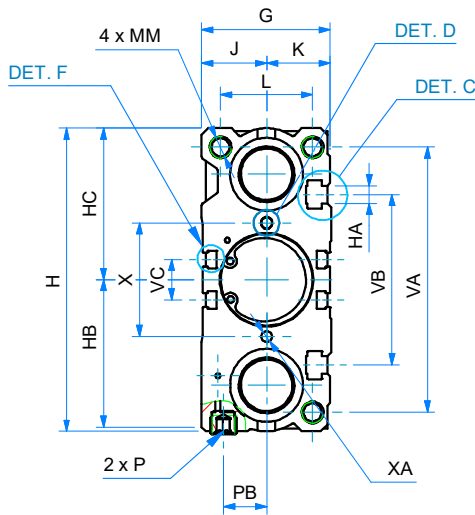
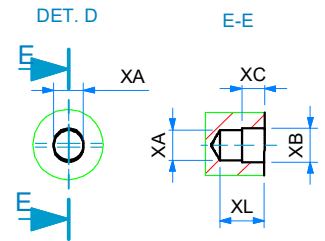
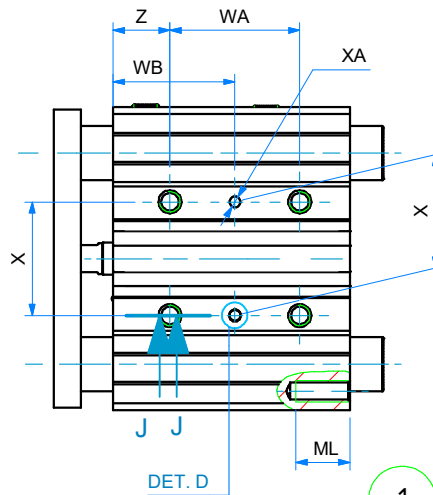
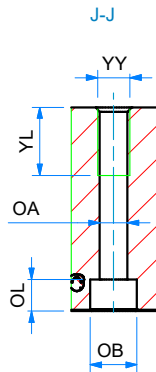
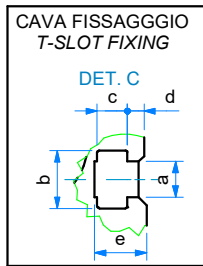
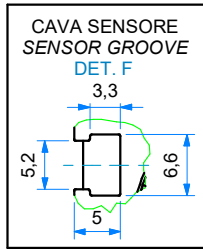

① Vite regolazione ammortizzo - Cushioning adjustment screw

**9 CORSE STANDARD - STANDARD STROKES**

<b>016</b>	25 - 50 - 75 - 100
<b>020</b>	25 - 50 - 75 - 100 - 125 - 150 - 175 - 200 - 250
<b>025</b>	25 - 50 - 75 - 100 - 125 - 150 - 175 - 200 - 250
<b>032</b>	25 - 50 - 75 - 100 - 125 - 150 - 175 - 200 - 250
<b>040</b>	25 - 50 - 75 - 100 - 125 - 150 - 175 - 200 - 250
<b>050</b>	25 - 50 - 75 - 100 - 125 - 150 - 175 - 200 - 250
<b>063</b>	25 - 50 - 75 - 100 - 125 - 150 - 175 - 200 - 250

!!!: Le corse intermedie della versione ammortizzata non sono realizzabili (per ulteriori informazioni contattare l'ufficio commerciale)

Intermediate strokes of versions with cushioning are not possible (for further information, please contact our sales department)



## DIMENSIONI - DIMENSIONS

## CON BOCCOLE IN BRONZO - WITH BRONZE BUSH

ø	16	20	25	32	40	50	63
A+ (corsa-stroke 0÷25)	71	78	78,5	97	97	106,5	106,5
A+ (corsa-stroke >25÷50)	71	86,5	87	127	127	131,5	131,5
A+ (corsa-stroke 75÷200)	71	84,5	85	102	102	118	118
A+ (corsa-stroke 250)	-						
B+	71	78	78,5	84,5	91	97	102
C+	58	62	62,5	62,5	69	69	74
øDA	8	10	10	12	12	16	16
øDB	10	12	16	20	20	25	25
E (corsa-stroke 0÷25)	0	0	0	12,5	6	9,5	4,5
E (corsa-stroke >25÷50)	0	8,5	8,5	42,5	36	34,5	29,5
E (corsa-stroke 75÷200)	0	6,5	6,5	17,5	11	21	16
E (corsa-stroke 250)	-						
FA	8	10	10	10	10	15	15
FB	5	6	6	12	12	13	13
G	30	36	42	48	54	64	78
GA	11	11,5	11,5	12	15	15	15,5
GB	8	9	10	9	12	12	13,5
H	64	84	94	113	121	149	163
HA	M4	M5	M5	M6	M6	M8	M10
HB	32,5	41,5	46,5	56	60	74	81
HC	32	42,5	47,5	57	61	75	82
J	15	18	21	24	27	32	39
K	15	18	21	24	27	32	39
L	22	24	30	34	40	46	58
MM	M5	M5	M6	M8	M8	M10	M10
ML	12	13	15	16	16	20	22
NN	M5	M5	M6	M8	M8	M10	M10
OA	4,2	5,2	5,2	6,5	6,5	8,5	8,5
OB	8	9,5	9,5	11	11	14	14
OL	4,5	5,5	5,5	7,5	7,5	9	9
P	M5	G1/8	G1/8	G1/8	G1/8	G1/4	G1/4
PA+	40	38,5	37,5	31,5	38	34	38
PB	10	10,5	13,5	16	18	21,5	28
PW	19	25	30	35,5	39,5	47	58
Q	16	18	26	30	30	40	50
R	54	70	78	96	104	130	130
S	25	30	40	45	45	60	70
T	62	81	91	110	118	146	158
U	46	54	64	78	86	110	124
VA	56	72	82	98	106	130	142
VB	38	44	50	63	72	92	110
VC	10,5	12,5	15	19,5	25	33	34
WA (corsa-stroke 0÷75)	44	44	44	48	48	48	52
WA (corsa-stroke 100÷175)	110	120	120	124	124	124	128
WA (corsa-stroke 200)	-	200	200	200	200	200	200
WA (corsa-stroke 250)	-						
WB (corsa-stroke 0÷75)	27	39	39	45	46	48	50
WB (corsa-stroke 100÷175)	60	77	77	83	84	86	88
WB (corsa-stroke 200)	-	117	117	121	122	124	124
WB (corsa-stroke 250)	-						
X ±0,02	24	28	34	42	50	66	80
øXA H9	3	3	4	4	4	5	5
XB	3,5	3,5	4,5	4,5	4,5	6	6
XC	3	3	3	3	3	4	4
XL	6	6	6	6	6	8	8
YY	M5	M6	M6	M8	M8	M10	M10
YL	10	12	12	16	16	20	22
Z	5	17	17	21	22	24	24
a	4,4	5,4	5,4	6,5	6,5	8,5	11
b	7,4	8,4	8,4	10,5	10,5	13,5	17,8
c	3,7	4,5	4,5	5,5	5,5	7,5	10
d	3,5	3,6	3,8	4,5	5	5,5	8
e	6,7	8,6	9	10,5	10,5	14,5	19,5

**D.E.M. CON CUSCINETTI A RICIRCOLO DI SFERE AMMORTIZZATO**

D.A.M. CUSHIONED WITH RECIRCULATING BALL BEARINGS

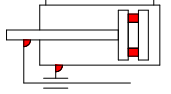

**CAVA SENSORE A T**  
**T-SLOT FOR SENSOR**

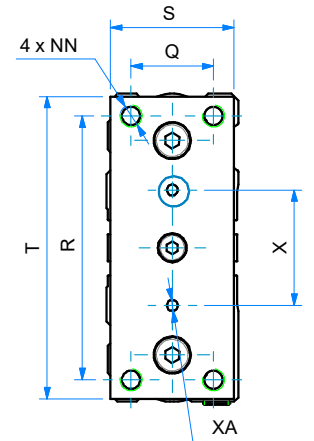
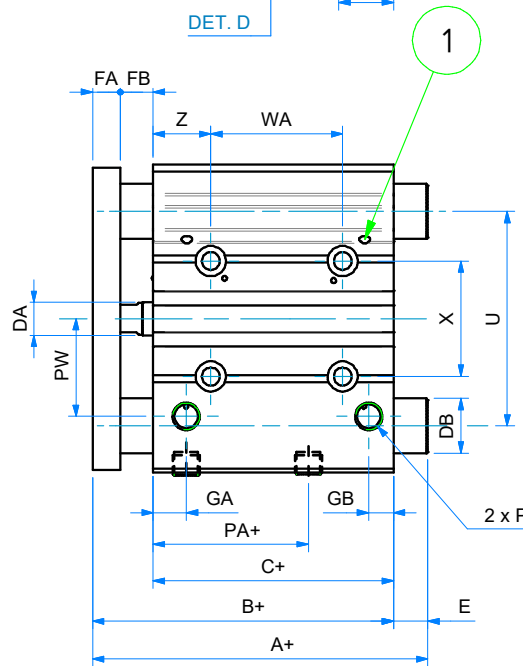
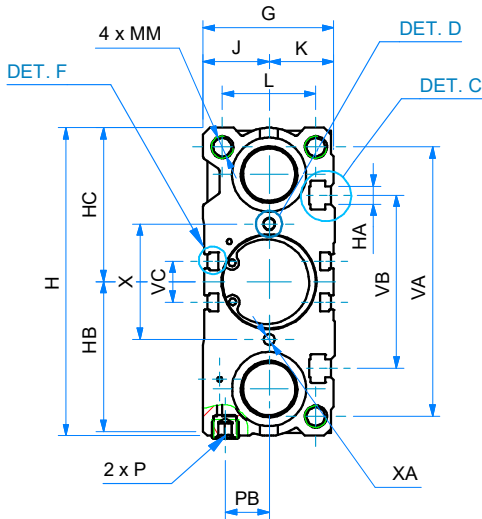
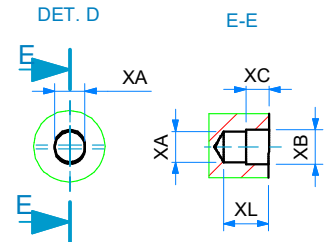
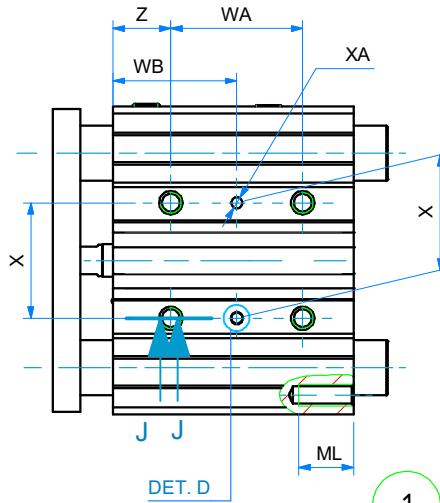
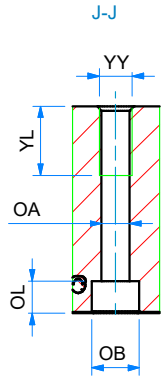
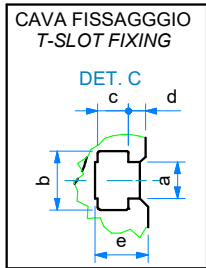
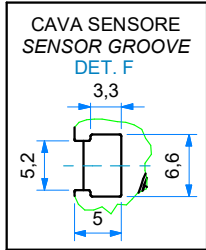

① Vite regolazione ammortizzo - Cushioning adjustment screw

**9 CORSE STANDARD - STANDARD STROKES**

<b>016</b>	25 - 50 - 75 - 100
<b>020</b>	25 - 50 - 75 - 100 - 125 - 150 - 175 - 200 - 250
<b>025</b>	25 - 50 - 75 - 100 - 125 - 150 - 175 - 200 - 250
<b>032</b>	25 - 50 - 75 - 100 - 125 - 150 - 175 - 200 - 250
<b>040</b>	25 - 50 - 75 - 100 - 125 - 150 - 175 - 200 - 250
<b>050</b>	25 - 50 - 75 - 100 - 125 - 150 - 175 - 200 - 250
<b>063</b>	25 - 50 - 75 - 100 - 125 - 150 - 175 - 200 - 250

!!!: Le corse intermedie della versione ammortizzata non sono realizzabili (per ulteriori informazioni contattare l'ufficio commerciale)

Intermediate strokes of versions with cushioning are not possible (for further information, please contact our sales department)

## DIMENSIONI - DIMENSIONS

## CON CUSCINETTI A RICIRCOLO DI SFERE - WITH RECIRCULATING BALL BEARINGS

Ø	16	20	25	32	40	50	63
A+ (corsa-stroke 0÷25)	71	95	100,5	84,5	91	97	102
A+ (corsa-stroke 50)	71	80	85,5	123	123	127,5	127,5
A+ (corsa-stroke 75)	71	80	85,5	98	98	114	114
A+ (corsa-stroke 100)	71	99	104,5	115,5	115,5	159	159
A+ (corsa-stroke >125)	-	104	104,5	118	118	134	134
B+	71	78	78,5	84,5	91	97	102
C+	58	62	62,5	62,5	69	69	74
øDA	8	10	10	12	12	16	16
øDB	8	12	14	20	20	25	25
E (corsa-stroke 0÷25)	0	17	22	0	0	0	0
E (corsa-stroke 50)	0	2	7	38,5	32	30,5	25,5
E (corsa-stroke 75)	0	2	7	13,5	7	17	12
E (corsa-stroke 100)	0	21	26	31	24,5	62	57
E (corsa-stroke >125)	-	26	26	33,5	27	37	32
FA	8	10	10	10	10	15	15
FB	5	6	6	12	12	13	13
G	30	36	42	48	54	64	78
GA	11	11,5	11,5	12	15	15	15,5
GB	8	9	10	9	12	12	13,5
H	64	84	94	113	121	149	163
HA	M4	M5	M5	M6	M6	M8	M10
HB	32,5	41,5	46,5	56	60	74	81
HC	32	42,5	47,5	57	61	75	82
J	15	18	21	24	27	32	39
K	15	18	21	24	27	32	39
L	22	24	30	34	40	46	58
MM	M5	M5	M6	M8	M8	M10	M10
ML	12	13	15	16	16	20	22
NN	M5	M5	M6	M8	M8	M10	M10
OA	4,2	5,2	5,2	6,5	6,5	8,5	8,5
OB	8	9,5	9,5	11	11	14	14
OL	4,5	5,5	5,5	7,5	7,5	9	9
P	M5	G1/8	G1/8	G1/8	G1/8	G1/4	G1/4
PA+	40	38,5	37,5	31,5	38	34	38
PB	10	10,5	13,5	16	18	21,5	28
PW	19	25	30	35,5	39,5	47	58
Q	16	18	26	30	30	40	50
R	54	70	78	96	104	130	130
S	25	30	40	45	45	60	70
T	62	81	91	110	118	146	158
U	46	54	64	78	86	110	124
VA	56	72	82	98	106	130	142
VB	38	44	50	63	72	92	110
VC	10,5	12,5	15	19,5	25	33	34
WA (corsa-stroke 0÷75)	44	44	44	48	48	48	52
WA (corsa-stroke 100÷175)	110	120	120	124	124	124	128
WA (corsa-stroke 200)	-	200	200	200	200	200	200
WB (corsa-stroke 0÷75)	27	39	39	45	46	48	50
WB (corsa-stroke 100÷175)	60	77	77	83	84	86	88
WB (corsa-stroke 200)	-	117	117	121	122	124	124
X ±0,02	24	28	34	42	50	66	80
øXA H9	3	3	4	4	4	5	5
XB	3,5	3,5	4,5	4,5	4,5	6	6
XC	3	3	3	3	3	4	4
XL	6	6	6	6	6	8	8
YY	M5	M6	M6	M8	M8	M10	M10
YL	10	12	12	16	16	20	22
Z	5	17	17	21	22	24	24
a	4,4	5,4	5,4	6,5	6,5	8,5	11
b	7,4	8,4	8,4	10,5	10,5	13,5	17,8
c	3,7	4,5	4,5	5,5	5,5	7,5	10
d	3,5	3,6	3,8	4,5	5	5,5	8
e	6,7	8,6	9	10,5	10,5	14,5	19,5

## SENSORI MAGNETICI (versione E1 CAVA T)

### MAGNETIC SENSORS (E1 version T-SLOT)

#### CARATTERISTICHE - CHARACTERISTICS

CODICE - CODE	36.SEN06 36.SEN06.L6	36.SEN07	36.SEN08	36.SEN09 36.SEN09.L6 36.SEN09.L10
TIPO - TYPE	REED	REED	ELETTRONICO ELECTRONIC	ELETTRONICO ELECTRONIC
Modello elettrico - Electrical design	AC/DC PNP/NPN	AC/DC PNP/NPN	DC PNP	DC PNP
Funzione dell'uscita - Output	NO	NO	NO	NO
Tensione di esercizio - Operating voltage	[V] 5...120 AC/DC	5...60 DC / 5...50 AC	10...30 DC	10...30 DC
Capacità di corrente - Current rating	[mA] 100*	100*	100	100
Sensibilità di reazione - Magnetic sensitivity	[mT] 2,1	2,1	2,8	2,8
Velocità di passaggio - Travel speed	[m/s] > 10	> 10	> 10	> 10
Protezione da cortocircuito - Short-circuit proof	no	no	si - yes	si - yes
Protetto da inversione di polarità Reverse polarity protection	si - yes	si - yes	si - yes	si - yes
Resistente a sovraccarico - Overload protection	no	no	si - yes	si - yes
Caduta di tensione - Voltage drop	[V] < 5	< 5	< 2,5	< 2,5
Isteresi - Hysteresis	1	1	< 1,5	< 1,5
Riproducibilità - Repeatability	[mm] ± 0,2	± 0,2	< 0,2	< 0,2
Corrente assorbita - Current consumption	[mA] -	-	< 10	< 10
Tempo di commutazione - Make time	[ms] ≤ 0,6	≤ 0,6	-	-
Tempo di riapertura - Fall time	[ms] ≤ 0,1	≤ 0,1	-	-
Potenza max - Switching power max	[W] 10	10	-	-
Cicli di commutazione con connessione a PLC Switching cycles when connected to PLC	[mln] ≤ 40	≤ 40	-	-
Frequenza di commutazione - Switching frequency	[Hz] 1.000	1.000	> 10.000	> 10.000
Temperatura ambiente - Ambient temperature	[°C] -25...70	-25...70	-25...80	-25...80
Grado/Classe di protezione - Protection	IP67, II	IP67, II	IP67, III	IP67, III
Materiale involucro - Housing material	PA (poliammide - polyamide)			
Materiale eccentrico di fissaggio - Fastening clamp	inox - stainless steel			
Indicazione della funzione Stato di commutazione Function display Switching status	LED	giallo - yellow		
Collegamento - Connection	cavo PUR - PUR cable 2x0,14 mm <sup>2</sup> 2 m (.L6 = 6 m)	cavo PUR - PUR cable connettore M8- M8 connector 0,3 m	cavo PUR - PUR cable connettore M8- M8 connector 0,3 m	cavo PUR - PUR cable 3x0,14 mm <sup>2</sup> 2 m (.L6 = 6 m   .L10 = 10 m)
Peso - Weight	[g] 31,3 69	12	12,1	27,4 73,5 122,4

Accessori inclusi: Segnaposto in gomma, fascetta fermacavo - Accessories included: Rubber placeholder, cable clip

\*: necessario circuito di protezione esterno per carico induttivo (valvola, relè, ecc...) - External protective circuit for inductive load (valve, contactor, etc...) necessary.

REED: nessuna funzione LED in caso di inversione di polarità nel funzionamento DC. - No LED function in case of polarity reversal in DC operation.

**CONTATTO REED (2 FILI)**

36.SEN06

36.SEN06.L6

**REED CONTACT (2 WIRES)**

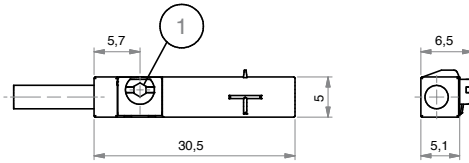

1= ECCENTRICO DI FISSAGGIO - FASTENING CLAMP

CABLAGGIO - WIRING

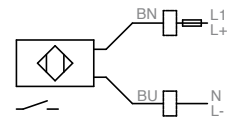

BN= MARRONE - BROWN  
BU= BLU - BLUE

**CONTATTO REED (CONNETTORE M8)**

36.SEN07

**REED CONTACT (M8 CONNECTOR)**

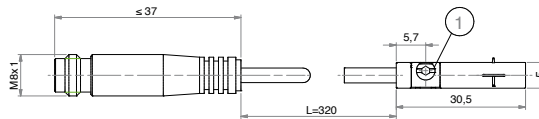

1= ECCENTRICO DI FISSAGGIO - FASTENING CLAMP

CABLAGGIO - WIRING

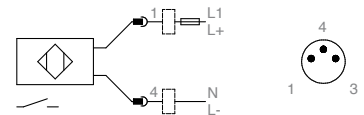

BN= MARRONE - BROWN  
BU= BLU - BLUE

SERIE  
**E**

**CONTATTO PNP (CONNETTORE M8)**

36.SEN08

**PNP CONTACT (M8 CONNECTOR)**

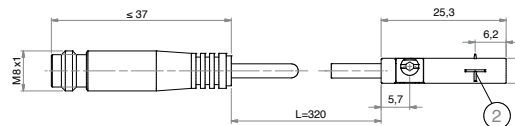

1= ECCENTRICO DI FISSAGGIO FASTENING CLAMP  
2= SUPERFICIE ATTIVA SENSING FACE

CABLAGGIO - WIRING

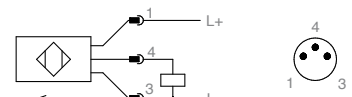

BN= MARRONE - BROWN  
BU= BLU - BLUE

**CONTATTO PNP (3 FILI)**

36.SEN09

36.SEN09.L6

36.SEN09.L10

**PNP CONTACT (3 WIRES)**

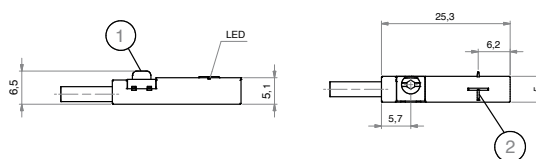

1= ECCENTRICO DI FISSAGGIO - FASTENING CLAMP  
2= SUPERFICIE ATTIVA - SENSING FACE

CABLAGGIO - WIRING

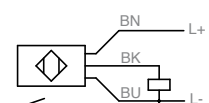

BK= NERO - BLACK  
BN= MARRONE - BROWN  
BU= BLU - BLUE

**CAVO PROLUNGA (CONNETTORE M8)**

*EXTENSION CABLE (M8 CONNECTOR)*

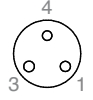
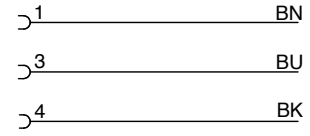
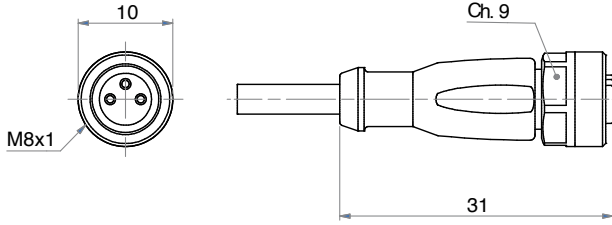

## SENSORI MAGNETICI (versione E CAVA C)

### MAGNETIC SENSORS (E version C-SLOT)

CARATTERISTICHE - CHARACTERISTICS					
CODICE - CODE		36.SEN26	36.SEN27	36.SEN28	36.SEN29
TIPO - TYPE		ELETTRONICO ELECTRONIC	ELETTRONICO ELECTRONIC	ELETTRONICO ELECTRONIC	ELETTRONICO ELECTRONIC
Modello elettrico - Electrical design		DC PNP	DC PNP	DC PNP	DC PNP
Funzione dell'uscita - Output		NO	NO	NO	NO
Tensione di esercizio - Operating voltage	[V]	10...30 DC	10...30 DC	10...30 DC	10...30 DC
Capacità di corrente - Current rating	[mA]	100	100	100	100
Sensibilità di reazione - Magnetic sensitivity	[mT]	2,8	2,8	2,8	2,8
Velocità di passaggio - Travel speed	[m/s]	> 10	> 10	> 10	> 10
Protezione da cortocircuito - Short-circuit proof		si - yes	si - yes	si - yes	si - yes
Protetto da inversione di polarità Reverse polarity protection		si - yes	si - yes	si - yes	si - yes
Resistente a sovraccarico - Overload protection		si - yes	si - yes	si - yes	si - yes
Caduta di tensione - Voltage drop	[V]	< 4,5	< 4,5	< 2,5	< 2,5
Isteresi - Hysteresis		< 0,12	< 0,12	< 1,5	< 1,5
Riproducibilità - Repeatability	[mm]	< 0,2	< 0,2	< 0,2	< 0,2
Corrente assorbita - Current consumption	[mA]	< 10	< 10	< 10	< 10
Frequenza di commutazione - Switching frequency	[Hz]	4.000	4.000	10.000	10.000
Temperatura ambiente - Ambient temperature	[°C]	-25...85	-25...85	-25...85	-25...85
Grado/Classe di protezione - Protection		IP65; IP67	IP65; IP67	IP65; IP67	IP65; IP67
Materiale involucro - Housing material		PA (poliammide - polyamide)			
Materiale eccentrico di fissaggio - Fastening clamp		inox - stainless steel			
Indicazione della funzione Stato di commutazione Function display Switching status	LED	giallo - yellow			
Collegamento - Connection		cavo PUR PUR cable / 2 m 2x0,14 mm <sup>2</sup>	cavo PUR PUR cable / 0,3 m spina M8 m8 connector	cavo PUR PUR cable / 0,3 m spina M8 m8 connector	cavo PUR PUR cable / 2 m 3x0,14 mm <sup>2</sup>
Peso - Weight	[g]	19	9,8	9,7	17,6

SERIE  
**E**

## ADATTATORE DA CAVA T A CAVA C

36.ADATC

### T-SLOT ADAPTER FOR C-SLOT

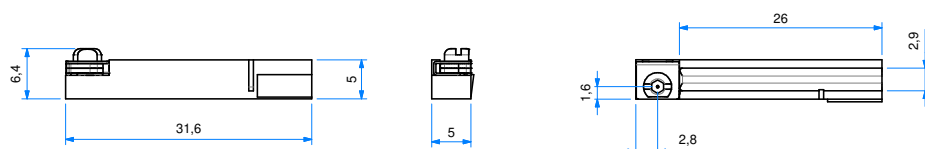

MATERIALE:  
ZINCO PRESSOFUSO;  
BRIGLIA DI FISSAGGIO: ACCIAIO INOX  
MATERIAL:  
DIECAST ZINC;  
FIXING ELEMENT: STAINLESS STEEL

**CONTATTO PNP (2 FILI)**

**PNP CONTACT (2 WIRES)**

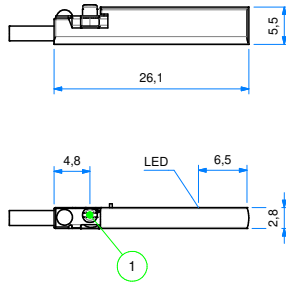

1= ECCENTRICO DI FISSAGGIO - FASTENING CLAMP

CABLAGGIO - WIRING

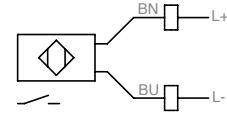

BN= MARRONE - BROWN  
BU= BLU - BLUE

SERIE

**E**

**CONTATTO PNP (CONNETTORE M8)**

**PNP CONTACT (M8 CONNECTOR)**

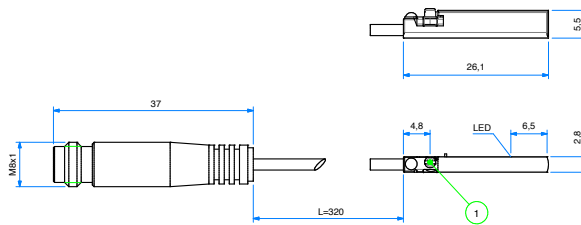

1= ECCENTRICO DI FISSAGGIO - FASTENING CLAMP

CABLAGGIO - WIRING

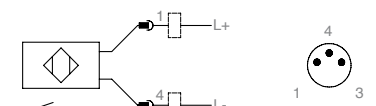

BN= MARRONE - BROWN  
BU= BLU - BLUE

**CONTATTO PNP (CONNETTORE M8)**

**PNP CONTACT (M8 CONNECTOR)**

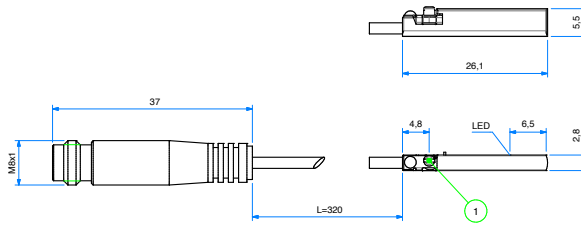

1= ECCENTRICO DI FISSAGGIO - FASTENING CLAMP

CABLAGGIO - WIRING

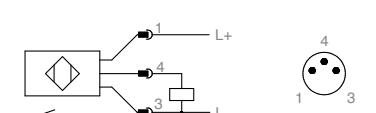

BN= MARRONE - BROWN  
BU= BLU - BLUE

**CONTATTO PNP (3 FILI)**

**PNP CONTACT (3 WIRES)**

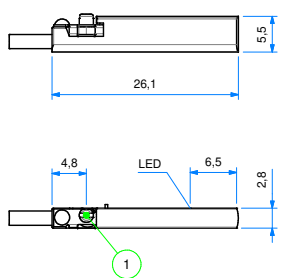

1= ECCENTRICO DI FISSAGGIO - FASTENING CLAMP

CABLAGGIO - WIRING

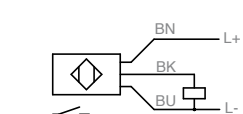

BK= NERO - BLACK  
BN= MARRONE - BROWN  
BU= BLU - BLUE





## SENSORI MAGNETICI ATEX

### ATEX MAGNETIC SENSORS

CARATTERISTICHE - CHARACTERISTICS	36.SEN32A.L6	36.SEN33A
TIPO - TYPE	ELETTRONICO - ELECTRONIC	ELETTRONICO - ELECTRONIC
Modello elettrico - Electrical design	DC PNP	DC PNP
Funzione dell'uscita - Output	NO	NO
Tensione di esercizio - Operating voltage	[V] 10...30 DC	10...30 DC
Capacità di corrente - Current rating	[mA] 100	100
Sensibilità di reazione - Magnetic sensitivity	[mT] 2	2,8
Velocità di passaggio - Travel speed	[m/s] > 10	> 10
Protezione da cortocircuito - Short-circuit proof	si - yes	si - yes
Protetto da inversione di polarità - Reverse polarity protection	si - yes	si - yes
Resistente a sovraccarico - Overload protection	si - yes	si - yes
Caduta di tensione - Voltage drop	[V] < 2,5	< 2,5
Isteresi - Hysteresis	1	< 1,5
Riproducibilità - Repeatability	[mm] < 0,2	< 0,2
Corrente assorbita - Current consumption	[mA] < 10	< 10
Ritardo alla disponibilità - Power-on delay time	[ms] < 30	< 30
Frequenza di commutazione - Switching frequency	[Hz] 6.000	10.000
Temperatura ambiente - Ambient temperature	[°C] -20...60	-25...60
Grado/Classe di protezione - Protection	IP 65/IP 67	IP 65/IP 67
Contrassegno - Marking of the unit	II 3D Ex tc IIIC T125°C Dc X II 3G Ex nA IIC T4 Gc X	II 3D Ex tc IIIC T125°C Dc X
Materiale involucro - Housing material	PA (poliammide-polyamide)	PA (poliammide-polyamide)
Materiale eccentrico di fissaggio - Fastening clamp	inox - stainless steel	inox - stainless steel
Indicazione della funzione Stato di commutazione Function display Switching status	LED giallo - yellow	giallo - yellow
Collegamento - Connection	cavo PVC - PVC cable 3x0,14 mm <sup>2</sup>	cavo PVC - PVC cable connettore M12 - M12 connector
Lunghezza cavo - Cable length	6 m	0,3 m
Peso - Weight	[g] 103,3	52,4

Accessori inclusi - Accessories included: Segnaposto in gomma, fascetta fermacavo - Rubber placeholder, cable clip

SERIE

E



36.SEN32A.L6

**CONTATTO PNP (3 FILI)**

**PNP CONTACT (3 WIRES)**

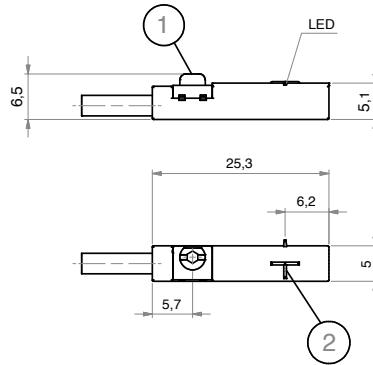

1= ECCENTRICO DI FISSAGGIO - FASTENING CLAMP  
2= SUPERFICIE ATTIVA - SENSING FACE

**CABLAGGIO - WIRING**

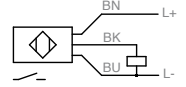

BK= NERO - BLACK  
BN= MARRONE - BROWN  
BU= BLU - BLUE



36.SEN33A

**CONTATTO PNP (CONNETTORE M12)**

**PNP CONTACT (M12 CONNECTOR)**

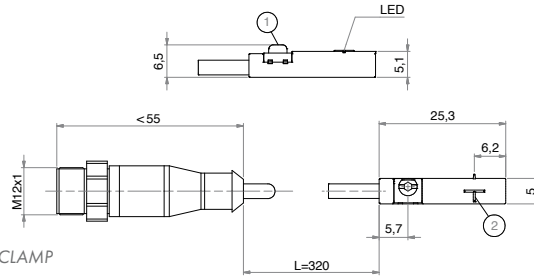

1= ECCENTRICO DI FISSAGGIO - FASTENING CLAMP  
2= SUPERFICIE ATTIVA - SENSING FACE

**CABLAGGIO - WIRING**

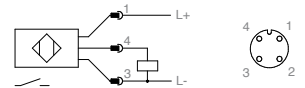

BK= NERO - BLACK  
BN= MARRONE - BROWN  
BU= BLU - BLUE



36.CAVA

**CAVO PROLUNGA (CONNETTORE M12)**

**EXTENSION CABLE (M12 CONNECTOR)**

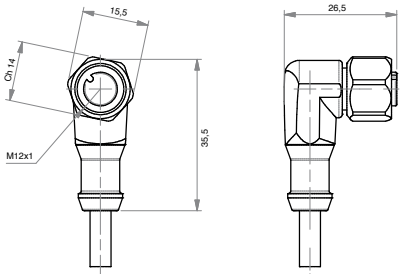

**CABLAGGIO - WIRING**

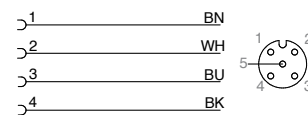

BK= NERO - BLACK  
BN= MARRONE - BROWN  
BU= BLU - BLUE  
WH= BIANCO - WHITE

<b>DIMENSIONI - DIMENSIONS</b>		<b>36.CAV5A.M12</b>	<b>36.CAV10A.M12</b>
<b>Modello elettrico - Electrical design</b>		AC/DC	AC/DC
<b>Tensione di esercizio - Operating voltage</b>	[V]	60 AC / 60 DC	60 AC / 60 DC
<b>Capacità di corrente - Current rating</b>	[A]	2	2
<b>Modello - Design</b>		ad angolo - angled	ad angolo - angled
<b>Temperatura ambiente - Ambient temperature</b>	[°C]	-20...60	-20...60
<b>Grado/Classe di protezione - Protection</b>		IP67/IP68 - IP69K fuori dalla zona esplosiva - outside hazardous areas	
<b>Contrassegno - Marking of the unit</b>		II 3G Ex nA IIC Gc - II 2D Ex tb IIIC Db IP65/IP67	
<b>Materiale corpo - Body material: Involucro - Housing</b>		TPU arancione - orange TPU	TPU arancione - orange TPU
<b>Guarnizione - Sealing</b>		viton	viton
<b>Materiale dado - Nut material</b>		inox - stainless steel (1.4404 / 316L)	inox - stainless steel (1.4404 / 316L)
<b>Coppia di serraggio per nodo nocciolo - Tightening torque for knurled nut</b>	[Nm]	0,2...1,5	0,2...1,5
<b>Collegamento - Connection</b>		cavo PUR - PUR cable / 5 m; 4 x 0,34 mm <sup>2</sup> (42 x Ø 0,1 mm); Ø 4,9 mm; senza alogeno - alogen free	cavo PUR - PUR cable / 10 m; 4 x 0,34 mm <sup>2</sup> (42 x Ø 0,1 mm); Ø 4,9 mm; senza alogeno - alogen free
<b>Colore della guaina - Sheath colour</b>		nero - black	nero - black

AIR

THE BEST WAY TO



ARTEC SRL Via B. Zallone, 24

44042 CENTO (FE) - ITALY

☎ +39 051 683 62 20

☎ +39 051 683 08 82

✉ info@artec-pneumatic.com

🌐 www.artec-pneumatic.com



AZIENDA CON SISTEMA  
DI GESTIONE QUALITÀ  
CERTIFICATO ISO 9001:2015

PARTNER IN THE U.S.A & CANADA



W.C. Branham, Inc.

398 Troy Street

River Falls, WI 54022

☎ 800-428-1974 (Toll-free US & Canada)

715-426-2000 (Main)

☎ 715-426-1400

✉ AskWCB@wcbranham.com

🌐 www.wcbranham.com