



SERIE



MINICILINDRI ISO 6432
ISO 6432 MICRO CYLINDERS

ARTEC[®]
PNEUMATIC COMPONENTS

 **WC
BRANHAM**[®]
SOLUTIONS IN MOTION

CARATTERISTICHE TECNICHE - TECHNICAL CHARACTERISTICS

Pressione di esercizio <i>Working pressure</i>	1 ÷ 10 bar
Temperatura di esercizio <i>Working temperature</i>	0 ÷ +80°C (-20°C con aria secca - <i>with dry air</i>) 0 ÷ +150°C (con guarnizioni per alte temperature - <i>with high temperature seals</i>)
Versioni - Versions	semplice effetto, doppio effetto, stelo passante - <i>single acting, double acting, double rod</i>
Alesaggi - Bores	Ø 8 - 10 - 12 - 16 - 20 - 25 (conformi alla norma ISO 6432 - <i>in accordance with ISO 6432</i>)
Corse - Strokes	vedere tabelle corse standard - <i>see standard stroke tables</i>
Fluidi - Fluid	aria compressa filtrata, non lubrificata - <i>compressed filtered, non lubricated air</i>

CARATTERISTICHE COSTRUTTIVE - CONSTRUCTIVE CHARACTERISTICS

①	Stelo - Rod	Ø 8÷25 acciaio inox AISI 303 - <i>AISI 303 stainless steel</i>
② ⑤	Dado - Nut	acciaio zincato - <i>zinc coated steel</i>
③	Guarnizione stelo - Rod seal	poliuretano - <i>polyurethane</i>
④	Boccola - Bush	bronzo sinterizzato - <i>sintered bronze</i>
⑥ ⑫	Testate - Covers	alluminio anodizzato - <i>anodized aluminium</i>
⑦	Paracolpo - Bumper	neoprene
⑧	Tubo - Tube	acciaio inox AISI 304 - <i>AISI 304 stainless steel</i>
⑨	Magnete - Magnet	plastroferrite - <i>rubber magnet</i>
⑩	Guarnizioni pistone - Piston seals	poliuretano - <i>polyurethane</i>
⑪	Pistone - Piston	Ø 8 - 10 - 12 ottone - <i>brass</i> Ø 16 - 20 - 25 alluminio - <i>aluminium</i>

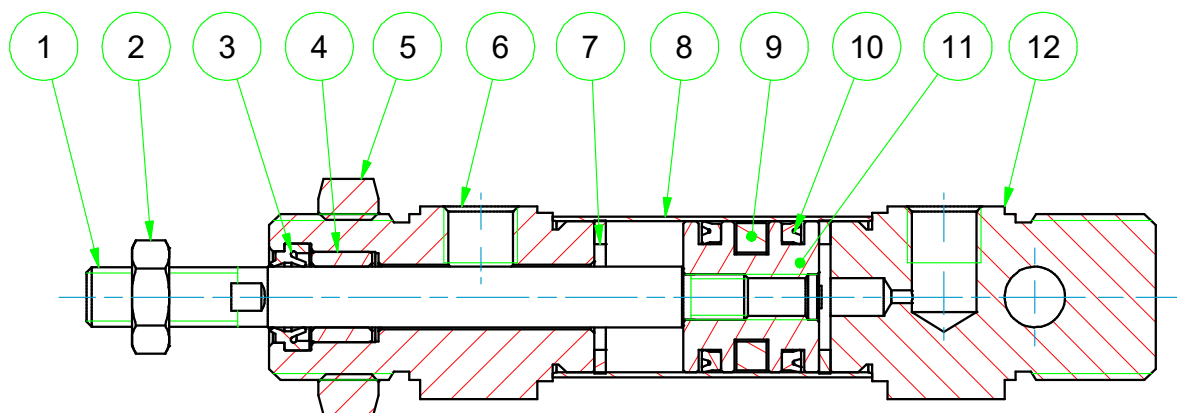

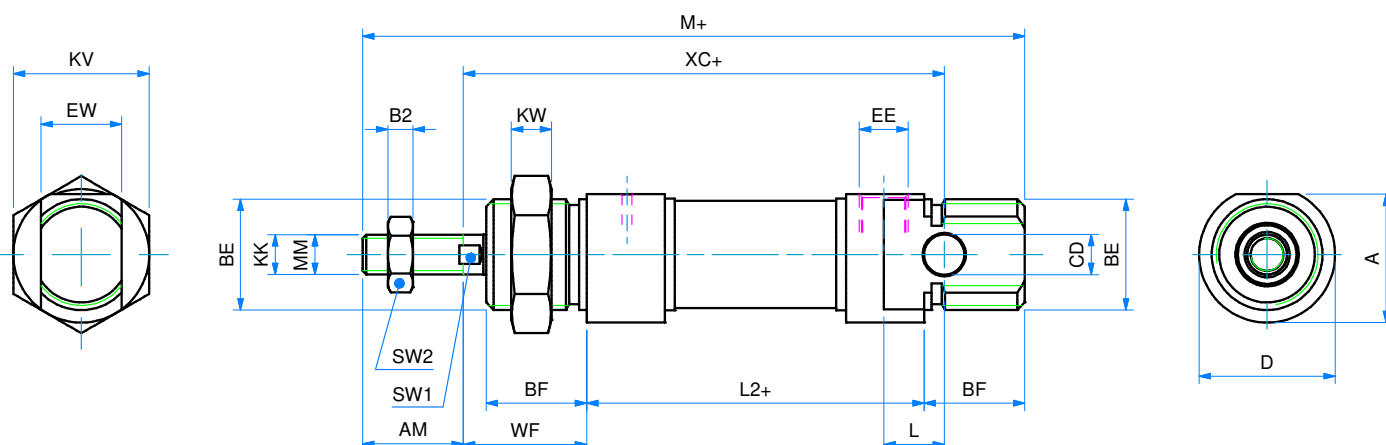
SEMPLICE EFFETTO MAGNETICO - MOLLA ANTERIORE
SINGLE ACTING MAGNETIC - FRONT SPRING

Note: OSM realizzato con una guarnizione pistone e senza guarnizione stelo
 Note: OSM made with one piston seal and without rod seal

Note: dado stelo e dado testa compresi nella fornitura
 Note: rod nut and nose nut included in the supply

DIMENSIONI - DIMENSIONS

ø	8	10	12	16	20	25
A	15	15	18	18	25.5	28.5
AM	12	12	16	16	20	22
B2	4	4	4	4	5	6
BE	M12x1.25	M12x1,25	M16x1,5	M16x1,5	M22x1.5	M22x1.5
BF	12	12	18	18	20	22
CD	4	4	6	6	8	8
ø D	16	16	19	19	27	30
EE	M5	M5	M5	M5	1/8G	1/8G
EW	8	8	12	12	16	16
KK	M4	M4	M6	M6	M8	M10x1.25
KV	19	19	22	22	27	27
KW	7	7	6	6	8	8
L	6	6	9	9	12	12
L2+	46	46	48	53	67	68
M+	86	86	104	109	131	140
ø MM	4	4	6	6	8	10
SW1	-	-	5	5	7	9
SW2	7	7	10	10	13	17
WF	16	16	22	22	24	28
XC+	64	64	75	82	95	104

ø CORSE STANDARD - STANDARD STROKES

ø 008	10 - 25 - 50
ø 010	10 - 25 - 50
ø 012	10 - 25 - 50
ø 016	10 - 25 - 50
ø 020	10 - 25 - 50
ø 025	10 - 25 - 50

+ = lunghezza corsa - stroke length

SEMPLICE EFFETTO MAGNETICO - MOLLA POSTERIORE

OSEM
ø 16 ÷ 25

SINGLE ACTING MAGNETIC - REAR SPRING

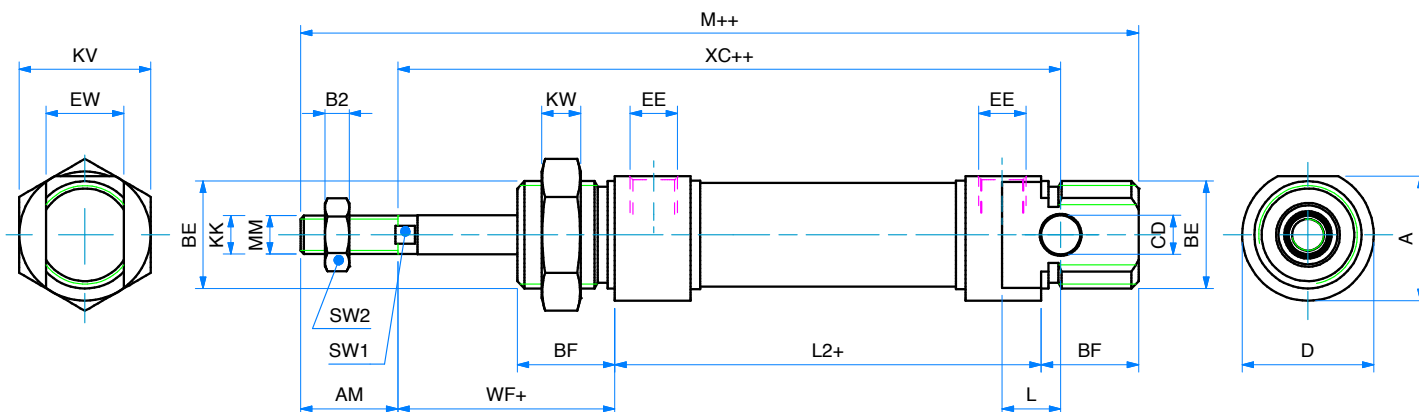
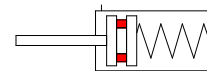

Note: OSM realizzato con una guarnizione pistone

Note: OSM made with one piston seal

Note: dado stelo e dado testa compresi nella fornitura

Note: rod nut and nose nut included in the supply

DIMENSIONI - DIMENSIONS			
ø	16	20	25
A	18	25,5	28,5
AM	16	20	22
B2	4	5	6
BE	M16x1.5	M22x1.5	M22x1.5
BF	18	20	22
CD	6	8	8
ø D	19	27	30
EE	M5	1/8G	1/8G
EW	12	16	16
KK	M6	M8	M10x1.25
KV	22	27	27
KW	6	8	8
L	9	12	12
L2+	78,5	90	94
M++	134,5	154	166
ø MM	6	8	10
SW1	5	7	9
SW2	10	13	17
WF+	22	24	28
XC++	107,5	118	130

ø	CORSE STANDARD - STANDARD STROKES		
016	10	25	50
020	10	25	50
025	10	25	50

+ = lunghezza corsa - stroke length

++ = 2 x lunghezza corsa - 2 x stroke length

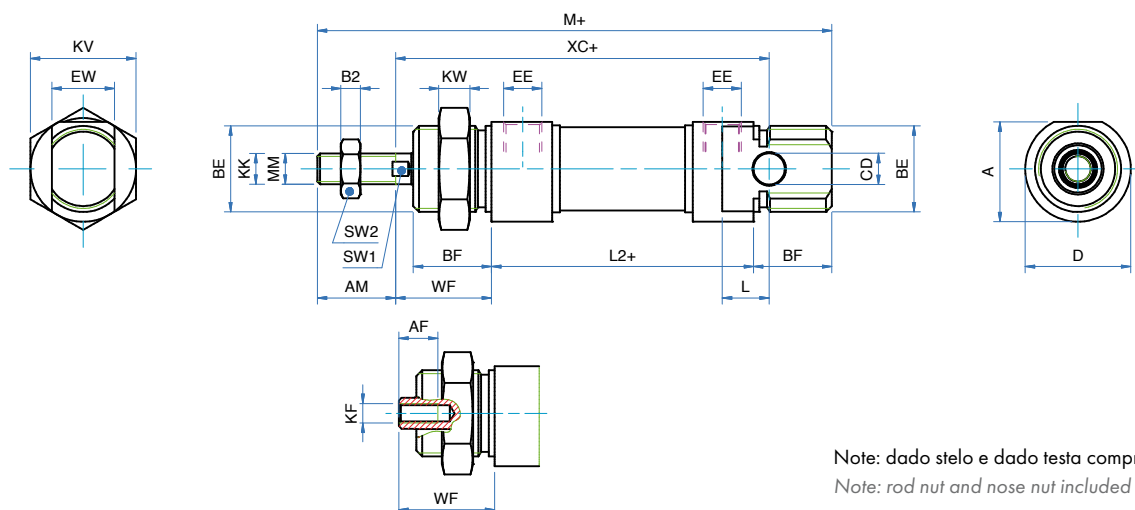
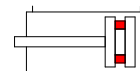
DOPPIO EFFETTO MAGNETICO
DOUBLE ACTING MAGNETIC

Note: dado stelo e dado testa compresi nella fornitura
 Note: rod nut and nose nut included in the supply

DIMENSIONI - DIMENSIONS

ø	8	10	12	16	20	25
A	15	15	18	18	25.5	28.5
AF	-	-	-	-	12	12
AM	12	12	16	16	20	22
B2	4	4	4	4	5	6
BE	M12x1.25	M12x1.25	M16x1.5	M16x1.5	M22x1.5	M22x1.5
BF	12	12	18	18	20	22
CD	4	4	6	6	8	8
ø D	16	16	19	19	27	30
EE	M5	M5	M5	M5	1/8G	1/8G
EW	8	8	12	12	16	16
KF	-	-	-	-	M4	M6
KK	M4	M4	M6	M6	M8	M10x1.25
KV	19	19	22	22	27	27
KW	7	7	6	6	8	8
L	6	6	9	9	12	12
L2+	46	46	48	53	67	68
M+	86	86	104	109	131	140
ø MM	4	4	6	6	8	10
SW1	-	-	5	5	7	9
SW2	7	7	10	10	13	17
WF	16	16	22	22	24	28
XC+	64	64	75	82	95	104

+ = lunghezza corsa - stroke length

ø CORSE STANDARD - STANDARD STROKES

008 10 - 25 - 50 - 80 - 100 - 125

010 10 - 25 - 50 - 80 - 100 - 125

012 10 - 25 - 50 - 80 - 100 - 125 - 160 - 200 - 250 - 320 - 400 - 500

016 10 - 25 - 50 - 80 - 100 - 125 - 160 - 200 - 250 - 320 - 400 - 500 - 600 - 700 - 800 - 900 - 1000

020 10 - 25 - 50 - 80 - 100 - 125 - 160 - 200 - 250 - 320 - 400 - 500 - 600 - 700 - 800 - 900 - 1000

025 10 - 25 - 50 - 80 - 100 - 125 - 160 - 200 - 250 - 320 - 400 - 500 - 600 - 700 - 800 - 900 - 1000

ODM-T1
ø 16 ÷ 25

DOPPIO EFFETTO MAGNETICO TESTA CORTA ALIMENTAZIONE 90°

DOUBLE ACTING MAGNETIC SHORT HEAD CONNECTION AT 90°

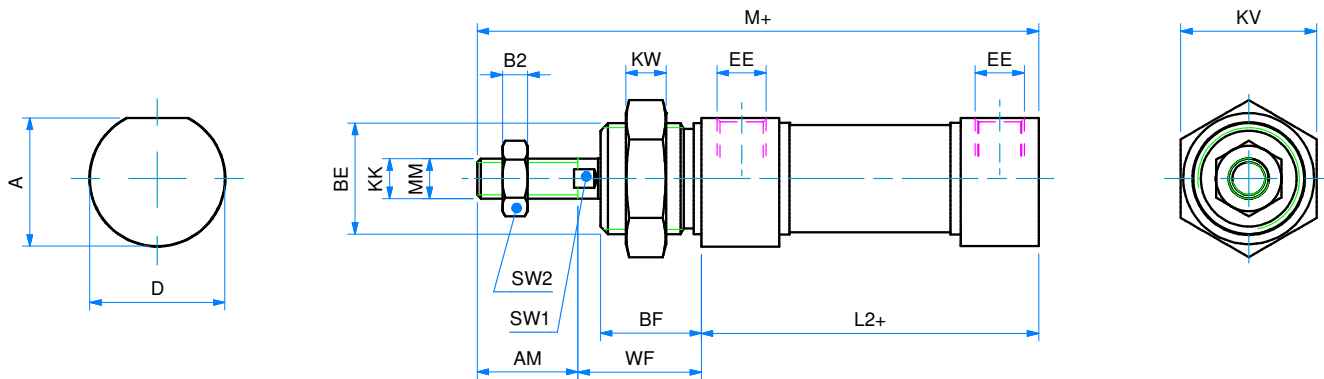
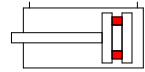

Note: dado stelo e dado testa compresi nella fornitura
Note: rod nut and nose nut included in the supply

DIMENSIONI - DIMENSIONS			
ø	16	20	25
A	18	25,5	28,5
AM	16	20	22
B2	4	5	6
BE	M16x1.5	M22x1.5	M22x1.5
BF	18	20	22
ø D	19	27	30
EE	M5	1/8G	1/8G
KK	M6	M8	M10x1.25
KV	22	27	27
KW	6	8	8
L2+	53	67	68
M+	91	111	118
ø MM	6	8	10
SW1	5	7	9
SW2	10	13	17
WF	22	24	28

+ = lunghezza corsa - stroke length

ø	CORSE STANDARD - STANDARD STROKES																
016	10	25	50	80	100	125	160	200	250	320	400	500	600	700	800	900	1000
020	10	25	50	80	100	125	160	200	250	320	400	500	600	700	800	900	1000
025	10	25	50	80	100	125	160	200	250	320	400	500	600	700	800	900	1000

DOPPIO EFFETTO MAGNETICO TESTATA CORTA ALIMENTAZIONE IN ASSE

DOUBLE ACTING MAGNETIC SHORT HEAD CONNECTION ON AXIS

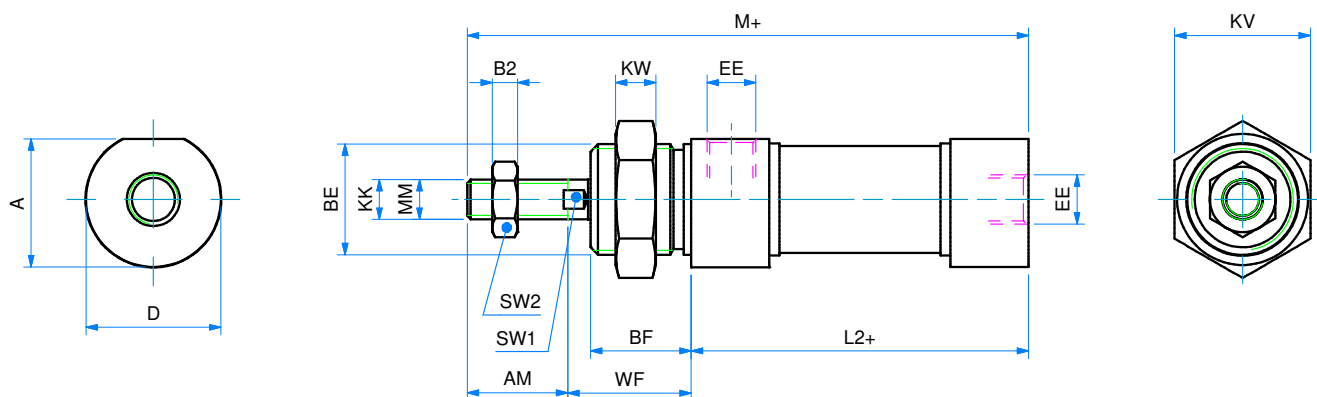
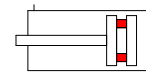

Note: dado stelo e dado testa compresi nella fornitura
 Note: rod nut and nose nut included in the supply

DIMENSIONI - DIMENSIONS

ø	16	20	25
A	18	25,5	28,5
AM	16	20	22
B2	4	5	6
BE	M16x1.5	M22x1.5	M22x1.5
BF	18	20	22
ø D	19	27	30
EE	M5	1/8G	1/8G
KK	M6	M8	M10x1.25
KV	22	27	27
KW	6	8	8
L2+	53	67	68
M+	91	111	118
ø MM	6	8	10
SW1	5	7	9
SW2	10	13	17
WF	22	24	28

+ = lunghezza corsa - stroke length

ø CORSE STANDARD - STANDARD STROKES

016	10 - 25 - 50 - 80 - 100 - 125 - 160 - 200 - 250 - 320 - 400 - 500 - 600 - 700 - 800 - 900 - 1000
020	10 - 25 - 50 - 80 - 100 - 125 - 160 - 200 - 250 - 320 - 400 - 500 - 600 - 700 - 800 - 900 - 1000
025	10 - 25 - 50 - 80 - 100 - 125 - 160 - 200 - 250 - 320 - 400 - 500 - 600 - 700 - 800 - 900 - 1000

DOPPIO EFFETTO MAGNETICO AMMORTIZZATO

DOUBLE ACTING MAGNETIC CUSHIONED

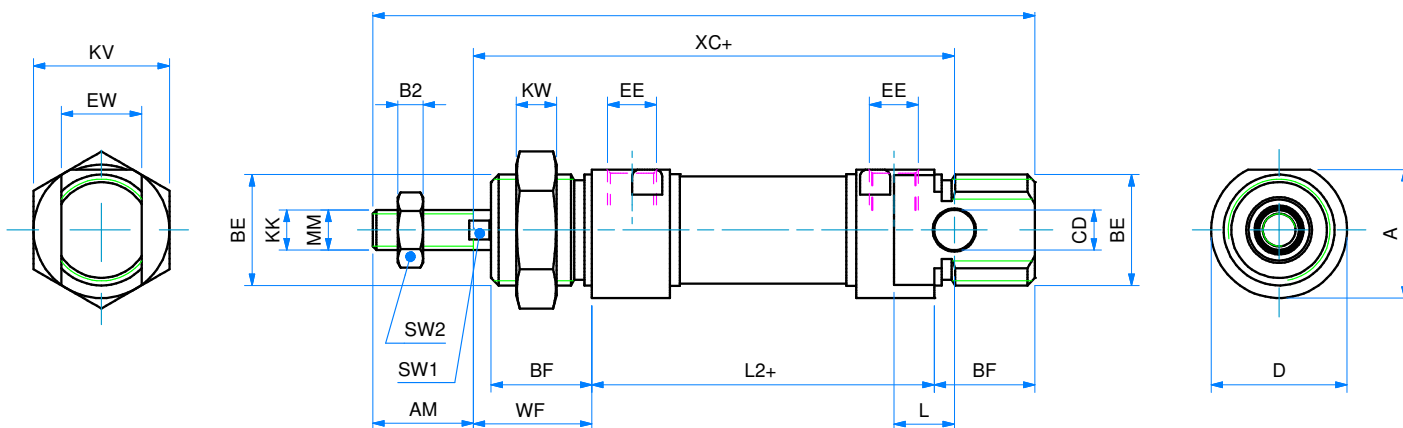

Note: dado stelo e dado testa compresi nella fornitura
Note: rod nut and nose nut included in the supply

DIMENSIONI - DIMENSIONS			
ø	16	20	25
A	20	25,5	28,5
AM	16	20	22
B2	4	5	6
BE	M16x1.5	M22x1.5	M22x1.5
BF	18	20	22
CD	6	8	8
ø D	21	27	30
EE	M5	1/8G	1/8G
EW	12	16	16
KK	M6	M8	M10x1.25
KV	22	27	27
KW	6	8	8
L	9	12	12
L2+	53	67	68
M+	109	131	140
ø MM	6	8	10
SW1	5	7	9
SW2	10	13	17
WF	22	24	28
XC+	82	95	104

+ = lunghezza corsa - stroke length

ø	CORSE STANDARD - STANDARD STROKES
016	10 - 25 - 50 - 80 - 100 - 125 - 160 - 200 - 250 - 320 - 400 - 500 - 600 - 700 - 800 - 900 - 1000
020	10 - 25 - 50 - 80 - 100 - 125 - 160 - 200 - 250 - 320 - 400 - 500 - 600 - 700 - 800 - 900 - 1000
025	10 - 25 - 50 - 80 - 100 - 125 - 160 - 200 - 250 - 320 - 400 - 500 - 600 - 700 - 800 - 900 - 1000

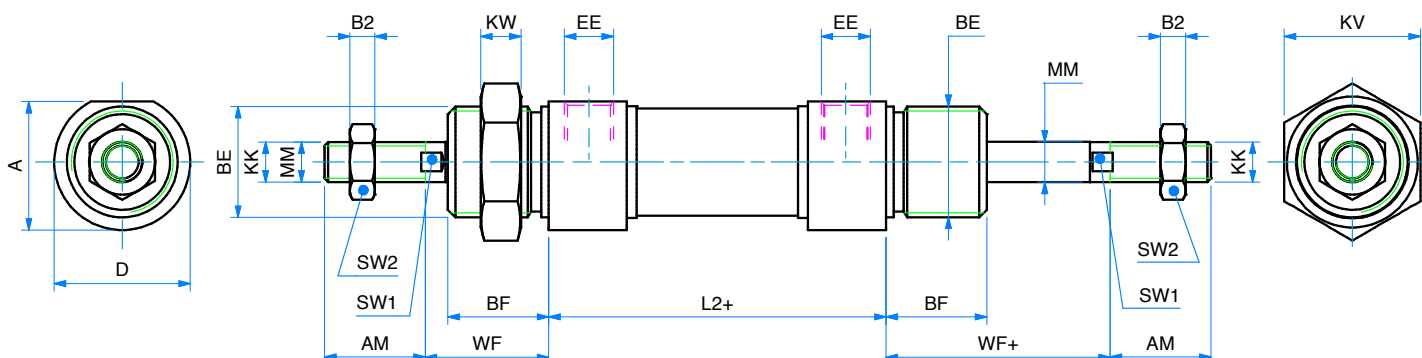
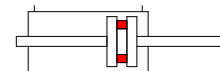
DOPPIO EFFETTO MAGNETICO STELO PASSANTE
DOUBLE ACTING MAGNETIC WITH DOUBLE ROD

Note: dado stelo e dado testa compresi nella fornitura
 Note: rod nut and nose nut included in the supply

DIMENSIONI - DIMENSIONS

ø	12	16	20	25
A	18	18	25,5	28,5
AM	16	16	20	22
B2	4	4	5	6
BE	M16x1.5	M16x1.5	M22x1.5	M22x1.5
BF	18	18	20	22
ø D	19	19	27	30
EE	M5	M5	1/8G	1/8G
KK	M6	M6	M8	M10x1.25
KV	22	22	27	27
KW	6	6	8	8
L2+	48	53	67	68
ø MM	6	6	8	10
SW1	5	5	7	9
SW2	10	10	13	17
WF	22	22	24	28
WF+	22	22	24	28

+ = lunghezza corsa - stroke length

ø CORSE STANDARD - STANDARD STROKES

016 10 - 25 - 50 - 80 - 100 - 125 - 160 - 200 - 250 - 320 - 400 - 500 - 600 - 700 - 800 - 900 - 1000

020 10 - 25 - 50 - 80 - 100 - 125 - 160 - 200 - 250 - 320 - 400 - 500 - 600 - 700 - 800 - 900 - 1000

025 10 - 25 - 50 - 80 - 100 - 125 - 160 - 200 - 250 - 320 - 400 - 500 - 600 - 700 - 800 - 900 - 1000

DOPPIO EFFETTO MAGNETICO STELO PASSANTE AMMORTIZZATO

ODMP-W
Ø 16 ÷ 25

DOUBLE ACTING MAGNETIC CUSHIONED WITH DOUBLE ROD

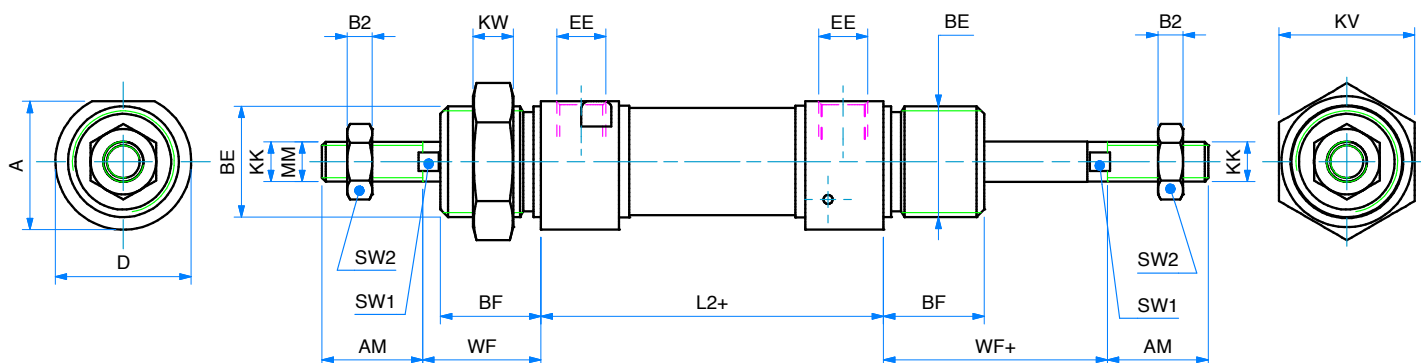
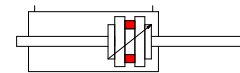

Note: dado stelo e dado testa compresi nella fornitura
Note: rod nut and nose nut included in the supply

DIMENSIONI - DIMENSIONS

Ø	16	20	25
A	20	25,5	28,5
AM	16	20	22
B2	4	5	6
BE	M16x1.5	M22x1.5	M22x1.5
BF	18	20	22
Ø D	21	27	30
EE	M5	1/8G	1/8G
KK	M6	M8	M10x1.25
KV	22	27	27
KW	6	8	8
L2+	53	67	68
Ø MM	6	8	10
SW1	5	7	9
SW2	10	13	17
WF	22	24	28
WF+	22	24	28

+ = lunghezza corsa - stroke length

Ø CORSE STANDARD - STANDARD STROKES

Ø16	10 - 25 - 50 - 80 - 100 - 125 - 160 - 200 - 250 - 320 - 400 - 500 - 600 - 700 - 800 - 900 - 1000
Ø20	10 - 25 - 50 - 80 - 100 - 125 - 160 - 200 - 250 - 320 - 400 - 500 - 600 - 700 - 800 - 900 - 1000
Ø25	10 - 25 - 50 - 80 - 100 - 125 - 160 - 200 - 250 - 320 - 400 - 500 - 600 - 700 - 800 - 900 - 1000

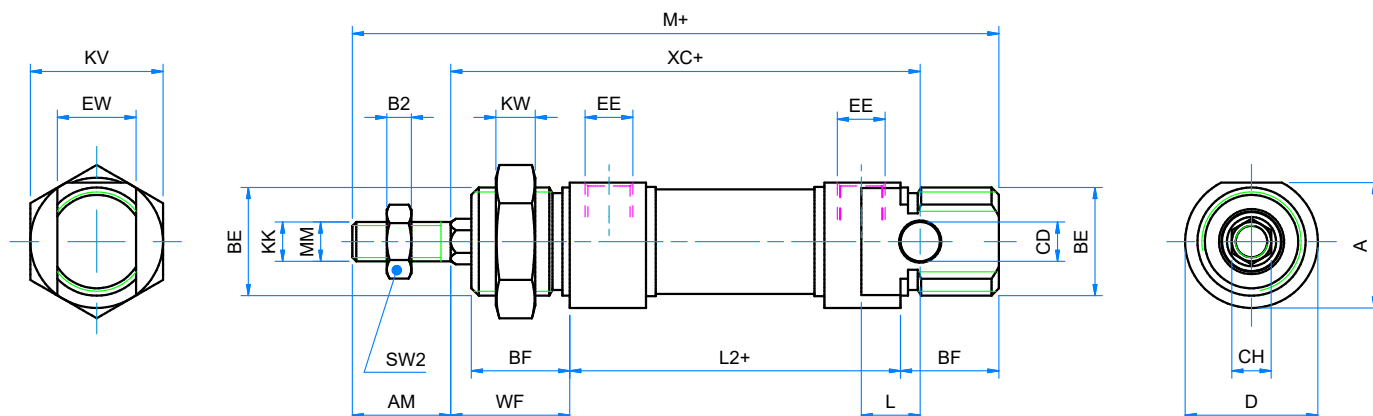
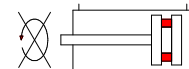
DOPPIO EFFETTO MAGNETICO ANTIROTAZIONE CON STELO ESAGONALE
DOUBLE ACTING MAGNETIC ANTI-ROTATION WITH HEXAGONAL ROD

Note: dado stelo e dado testa compresi nella fornitura
 Note: rod nut and nose nut included in the supply

DIMENSIONI - DIMENSIONS

ø	16	20	25
A	18	25,5	28,5
AM	16	20	22
B2	4	5	6
BE	M16x1,5	M22x1,5	M22x1,5
BF	18	20	22
ø CD	6	8	8
CH	6	8	10
ø D	19	27	30
EE	M5	G 1/8"	G 1/8"
EW	12	16	16
KK	M6	M8	M10x1,25
KV	22	27	27
KW	6	8	8
L	9	12	12
L2+	53	67	68
M+	109	131	140
SW2	10	13	17
WF	22	24	28
XC+	82	95	104

+ = lunghezza corsa - stroke length

ø CORSE STANDARD - STANDARD STROKES

016 10 - 25 - 50 - 80 - 100 - 125 - 160 - 200 - 250 - 320 - 400 - 500 - 600 - 700 - 800 - 900 - 1000

020 10 - 25 - 50 - 80 - 100 - 125 - 160 - 200 - 250 - 320 - 400 - 500 - 600 - 700 - 800 - 900 - 1000

025 10 - 25 - 50 - 80 - 100 - 125 - 160 - 200 - 250 - 320 - 400 - 500 - 600 - 700 - 800 - 900 - 1000

DOPPIO EFFETTO MAGNETICO CON STELO FORATO

DOUBLE ACTING MAGNETIC WITH HOLLOW ROD

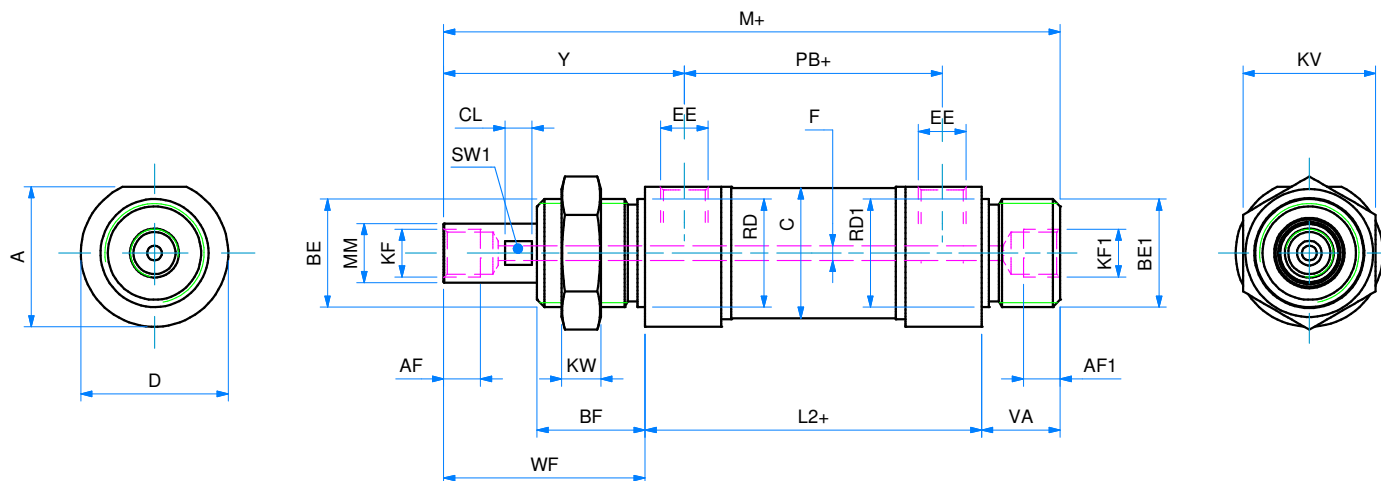

Note: stelo in C45 cromato

Note: C45 chromed rod

Note: dado testa compreso nella fornitura

Note: nose nut included in the supply

DIMENSIONI - DIMENSIONS

ø	25
A	28,5
AF	7,5
AF1	7,5
BE	M22x1,5
BE1	M22x1,5
BF	22
ø C	26,5
CL	5,5
ø D	30
EE	G 1/8"
F	3
KF	G 1/8"
KF1	G 1/8"
KV	27
KW	8
L2+	68
M+	125
ø MM	12
PB+	52
ø RD	22
ø RD1	22
SW1	11
VA	16
WF	41
Y	49

ø CORSE STANDARD - STANDARD STROKES

025	50 - 100 - 150 - 200 - 250 - 300 - 350
------------	--

+ = lunghezza corsa - stroke length

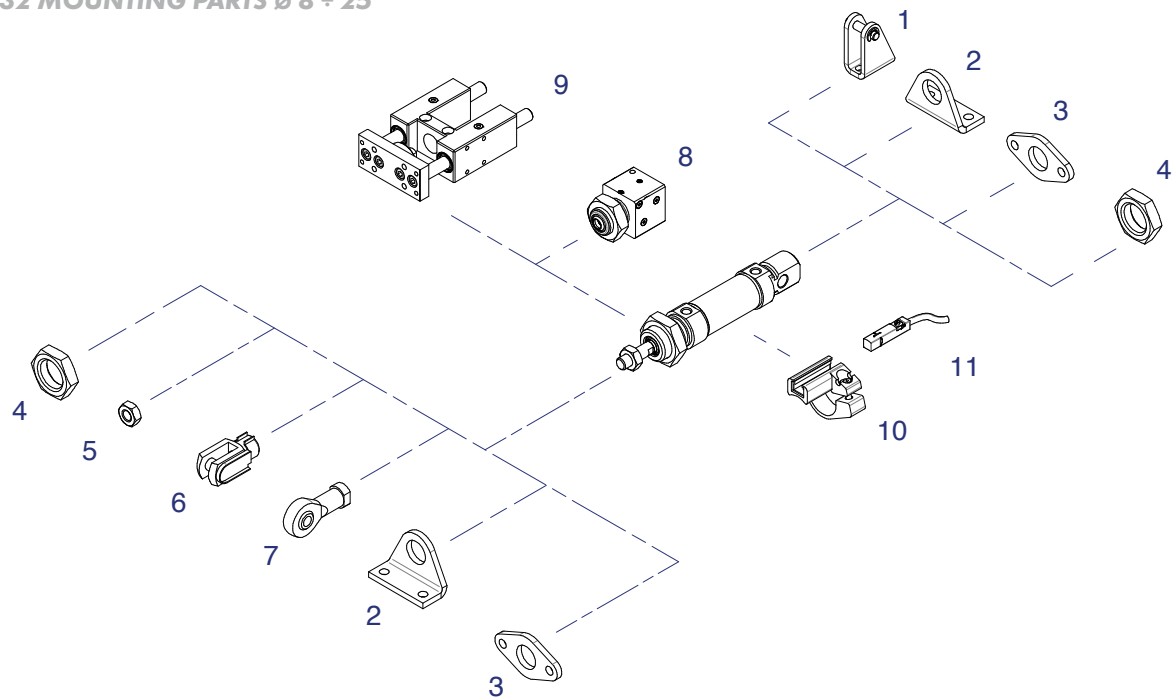
ACCESSORI DI FISSAGGIO ISO 6432 \varnothing 8 ÷ 25
ISO 6432 MOUNTING PARTS \varnothing 8 ÷ 25

POS.	CODE	DESCRIZIONE - DESCRIPTION
1	MCFI ---,---	cerniera con perno - female hinge with pin
2	MPBI ---,---	pedino - foot mounting
3	MFI ---,---	flangia - flange
4	DAT ---,---	dado testata - nose nut
5	DA --x---	dado stelo - rod nut
6	FC --x---	forcella con clips - clevis with lockable pin
7	SSFI --x---	snodo sferico - rod eye
8	BH ---	bloccastelo - rod lock
9	GU ---,---, / GH ---,---, -	unità di guida - guide unit
10	36.TIRM --	adattatore sensore - sensor mounting
11	36-SEN ---	sensore magnetico - magnetic sensor

UNITÀ DI GUIDA

GU

GH

GUIDE UNIT

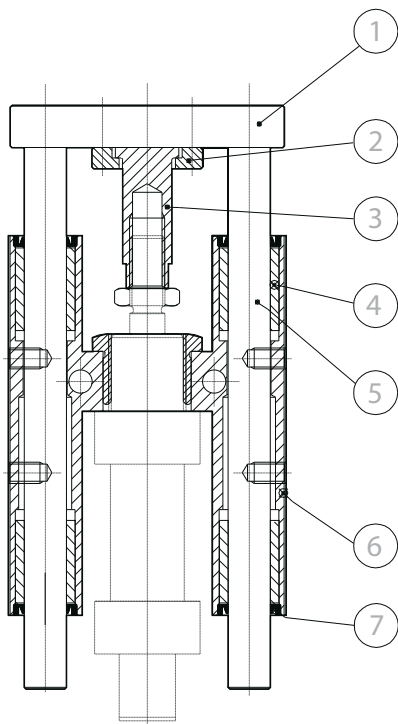

CARATTERISTICHE COSTRUTTIVE - CONSTRUCTIVE CHARACTERISTICS

①	Piastra - Plate	alluminio anodizzato - anodized aluminium
②	Ghiera - Slotted nut	acciaio zincato - zinc coated steel
③	Giunto - coupling	acciaio zincato - zinc coated steel
④	Boccola guida - Slide bearing	bronzo - bronze
⑤	Stelo - Rod	acciaio cromato - chromed steel
⑥	Corpo - Body	alluminio anodizzato - anodized aluminium
⑦	Raschiastelo - Scraper	NBR

CHIAVE DI CODIFICA

KEY CODE

G H X 0 2 5 . 1 0 0 . S

	ALESAGGIO - BORE (Ø)	CORSA - STROKE (mm)	GIUNTO - COUPLING
	016-020-025	050-100-160-200 250-320-400-500 600-700-800-900-1000	S giunto corto short coupling
VERSIONE - VERSION			L giunto lungo long coupling
H	tipo H con boccole in bronzo H type with bronze bushes		
HX	tipo H con boccole in bronzo e steli in acciaio inox AISI 304 H type with bronze bushes and AISI 304 SS rods		
HS	tipo H con cuscinetti a ricircolo di sfere e steli in acciaio cromato H type with recirculating ball bearings and chromed steel rods		
U	tipo U con boccole in bronzo U type with bronze bushes		
UX	tipo U con boccole in bronzo e steli in acciaio inox AISI 304 U type with bronze bushes and AISI 304 SS rods		

SERIE - SERIES

G unità di guida
guide unit



DIAGRAMMA CARICO AMMISSIBILE

ALLOWABLE LOAD



DIAGRAMMA CARICO AMMISSIBILE

ALLOWABLE LOAD

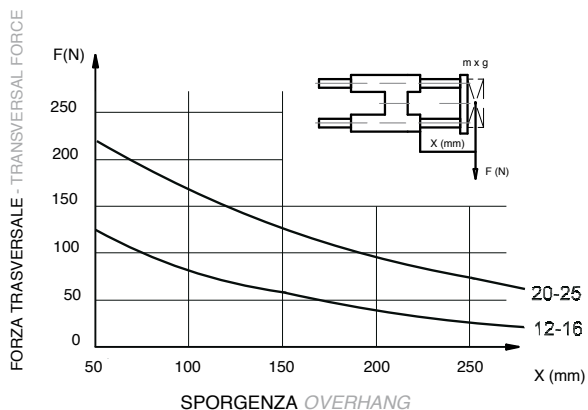
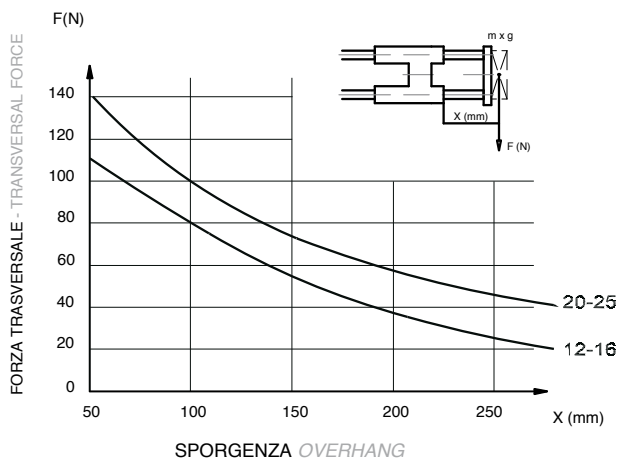

DIMENSIONI

DIMENSIONS

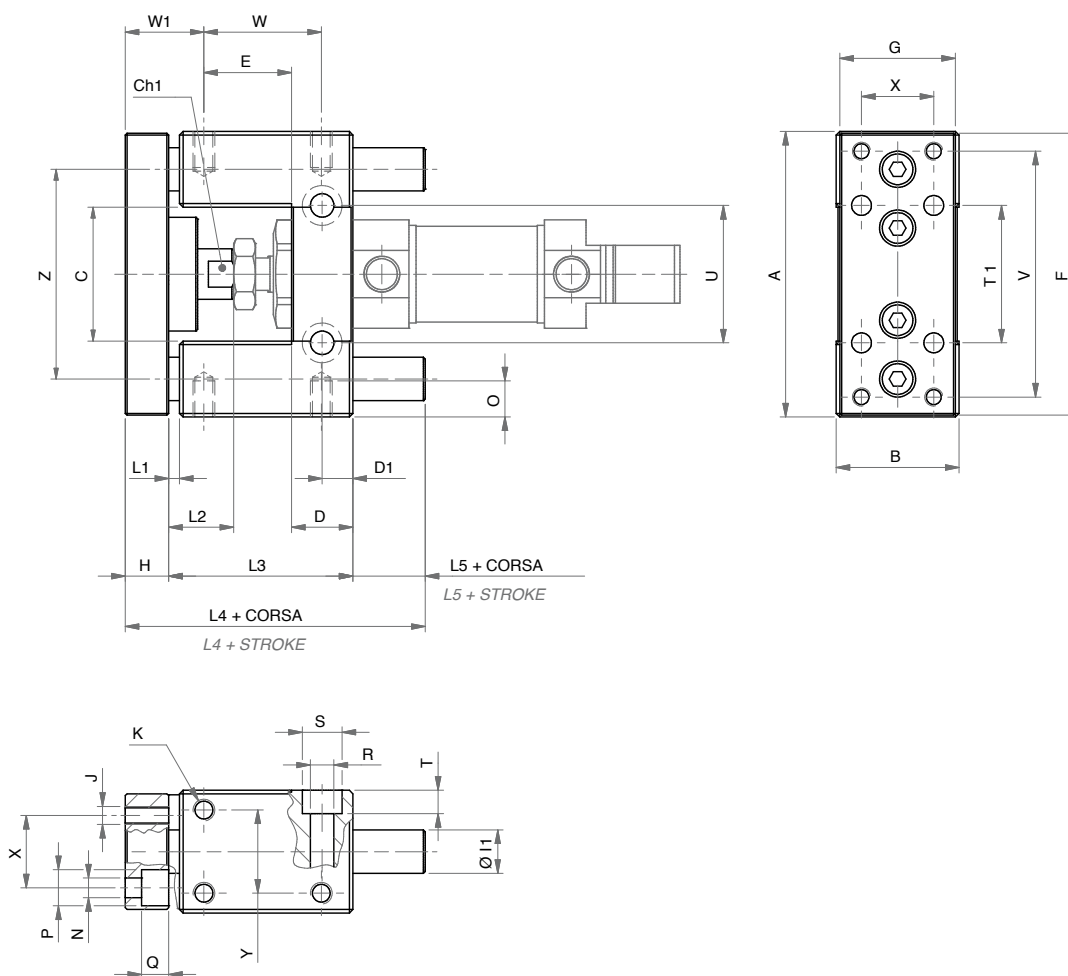

GIUNTO CORTO - SHORT COUPLING

ø	A	B	C	Ch1	D	D1	E	F	G	H	ø11	J	K	L1	L2	L3
12 - 16	69	30	30	8	12	6	19	66	29	10	10	M4	M4	3	18	38
20 - 25	79	34	37	12	17	8,5	24,25	78	32	12	12	M5	M6	3	18	48

ø	L4	L5	N	O	P	Q	R	S	T	T1	U	V	W	W1	X	Y	Z
12 - 16	66,5	15,5	4,5	6	8	4,5	5,5	9	5,5	32	24	58	25	20	18	22	49,5
20 - 25	83	20	5,5	9	10	7,5	6,5	11	6,5	38	38	68	32,5	21,75	20	23	58



DIMENSIONI

DIMENSIONS

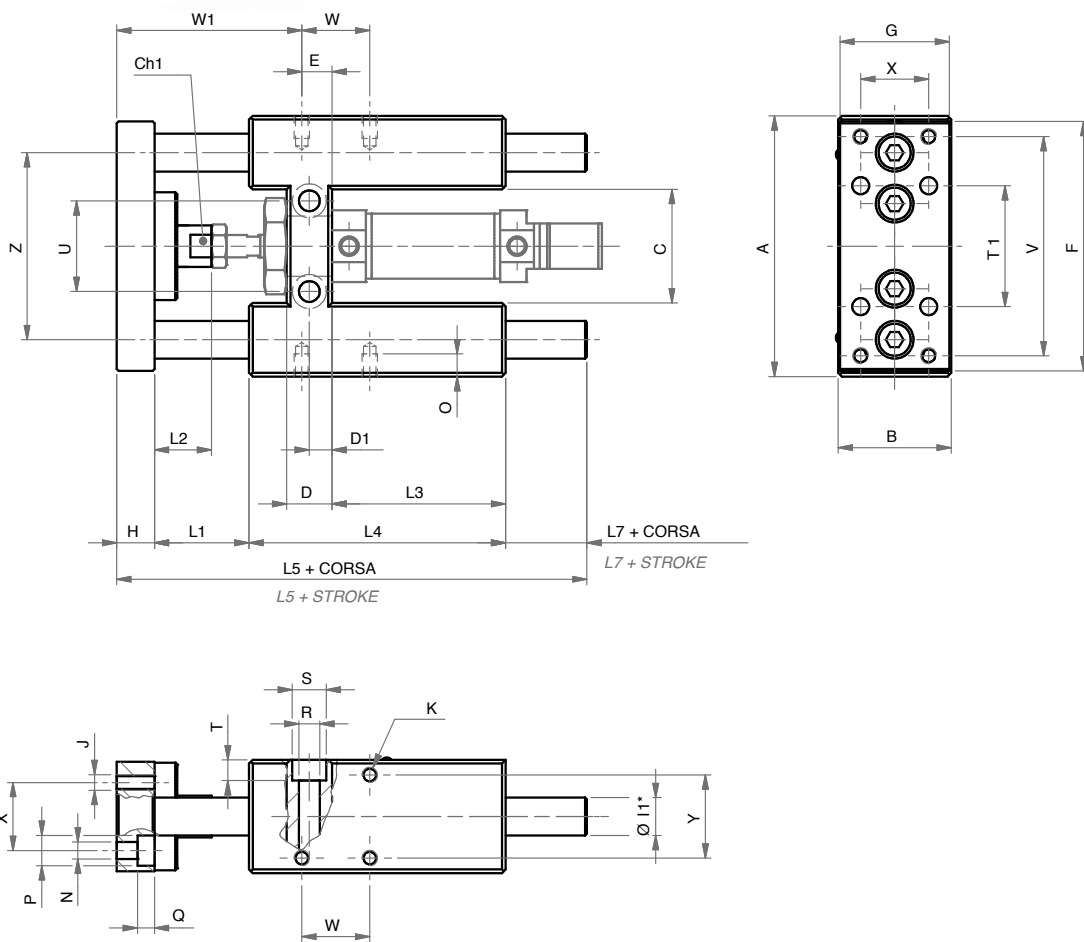

* : Ø11 per unità di guida con boccole in bronzo - for unit guide with bronze bush
 * : Ø12 per unità di guida con cuscinetti a ricircolo di sfere - for unit guide with recirculating ball bearings

GIUNTO LUNGO - LONG COUPLING

Ø	L1	L2	W1
20 - 25	25	40	72

GIUNTO CORTO - SHORT COUPLING

Ø	A	B	C	Ch1	D	D1	E	F	G	H	Ø11	Ø12	J	K	L1	L2	L3	L4
12 - 16	69	30	30	8	12	6	8	66	29	10	10	8	M4	M4	22	18	46	68
20 - 25	79	34	37	12	17	8,5	15	78	32	12	12	10	M5	M6	3	18	58	108

Ø	L5	L7	N	O	P	Q	R	S	T	T1	U	V	W	W1	X	Y	Z
12 - 16	121,5	21,5	4,5	6	8	4,5	5,5	9	5,5	32	30	58	18	46	18	22	49,5
20 - 25	144	21	5,5	9	10	7,5	6,5	11	6	38	37	68	32,5	50	20	23	58

BLOCCASTELO

ROD LOCK

CARATTERISTICHE TECNICHE - TECHNICAL CHARACTERISTICS

Pressione di esercizio - Working pressure	3 ÷ 6 bar		
Temperatura di esercizio - Working temperature	-5 ÷ +80°C (con aria secca - with dry air)		
Alesaggi - Bores	ø 020 - 025		
Tipo di bloccaggio - Type of locking	Meccanico bidirezionale - Mechanical bi-directional		
Fluido - Fluid	aria compressa filtrata, non lubrificata - compressed filtered, non lubricated air		
Forza bloccaggio - Locking force	ø	20	25
	[N]	490	490

ATTENZIONE

Il funzionamento del bloccastelo è di tipo statico (stelo cilindro non in movimento). È necessario arrestare lo stelo del cilindro prima di effettuare il bloccaggio. È possibile sbloccare il bloccastelo solo se le forze nel pistone sono equilibrate, altrimenti si possono verificare incidenti a causa del movimento irregolare dello stelo. Se vengono superati i valori di bloccaggio indicati, si possono verificare slittamenti dello stelo. In condizioni di bloccaggio e con carichi variabili sullo stelo, lo stelo può avere un leggero gioco assiale.

Non togliere l'alimentazione dell'aria in assenza del falso stelo o dello stelo del cilindro

ATTENTION

Rod lock's functioning is of static type (cylinder rod must be stopped). It is necessary to stop the cylinder rod before locking it. It is possible to unblock the rod lock only if the forces in the piston are balanced, otherwise there can be accidents due to the irregular movement of the rod. If the given blocking values are exceeded there can be a sliding on the rod. When it is blocked and the loads are variable on the rod, the rod can have a slight axial play.

Don't remove air feeding when "false" rod or cylinder rod is missing.

CARATTERISTICHE COSTRUTTIVE - CONSTRUCTIVE CHARACTERISTICS

①	Boccola - Bush	delrin
②	Dado - Nut	acciaio zincato - zinc coated steel
③ ④	Molla - Spring	acciaio - steel
⑤ ⑦	Coperchio - Cover	alluminio - aluminium
⑥	Guarnizioni - Seals	poliuretano - polyurethane
⑧ ⑬	Guarnizioni - Seals	NBR
⑨	Pistone - Piston	delrin
⑩	Disco molla - Spring cover	delrin
⑪	Corpo - Body	alluminio anodizzato - anodized aluminium
⑫	Palette - Jaws	bronzo - bronze
	Viti - Screws	acciaio zincato - zinc coated steel

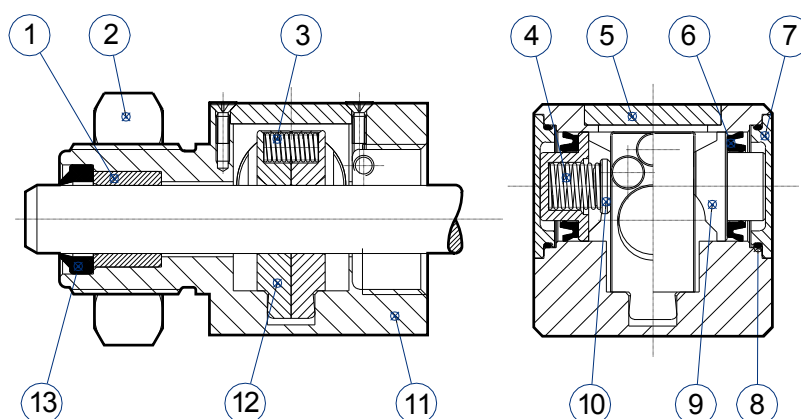

BLOCCASTELO

BH

ROD LOCK

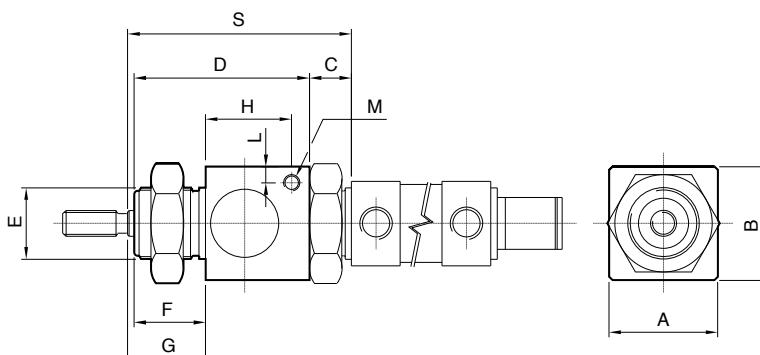

DIMENSIONI - DIMENSION

COD.	A	B	C	D	E	F	G	H	L	M	S
BH020	34	35	13	54	M22x1,5	22	26	27	5	M5	71
BH025	34	35	13	54	M22x1,5	22	28	27	5	M5	73

!!!: Non togliere l'alimentazione dell'aria in assenza dello stelo - Don't stop air in the absence of the rod

Il funzionamento del bloccastelo è di tipo statico (stelo non in movimento). È necessario arrestare lo stelo del cilindro prima di effettuare il bloccaggio.
The rod lock operation is static (rod not moving). The rod must be stopped before locking.

CERNIERA CON PERNO (MP3)

MCFI

FEMALE HINGE WITH PIN (MP3)

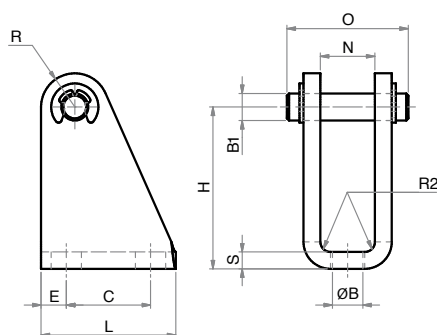

DIMENSIONI - DIMENSIONS

COD.	MCFI008.010	MCFI012.016	MCFI020.025
ø mm	8 - 10	12 - 16	20 - 25
B	4,5	5,5	6,6
B1	4	6	8
C	12,5	15	20
E	3,75	5	6
H	24	27	30
L	20	25	32
N	8,1	12,1	16,1
O	18	24	31
R	5	7	10
R2	1,5	1,5	2
S	2,5	3	4

LA FORNITURA COMPRENDE:

n° 1 CERNIERA FEMMINA

n° 1 PERNO

n° 2 SEEGER

THE SUPPLY INCLUDES:

n° 1 FEMALE HINGE

n° 1 PIN

n° 2 RETAINING RING

MATERIALE: ACCIAIO ZINCATO

MATERIAL: ZINC COATED STEEL

PIEDINO (MS3)

MPBI

FOOT MOUNTING (MS3)



MATERIALE: ACCIAIO ZINCATO
MATERIAL: ZINC COATED STEEL

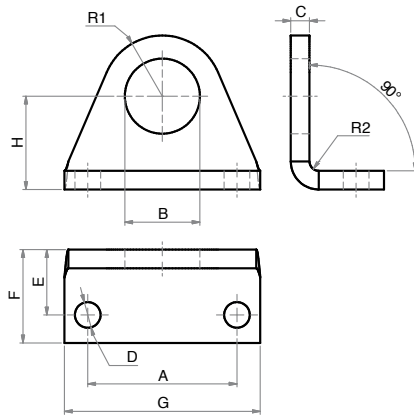

DIMENSIONI - DIMENSIONS

COD.	MPBI008.010	MPBI012.016	MPBI020.025
ø mm	8 - 10	12 - 16	20 - 25
A	25	32	40
B	12	16,1	22,1
C	3	4	5
D	4,5	5,5	6,6
E	11	14	17
F	16	20	25
G	35	42	54
H	16	20	25
R1	10	13	20
R2	1,5	2	2,5

FLANGIA (MF8)

MFI

FLANGE (MF8)



MATERIALE: ACCIAIO ZINCATO
MATERIAL: ZINC COATED STEEL

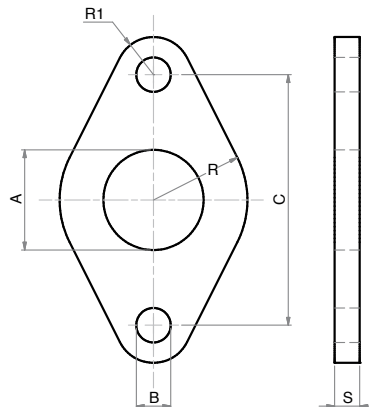

DIMENSIONI - DIMENSIONS

COD.	MFI008.010	MFI012.016	MFI020.025
ø mm	8 - 10	12 - 16	20 - 25
A	12	16	22
B	4,5	5,5	6,5
C	30	40	50
R	11	15	20
R1	5	6	8
S	3	4	5

DADO TESTATA (MR3)

DAT

NOSE NUT (MR3)



MATERIALE: ACCIAIO ZINCATO
MATERIAL: ZINC COATED STEEL

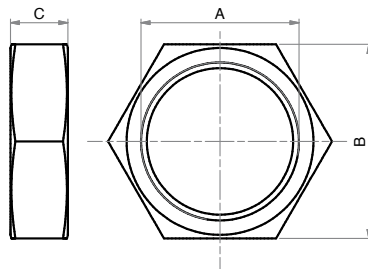

DIMENSIONI - DIMENSIONS

COD.	DAT008.010	DAT012.016	DAT020.025
A	M12x1,25	M16x1,5	M22x1,5
B	19	22	27
C	7	6	8



DADO STELO

DA

PISTON ROD NUT

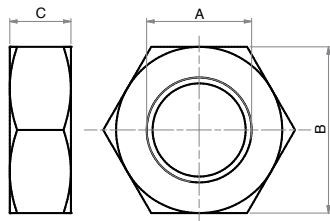

DIMENSIONI - DIMENSIONS

COD.	DA04x0,7	DA06x1	DA08x1,25	DA10x1,25
A	M4x0,7	M6	M8	M10x1,25
B	7	10	13	17
C	4	4	5	6

MATERIALE: ACCIAIO ZINCATO
 MATERIAL: ZINC COATED STEEL

FORCELLA CON CLIPS

FC

CLEVIS WITH LOCKABLE PIN

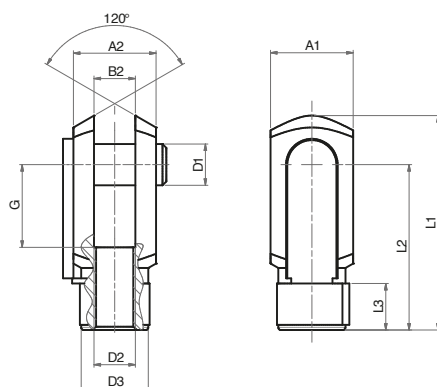

DIMENSIONI - DIMENSIONS

COD.	FC04x0,7	FC06x1	FC08x1,25	FC10x1,25
A1	8	12	16	20
A2	8	12	16	20
B2	4	6	8	10
G	8	12	16	20
L1	21	31	42	52
L2	16	24	32	40
L3	6	9	12	15
ø D1	4	6	8	10
ø D2	M4x0,7	M6x1	M8x1,25	M10x1,25
ø D3	8	10	14	18

LA FORNITURA COMPRENDE:
 n° 1 FORCELLA
 n° 1 CLIPS
 THE SUPPLY INCLUDES:
 n° 1 FORK
 n° 1 LOCKABLE PIN

MATERIALE: ACCIAIO ZINCATO
 MATERIAL: ZINC COATED STEEL

SNODO SFERICO FILETTO INTERNO

SSFI

ROD EYE (INTERNAL THREAD)

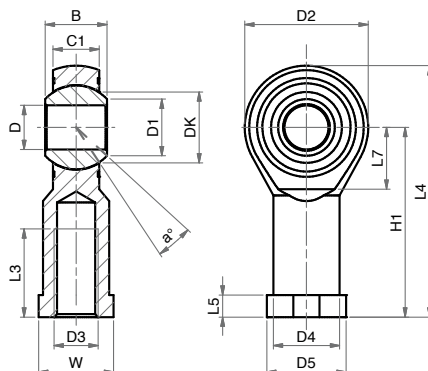

DIMENSIONI - DIMENSIONS

COD.	SSFI04x0,7	SSFI06x1	SSFI08x1,25	SSFI10x1,25
α°	13	13	14	13
B	8	9	12	14
C1	6	6,75	9	10,5
D1	7,7	8,9	10,4	12,9
D2	18	20	24	28
D3	M4	M6	M8	M10x1,25
D4	9	10	12,5	15
D5	11	13	16	19
DK	11,11	12,7	15,87	19,05
D	5	6	8	10
H1	27	30	36	43
L3	10	12	16	20
L4	36	40	48	57
L5	4	5	5	6,5
L7	10	11	13	15
W	9	11	14	17

MATERIALE:
 CORPO IN ACCIAIO ZINCATO
 SNODO IN ACCIAIO,
 BRONZO E PTFE
 MATERIAL:
 BODY IN ZINC COATED STEEL
 EYE IN STEEL, BRONZE
 AND PTFE

SENSORI MAGNETICI

MAGNETIC SENSORS

CARATTERISTICHE - CHARACTERISTICS					
CODICE - CODE		36.SEN06 36.SEN06.L6	36.SEN07	36.SEN08	36.SEN09 36.SEN09.L6 36.SEN09.L10
TIPO - TYPE		REED	REED	ELETTRONICO ELECTRONIC	ELETTRONICO ELECTRONIC
Modello elettrico - Electrical design		AC/DC PNP/NPN	AC/DC PNP/NPN	DC PNP	DC PNP
Funzione dell'uscita - Output		NO	NO	NO	NO
Tensione di esercizio - Operating voltage	[V]	5...120 AC/DC	5...60 DC / 5...50 AC	10...30 DC	10...30 DC
Capacità di corrente - Current rating	[mA]	100*	100*	100	100
Sensibilità di reazione - Magnetic sensitivity	[mT]	2,1	2,1	2,8	2,8
Velocità di passaggio - Travel speed	[m/s]	> 10	> 10	> 10	> 10
Protezione da cortocircuito - Short-circuit proof		no	no	si - yes	si - yes
Protetto da inversione di polarità Reverse polarity protection		si - yes	si - yes	si - yes	si - yes
Resistente a sovraccarico - Overload protection		no	no	si - yes	si - yes
Caduta di tensione - Voltage drop	[V]	< 5	< 5	< 2,5	< 2,5
Isteresi - Hysteresis		1	1	< 1,5	< 1,5
Riproducibilità - Repeatability	[mm]	± 0,2	± 0,2	< 0,2	< 0,2
Corrente assorbita - Current consumption	[mA]	-	-	< 10	< 10
Tempo di commutazione - Make time	[ms]	≤ 0,6	≤ 0,6	-	-
Tempo di riapertura - Fall time	[ms]	≤ 0,1	≤ 0,1	-	-
Potenza max - Switching power max	[W]	10	10	-	-
Cicli di commutazione con connessione a PLC Switching cycles when connected to PLC	[mln]	≤ 40	≤ 40	-	-
Frequenza di commutazione - Switching frequency	[Hz]	1.000	1.000	> 10.000	> 10.000
Temperatura ambiente - Ambient temperature	[°C]	-25...70	-25...70	-25...80	-25...80
Grado/Classe di protezione - Protection		IP67, II	IP67, II	IP67, III	IP67, III
Materiale involucro - Housing material		PA (poliammide - polyamide)			
Materiale eccentrico di fissaggio - Fastening clamp		inox - stainless steel			
Indicazione della funzione Stato di commutazione Function display Switching status	LED	giallo - yellow			
Collegamento - Connection		cavo PUR - PUR cable 2x0,14 mm ² 2 m (.L6 = 6 m)	cavo PUR - PUR cable connettore M8- M8 connector 0,3 m	cavo PUR - PUR cable connettore M8- M8 connector 0,3 m	cavo PUR - PUR cable 3x0,14 mm ² 2 m (.L6 = 6 m .L10 = 10 m)
Peso - Weight	[g]	31,3 69	12	12,1	27,4 73,5 122,4

Accessori inclusi: Segnaposto in gomma, fascetta fermacavo - Accessories included: Rubber placeholder, cable clip

* necessario circuito di protezione esterno per carico induttivo (valvola, relè, ecc...). - External protective circuit for inductive load (valve, contactor, etc...) necessary.

REED: nessuna funzione LED in caso di inversione di polarità nel funzionamento DC. - No LED function in case of polarity reversal in DC operation.



CONTATTO REED (2 FILI)

36.SEN06

36.SEN06.L6

REED CONTACT (2 WIRES)

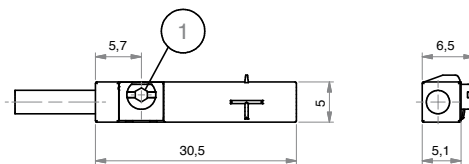

1= ECCENTRICO DI FISSAGGIO - FASTENING CLAMP

CABLAGGIO - WIRING

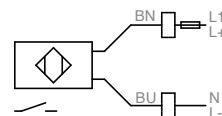

BN= MARRONE - BROWN
BU= BLU - BLUE

CONTATTO REED (CONNETTORE M8)

36.SEN08

36.SEN07

REED CONTACT (M8 CONNECTOR)

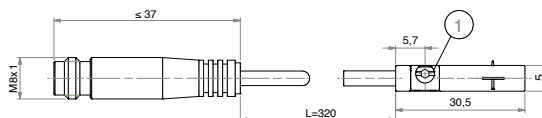

1= ECCENTRICO DI FISSAGGIO - FASTENING CLAMP

CABLAGGIO - WIRING

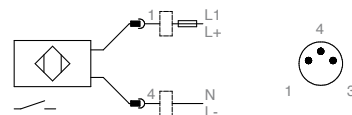

BN= MARRONE - BROWN
BU= BLU - BLUE

CONTATTO PNP (CONNETTORE M8)

36.SEN08

PNP CONTACT (M8 CONNECTOR)

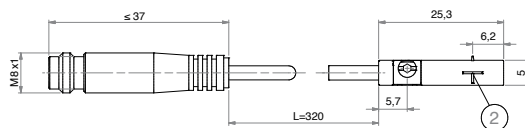

1= ECCENTRICO DI FISSAGGIO FASTENING CLAMP
2= SUPERFICIE ATTIVA SENSING FACE

CABLAGGIO - WIRING

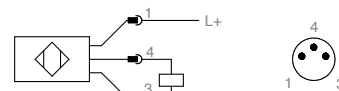

BN= MARRONE - BROWN
BU= BLU - BLUE

CONTATTO PNP (3 FILI)

36.SEN09

36.SEN09.L6

36.SEN09.L10

PNP CONTACT (3 WIRES)

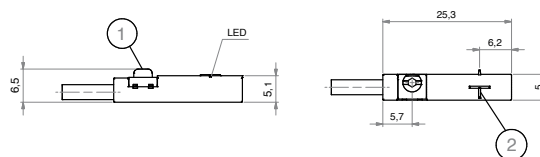

1= ECCENTRICO DI FISSAGGIO - FASTENING CLAMP
2= SUPERFICIE ATTIVA - SENSING FACE

CABLAGGIO - WIRING

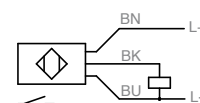

BK= NERO - BLACK
BN= MARRONE - BROWN
BU= BLU - BLUE

CAVO PROLUNGA (CONNETTORE M8)

36.CAV

EXTENSION CABLE (M8 CONNECTOR)

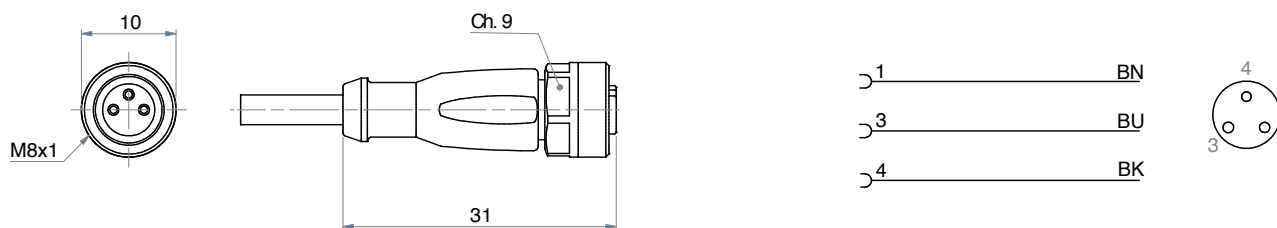

ADATTATORE PER TUBO TONDO

36.TIRM

SENSOR MOUNTING FOR ROUND TUBE

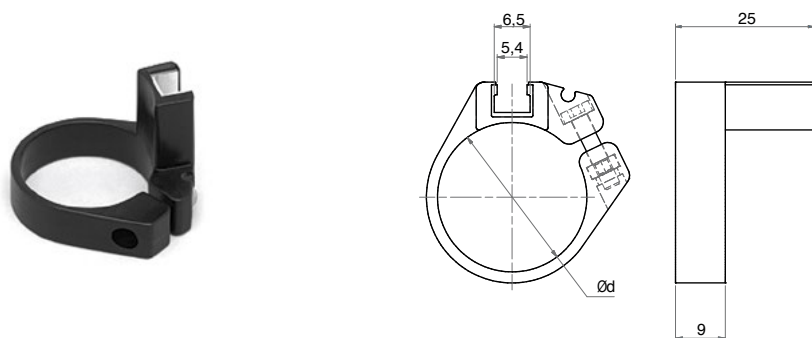

DIMENSIONI - DIMENSION		36.TIRM12	36.TIRM16	36.TIRM20	36.TIRM25
Alesaggio - Bore	[mm]	012	016	020	025
d	[mm]	12	16	20	25
Temperatura - Temperature	[°C]	0÷50			
Materiali - Materials		involucro - housing: POM ; supporto - fixture: alluminio - aluminium; vite-screw: inox - stainless steel			

FASCETTA DI FISSAGGIO

36.TIRX

FIXING CLAMP

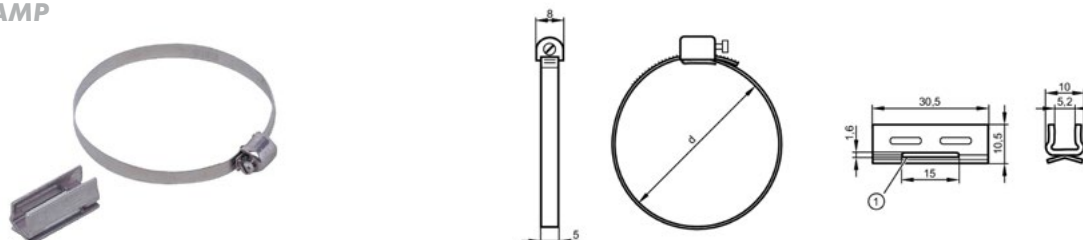

DIMENSIONI DIMENSIONS	36.TIRX08.12	36.TIRX16.20	36.TIRX25.32
Ø	008-012	016-020	025-032
d [mm]	11÷19	18÷29	28÷39
Materiale fascetta Fixing clamp material	acciaio inox AISI 303 - AISI 303 stainless steel		
Materiale adattatore Adapter material	acciaio inox AISI 304 - AISI 304 stainless steel		

SENSORI MAGNETICI ATEX
ATEX MAGNETIC SENSORS

CARATTERISTICHE - CHARACTERISTICS		36.SEN32A.L6	36.SEN33A
TIPO - TYPE		ELETTRONICO - ELECTRONIC	ELETTRONICO - ELECTRONIC
Modello elettrico - Electrical design		DC PNP	DC PNP
Funzione dell'uscita - Output		NO	NO
Tensione di esercizio - Operating voltage	[V]	10...30 DC	10...30 DC
Capacità di corrente - Current rating	[mA]	100	100
Sensibilità di reazione - Magnetic sensitivity	[mT]	2	2,8
Velocità di passaggio - Travel speed	[m/s]	> 10	> 10
Protezione da cortocircuito - Short-circuit proof		si - yes	si - yes
Protetto da inversione di polarità - Reverse polarity protection		si - yes	si - yes
Resistente a sovraccarico - Overload protection		si - yes	si - yes
Caduta di tensione - Voltage drop	[V]	< 2,5	< 2,5
Isteresi - Hysteresis		1	< 1,5
Riproducibilità - Repeatability	[mm]	< 0,2	< 0,2
Corrente assorbita - Current consumption	[mA]	< 10	< 10
Ritardo alla disponibilità - Power-on delay time	[ms]	< 30	< 30
Frequenza di commutazione - Switching frequency	[Hz]	6.000	10.000
Temperatura ambiente - Ambient temperature	[°C]	-20...60	-25...60
Grado/Classe di protezione - Protection		IP 65/IP 67	IP 65/IP 67
Contrassegno - Marking of the unit		II 3D Ex tc IIIC T125°C Dc X II 3G Ex nA IIC T4 Gc X	II 3D Ex tc IIIC T125°C Dc X
Materiale involucro - Housing material		PA (poliammide-polyamide)	PA (poliammide-polyamide)
Materiale eccentrico di fissaggio - Fastening clamp		inox - stainless steel	inox - stainless steel
Indicazione della funzione Stato di commutazione Function display Switching status	LED	giallo - yellow	giallo - yellow
Collegamento - Connection		cavo PVC - PVC cable 3x0,14 mm ²	cavo PVC - PVC cable connettore M12 - M12 connector
Lunghezza cavo - Cable length		6 m	0,3 m
Peso - Weight	[g]	103,3	52,4

Accessori inclusi - Accessories included: Segnaposto in gomma, fascetta fermacavo - Rubber placeholder, cable clip



36.SEN32A.L6

CONTATTO PNP (3 FILI)

PNP CONTACT (3 WIRES)



- 1= ECCENTRICO DI FISSAGGIO - FASTENING CLAMP
- 2= SUPERFICIE ATTIVA - SENSING FACE

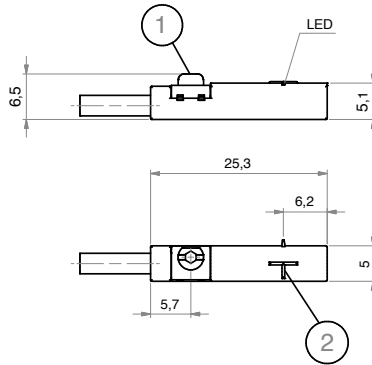

CABLAGGIO - WIRING

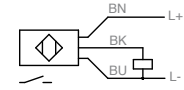

- BK= NERO - BLACK
- BN= MARRONE - BROWN
- BU= BLU - BLUE



36.SEN33A

CONTATTO PNP (CONNETTORE M12)

PNP CONTACT (M12 CONNECTOR)



- 1= ECCENTRICO DI FISSAGGIO - FASTENING CLAMP
- 2= SUPERFICIE ATTIVA - SENSING FACE

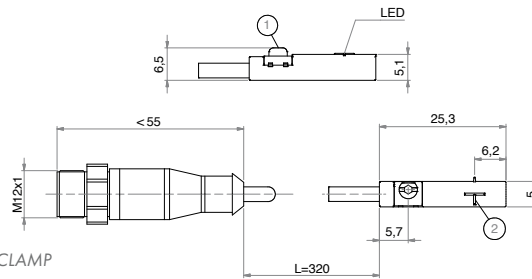

CABLAGGIO - WIRING

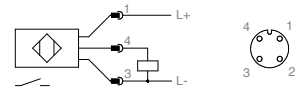

- BK= NERO - BLACK
- BN= MARRONE - BROWN
- BU= BLU - BLUE



36.CAVA

CAVO PROLUNGA (CONNETTORE M12)

EXTENSION CABLE (M12 CONNECTOR)

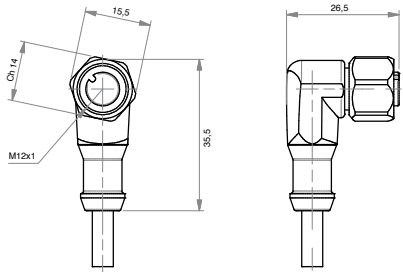

CABLAGGIO - WIRING

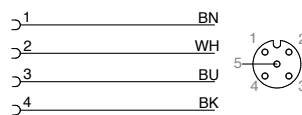

- BK= NERO - BLACK
- BN= MARRONE - BROWN

- BU= BLU - BLUE
- WH= BIANCO - WHITE

DIMENSIONI - DIMENSIONS	36.CAV5A.M12	36.CAV10A.M12
Modello elettrico - Electrical design	AC/DC	AC/DC
Tensione di esercizio - Operating voltage	[V] 60 AC / 60 DC	60 AC / 60 DC
Capacità di corrente - Current rating	[A] 2	2
Modello - Design	ad angolo - angled	ad angolo - angled
Temperatura ambiente - Ambient temperature	[°C] -20...60	-20...60
Grado/Classe di protezione - Protection	IP67/IP68 - IP69K fuori dalla zona esplosiva - outside hazardous areas	
Contrassegno - Marking of the unit	Ex II 3G Ex nA IIC Gc - Ex II 2D Ex tb IIIC Db IP65/IP67	
Materiale corpo - Body material: Involucro - Housing	TPU arancione - orange TPU	TPU arancione - orange TPU
Guarnizione - Sealing	viton	viton
Materiale dado - Nut material	inox - stainless steel (1.4404 / 316L)	inox - stainless steel (1.4404 / 316L)
Coppia di serraggio per nodo nocciolo Tightening torque for knurled nut	[Nm] 0,2...1,5	0,2...1,5
Collegamento - Connection	cavo PUR - PUR cable / 5 m; 4 x 0,34 mm ² (42 x Ø 0,1 mm); Ø 4,9 mm; senza alogeno - alogen free	cavo PUR - PUR cable / 10 m; 4 x 0,34 mm ² (42 x Ø 0,1 mm); Ø 4,9 mm; senza alogeno - alogen free
Colore della guaina - Sheath colour	nero - black	nero - black

AIR

THE BEST WAY TO



ARTEC SRL Via B. Zallone, 24

44042 CENTO (FE) - ITALY

☎ +39 051 683 62 20

☎ +39 051 683 08 82

✉ info@artec-pneumatic.com

🌐 www.artec-pneumatic.com



AZIENDA CON SISTEMA
DI GESTIONE QUALITÀ
CERTIFICATO ISO 9001:2015

PARTNER IN THE U.S.A & CANADA



W.C. Branham, Inc.

398 Troy Street

River Falls, WI 54022

☎ 800-428-1974 (Toll-free US & Canada)

715-426-2000 (Main)

☎ 715-426-1400

✉ AskWCB@wcbranham.com

🌐 www.wcbranham.com