

SERIE

P

CILINDRI COMPATTI ISO 21287
ISO 21287 COMPACT CYLINDERS

ARTEC[®]
PNEUMATIC COMPONENTS



WC BRANHAM[®]
SOLUTIONS IN MOTION

CARATTERISTICHE TECNICHE - TECHNICAL CHARACTERISTICS

Pressione di esercizio <i>Working pressure</i>	1 ÷ 10 bar (doppio effetto - <i>double acting</i>) 2 ÷ 10 bar (semplice effetto - <i>single acting</i>)
Temperatura di esercizio <i>Working temperature</i>	0 ÷ +80 °C (-20 °C con aria secca - <i>with dry air</i>) 0 ÷ +150 °C (con guarnizioni per alte temperature - <i>with high temperature seals</i>)
Versioni - Versions	semplice effetto - doppio effetto - antirrotazione - stelo passante - tandem <i>single acting - double acting - anti-rotary - double rod - tandem</i>
Alesaggi - Bores	∅ 20 - 25 - 32 - 40 - 50 - 63 - 80 - 100 - 125
Corse - Strokes	vedere tabelle corse standard - <i>see standard stroke tables</i>
Fluido - Fluid	aria compressa filtrata, non lubrificata - <i>compressed filtered, non lubricated air</i>

CARATTERISTICHE COSTRUTTIVE - CONSTRUCTIVE CHARACTERISTICS

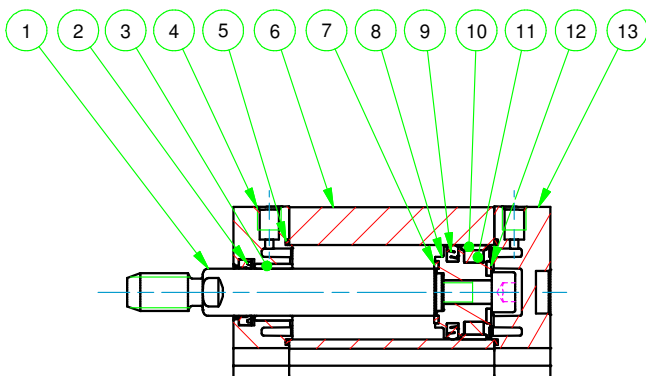
①	Stelo - Rod	acciaio inox AISI 303 - <i>stainless steel AISI 303</i>
②	Guarnizione stelo - Rod seal	poliuretano - <i>polyurethane</i>
③	Boccola - Bush	acciaio+PTFE - <i>steel+PTFE</i>
④ ⑬	Testate - Covers	alluminio pressofuso verniciato - <i>painted die cast aluminium</i>
⑤	O-ring	NBR
⑥	Tubo - Tube	alluminio anodizzato - <i>anodized aluminium</i>
⑦ ⑫	Paracolpo - Bumper	NBR (∅ 20 -25)
⑧	Pistone - Piston	alluminio - <i>aluminium</i>
⑨	Guarnizione pistone - Piston seal	NBR (∅ 20 -25) - PU (∅ 32 ÷ 125)
⑩	Pattino di guida - Guide ring	PBT+PTFE (∅ 20 -25)
⑪	Magnete - Magnet	plastoferrite - <i>rubber magnet</i>
	Viti - Screws	acciaio zincato - <i>zinc coated steel</i>
	Molla - Spring	acciaio - <i>steel</i>
	Dado stelo - Rod nut	acciaio zincato - <i>zinc coated steel</i>



∅20 - ∅25

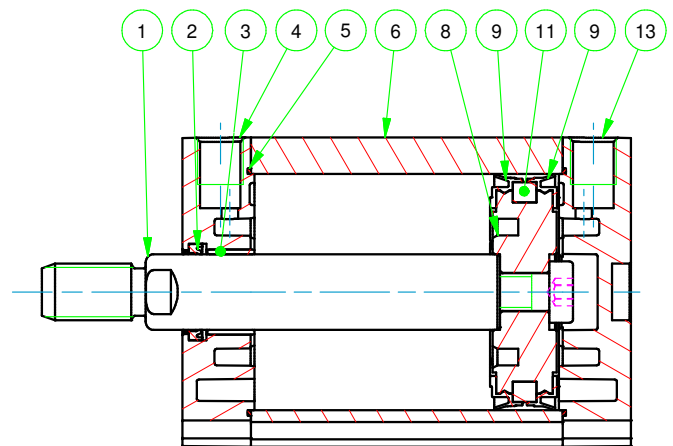

∅32 ÷ ∅125

DIAGRAMMA TEORICO CARICO AMMISSIBILE

PDM

PSM

PSEM

THEORETICAL ALLOWABLE LOAD

SERIE
P



DIAGRAMMA TEORICO CARICO AMMISSIBILE

PDMA

THEORETICAL ALLOWABLE LOAD

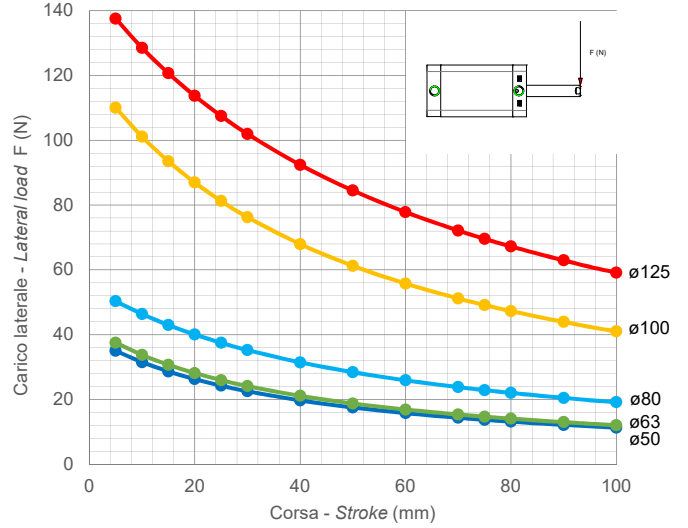
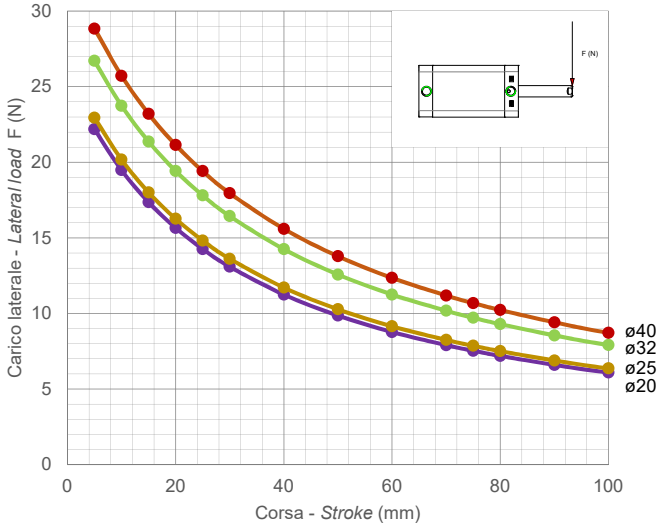

DIAGRAMMA TEORICO CARICO AMMISSIBILE

THEORETICAL ALLOWABLE LOAD

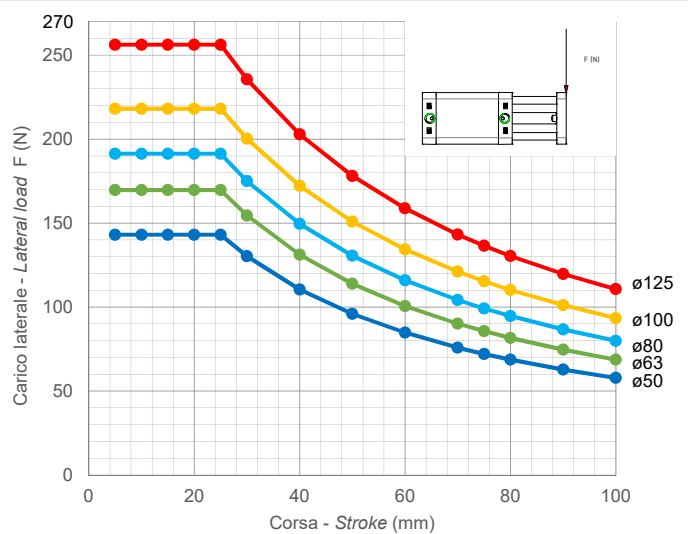
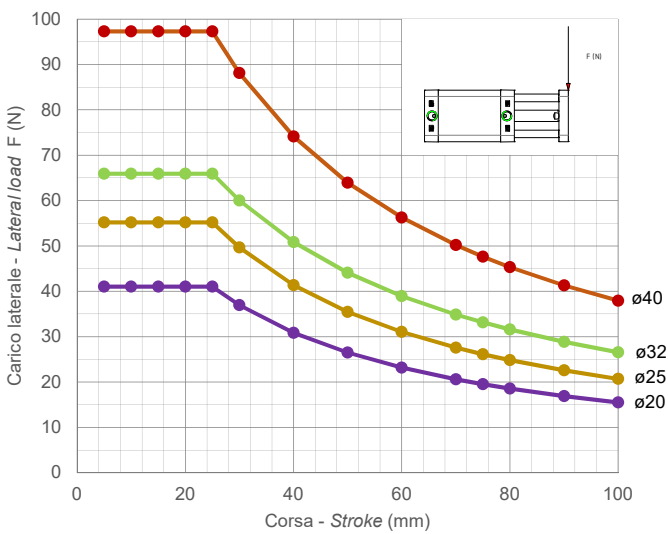
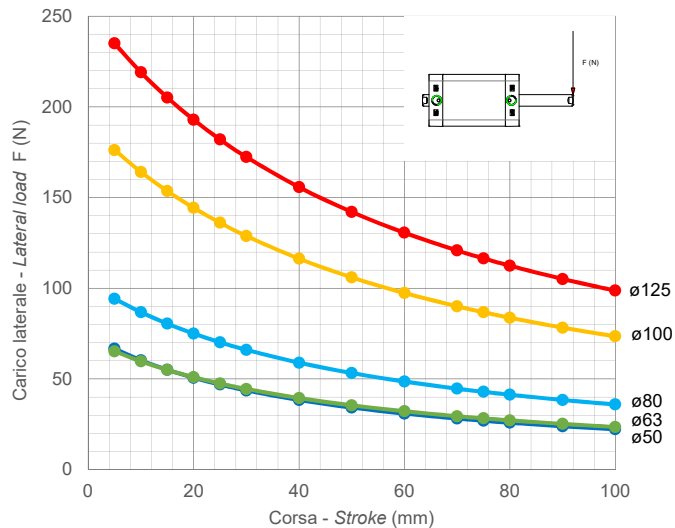
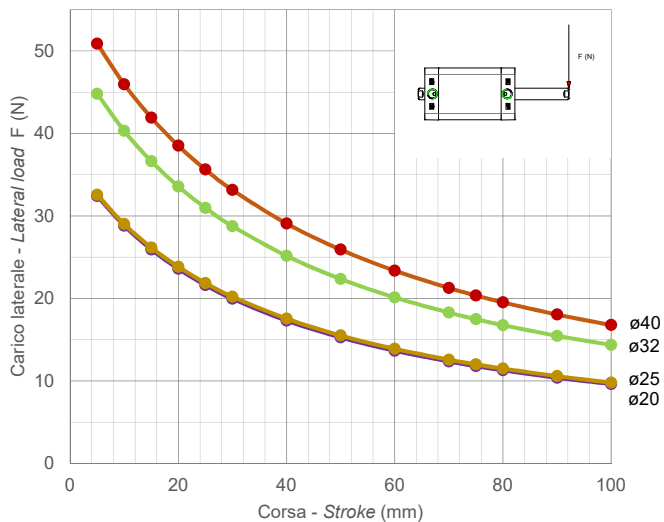

SERIE
P

DIAGRAMMA TEORICO COPPIA AMMISSIBILE

PDMA

PDMPA

THEORETICAL ALLOWABLE TORQUE

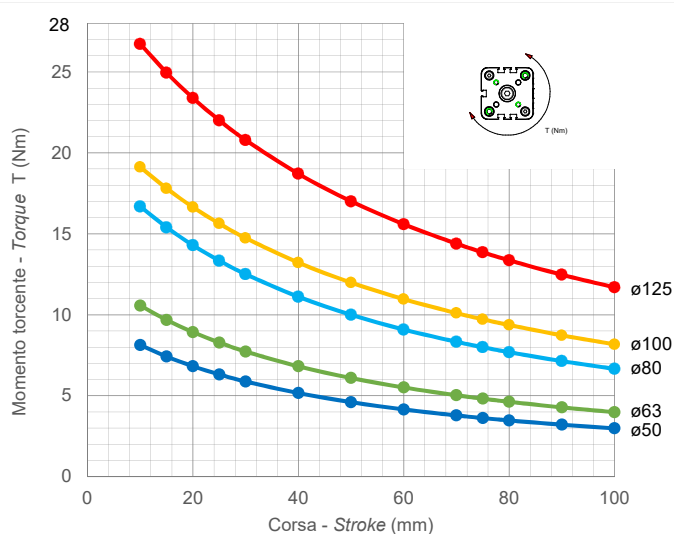
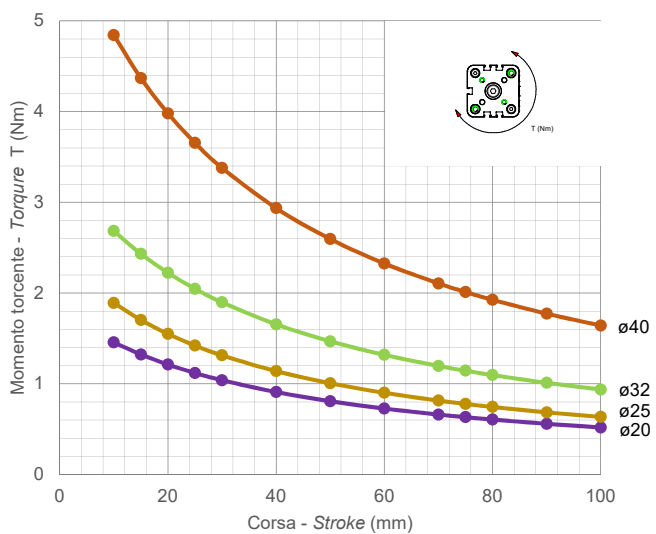

SEMPLICE EFFETTO MAGNETICO - MOLLA ANTERIORE

SINGLE ACTING MAGNETIC - FRONT SPRING

SERIE
P

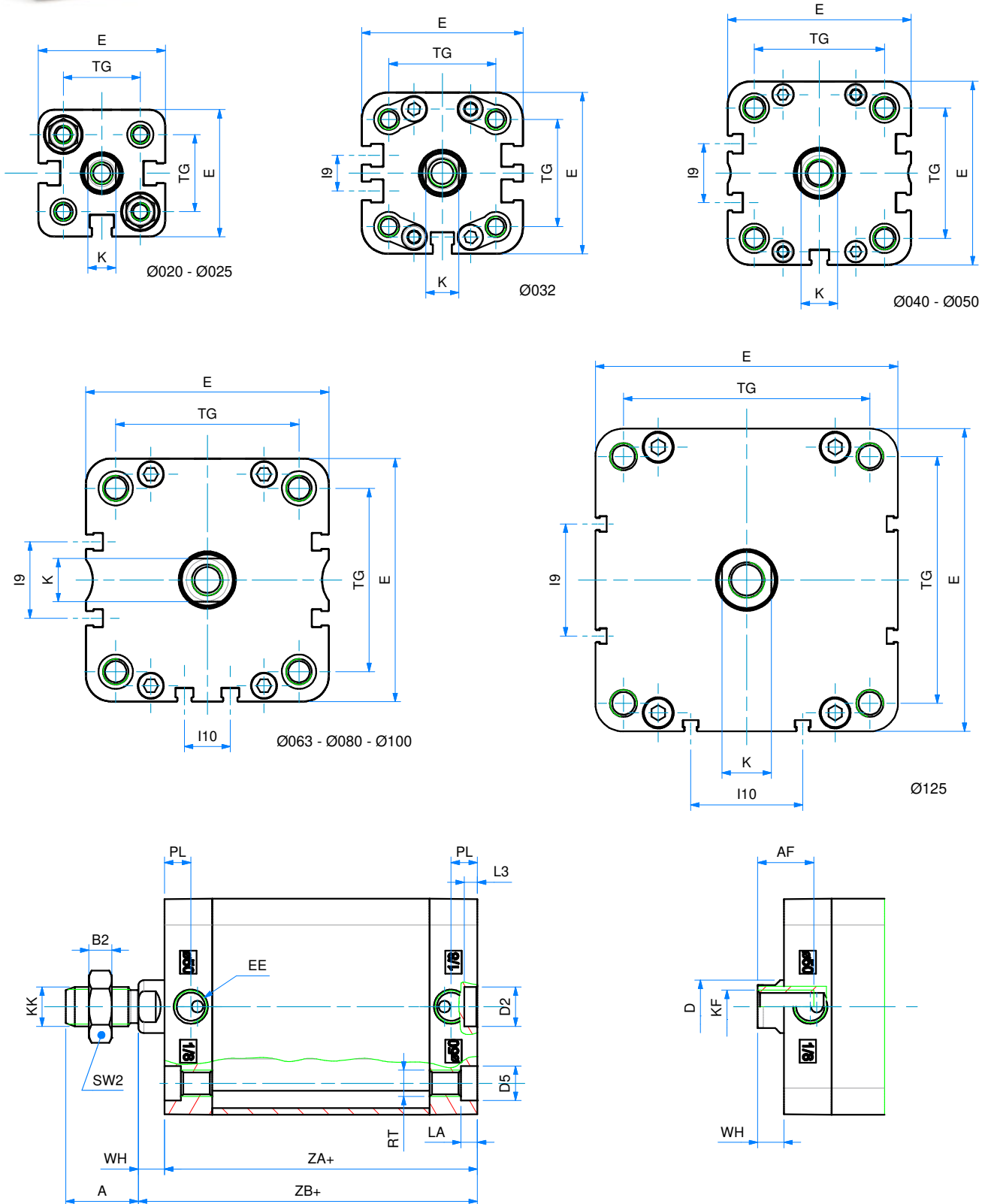
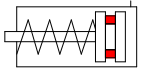

SEMPLICE EFFETTO MAGNETICO - MOLLA ANTERIORE
SINGLE ACTING MAGNETIC - FRONT SPRING

DIMENSIONI - DIMENSIONS									
Ø	020	025	032	040	050	063	080	100	125
A	16	16	19	19	22	22	28	28	40
AF	15	15	15	15	17	17	20	22	25
B2	5	5	6	6	7	7	8	8	9
Ø D	10	10	12	12	16	16	20	25	25
Ø D2	9	9	9	9	12	12	12	12	12
Ø D5	7,5	7,5	9	9	10,5	10,5	13,5	13,5	13,5
E	36	40	49	54,5	65,5	77	95,5	113,5	135
EE	M5	M5	G1/8	G1/8	G1/8	G1/8	G1/8	G1/8	G1/4
I9	-	-	10,8	12,8	21	25,8	30	50	50
I 10	-	-	-	-	-	13	18	35	50
K	8	8	10	10	13	13	17	22	22
KF	M6	M6	M8	M8	M10	M10	M12	M12	M16
KK	M8	M8	M10x1,25	M10x1,25	M12x1,25	M12x1,25	M16x1,5	M16x1,5	M20x1,5
LA	4,5	4,5	5	5	5	5	3	3	-
L3	3	3	3	3	4	4	4	4	4
PL	7,5	7,5	7,5	8	8	7,5	8	10,5	10,5
RT	M5	M5	M6	M6	M8	M8	M10	M10	M12
SW2	13	13	17	17	19	19	24	24	30
TG	22	26	32,5	38	46,5	56,5	72	89	110
WH	6,5	6	6,5	7	8	8	9	10	11
ZA+	37*	39*	44*	45*	45*	49*	54*	67*	81
ZB+	43,5*	45*	50,5*	52*	53*	57*	63*	77*	92

+ = aggiungere lunghezza corsa (mm) - add stroke length (mm)

Note: dado stelo compreso nella fornitura

Note: rod nut included in the supply

* per corse - for strokes 035 - 040 - 050 - 060:

PSM 020 aggiungere - add +10 mm

PSM 025 - 032 - 040 - 050 - 063 aggiungere - add +20 mm

PSM 080 - 100 aggiungere - add +30 mm

Ø	CORSE STANDARD - STANDARD STROKES
020	5 - 10 - 15 - 20 - 25 - 30 - 35 - 40 - 50 - 60
025	5 - 10 - 15 - 20 - 25 - 30 - 35 - 40 - 50 - 60
032	5 - 10 - 15 - 20 - 25 - 30 - 35 - 40 - 50 - 60
040	5 - 10 - 15 - 20 - 25 - 30 - 35 - 40 - 50 - 60
050	5 - 10 - 15 - 20 - 25 - 30 - 35 - 40 - 50 - 60
063	5 - 10 - 15 - 20 - 25 - 30 - 35 - 40 - 50 - 60
080	5 - 10 - 15 - 20 - 25 - 30 - 35 - 40 - 50 - 60
100	5 - 10 - 15 - 20 - 25 - 30 - 35 - 40 - 50 - 60
125	5 - 10 - 15 - 20 - 25 - 30

SEMPLICE EFFETTO MAGNETICO - MOLLA POSTERIORE

SINGLE ACTING MAGNETIC - REAR SPRING

SERIE

P

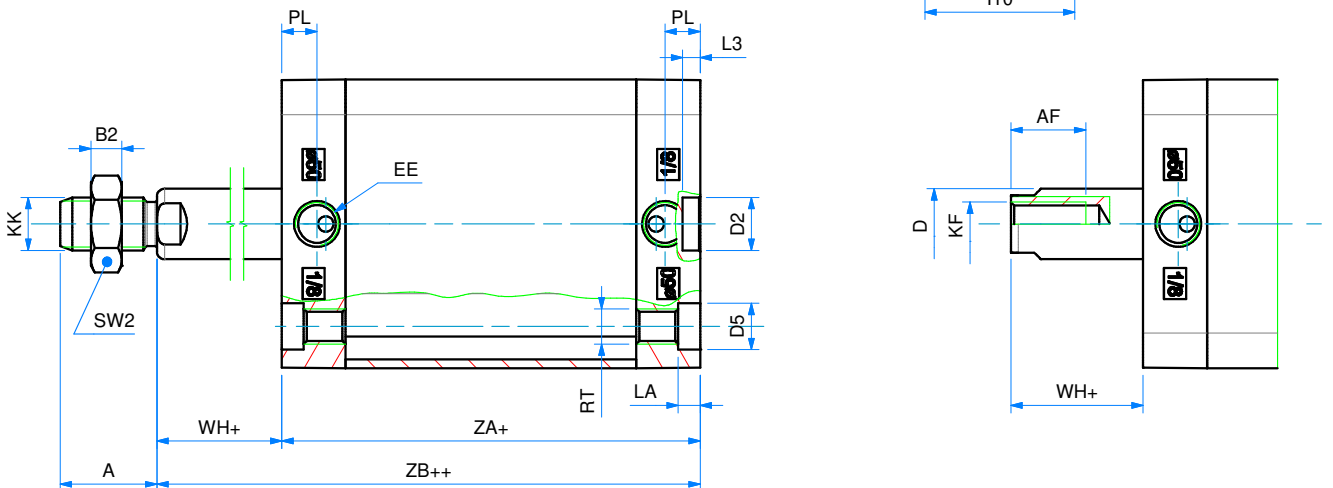
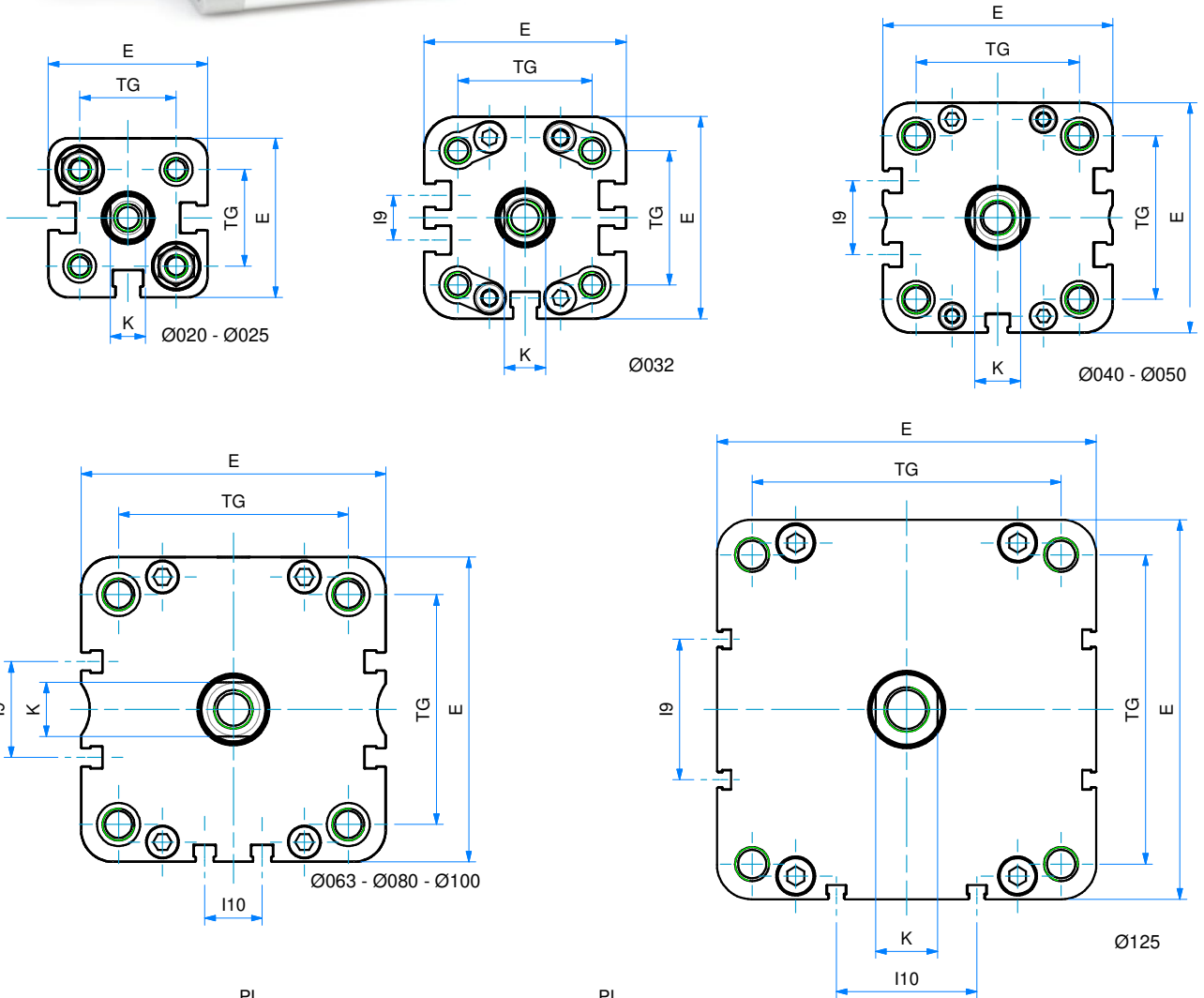
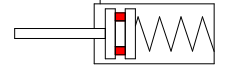
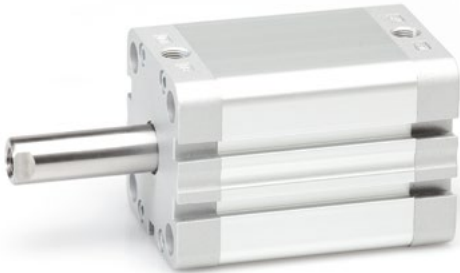

SEMPLICE EFFETTO MAGNETICO - MOLLA POSTERIORE
SINGLE ACTING MAGNETIC - REAR SPRING

DIMENSIONI - DIMENSIONS									
Ø	020	025	032	040	050	063	080	100	125
A	16	16	19	19	22	22	28	28	40
AF	15	15	15	15	17	17	20	22	25
B2	5	5	6	6	7	7	8	8	9
Ø D	10	10	12	12	16	16	20	25	25
Ø D2	9	9	9	9	12	12	12	12	12
Ø D5	7,5	7,5	9	9	10,5	10,5	13,5	13,5	13,5
E	36	40	49	54,5	65,5	77	95,5	113,5	135
EE	M5	M5	G1/8	G1/8	G1/8	G1/8	G1/8	G1/8	G1/4
I9	-	-	10,8	12,8	21	25,8	30	50	50
I10	-	-	-	-	-	13	18	35	50
K	8	8	10	10	13	13	17	22	22
KF	M6	M6	M8	M8	M10	M10	M12	M12	M16
KK	M8	M8	M10x1,25	M10x1,25	M12x1,25	M12x1,25	M16x1,5	M16x1,5	M20x1,5
LA	4,5	4,5	5	5	5	5	3	3	-
L3	3	3	3	3	4	4	4	4	4
PL	7,5	7,5	7,5	8	8	7,5	8	10,5	10,5
RT	M5	M5	M6	M6	M8	M8	M10	M10	M12
SW2	13	13	17	17	19	19	24	24	30
TG	22	26	32,5	38	46,5	56,5	72	89	110
WH+	6,5	6	6,5	7	8	8	9	10	11
ZA+	37*	39*	44*	45*	45*	49*	54*	67*	81
ZB++	43,5*	45*	50,5*	52*	53*	57*	63*	77*	92

+ = aggiungere lunghezza corsa (mm) - add stroke length (mm)

++ = 2 x lunghezza corsa - 2 x stroke length

Note: dado stelo compreso nella fornitura

Note: rod nut included in the supply

* per corse - for strokes 035 - 040 - 050 - 060:

PSEM 020 - 025 - 032 - 040 - 050 - 063 aggiungere - add +10 mm

PSEM 080 - 100 aggiungere - add +20 mm

Ø	CORSE STANDARD - STANDARD STROKES
020	5 - 10 - 15 - 20 - 25 - 30 - 35 - 40 - 50 - 60
025	5 - 10 - 15 - 20 - 25 - 30 - 35 - 40 - 50 - 60
032	5 - 10 - 15 - 20 - 25 - 30 - 35 - 40 - 50 - 60
040	5 - 10 - 15 - 20 - 25 - 30 - 35 - 40 - 50 - 60
050	5 - 10 - 15 - 20 - 25 - 30 - 35 - 40 - 50 - 60
063	5 - 10 - 15 - 20 - 25 - 30 - 35 - 40 - 50 - 60
080	5 - 10 - 15 - 20 - 25 - 30 - 35 - 40 - 50 - 60
100	5 - 10 - 15 - 20 - 25 - 30 - 35 - 40 - 50 - 60
125	5 - 10 - 15 - 20 - 25 - 30

DOPPIO EFFETTO MAGNETICO
DOUBLE ACTING MAGNETIC
DIMENSIONI - DIMENSIONS

Ø	020	025	032	040	050	063	080	100	125
A	16	16	19	19	22	22	28	28	40
AF	15	15	15	15	17	17	20	22	25
B2	5	5	6	6	7	7	8	8	9
Ø D	10	10	12	12	16	16	20	25	25
Ø D2	9	9	9	9	12	12	12	12	12
Ø D5	7,5	7,5	9	9	10,5	10,5	13,5	13,5	-
E	36	40	49	54,5	65,5	77	95,5	113,5	135
EE	M5	M5	G1/8	G1/8	G1/8	G1/8	G1/8	G1/8	G1/4
I9	-	-	10,8	12,8	21	25,8	30	50	50
I10	-	-	-	-	-	13	18	35	50
K	8	8	10	10	13	13	17	22	22
KF	M6	M6	M8	M8	M10	M10	M12	M12	M16
KK	M8	M8	M10x1,25	M10x1,25	M12x1,25	M12x1,25	M16x1,5	M16x1,5	M 20x1,5
LA	4,5	4,5	5	5	5	5	3	3	-
L3	3	3	3	3	4	4	4	4	4
PL	7,5	7,5	7,5	8	8	7,5	8	10,5	10,5
RT	M5	M5	M6	M6	M8	M8	M10	M10	M12
SW2	13	13	17	17	19	19	24	24	30
TG	22	26	32,5	38	46,5	56,5	72	89	110
WH	6,5	6	6,5	7	8	8	9	10	11
ZA+	37	39	44	45	45	49	54	67	81
ZB+	43,5	45	50,5	52	53	57	63	77	92

+ = aggiungere lunghezza corsa (mm) - add stroke length (mm)

 Note: dado stelo compreso nella fornitura
 Note: rod nut included in the supply

OPZIONE V (FEMMINA) - Z (MASCIO) - OPTION V (FEMALE) - Z (MALE)

Ø	020	025	032	040	050	063	080	100
A	16	22	22	24	32	32	40	40
AF	12	12	15	15	20	20	22	22
Ø D	10	10	12	16	20	20	25	25
K	8	8	10	13	17	17	22	22
KF	M5	M6	M6	M6	M8	M8	M10	M12
KK	M8	M10x1,25	M10x1,25	M12x1,25	M16x1,5	M16x1,5	M20x1,5	M20x1,5

Ø CORSE STANDARD - STANDARD STROKES

020	5 - 10 - 15 - 20 - 25 - 30 - 40 - 50 - 60 - 70 - 75 - 80 - 90 - 100 - 125 - 160 - 200 - 250
025	5 - 10 - 15 - 20 - 25 - 30 - 40 - 50 - 60 - 70 - 75 - 80 - 90 - 100 - 125 - 160 - 200 - 250
032	5 - 10 - 15 - 20 - 25 - 30 - 40 - 50 - 60 - 70 - 75 - 80 - 90 - 100 - 125 - 160 - 200 - 250 - 300 - 350 - 400
040	5 - 10 - 15 - 20 - 25 - 30 - 40 - 50 - 60 - 70 - 75 - 80 - 90 - 100 - 125 - 160 - 200 - 250 - 300 - 350 - 400
050	5 - 10 - 15 - 20 - 25 - 30 - 40 - 50 - 60 - 70 - 75 - 80 - 90 - 100 - 125 - 160 - 200 - 250 - 300 - 350 - 400
063	5 - 10 - 15 - 20 - 25 - 30 - 40 - 50 - 60 - 70 - 75 - 80 - 90 - 100 - 125 - 160 - 200 - 250 - 300 - 350 - 400
080	5 - 10 - 15 - 20 - 25 - 30 - 40 - 50 - 60 - 70 - 75 - 80 - 90 - 100 - 125 - 160 - 200 - 250 - 300 - 350 - 400
100	5 - 10 - 15 - 20 - 25 - 30 - 40 - 50 - 60 - 70 - 75 - 80 - 90 - 100 - 125 - 160 - 200 - 250 - 300 - 350 - 400
125	5 - 10 - 15 - 20 - 25 - 30 - 40 - 50 - 60 - 70 - 75 - 80 - 90 - 100 - 125 - 160 - 200 - 250 - 300 - 350 - 400

DOBPIO EFFETTO MAGNETICO ANTIROTAZIONE

DOUBLE ACTING MAGNETIC ANTI-ROTATION

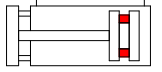

SERIE
P

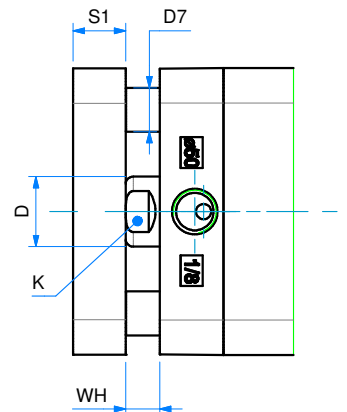
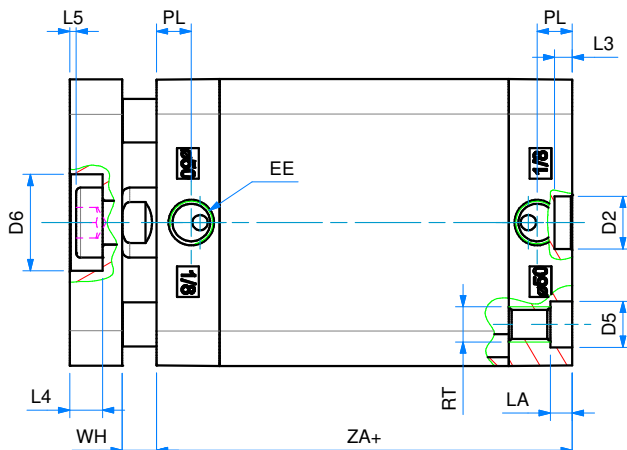
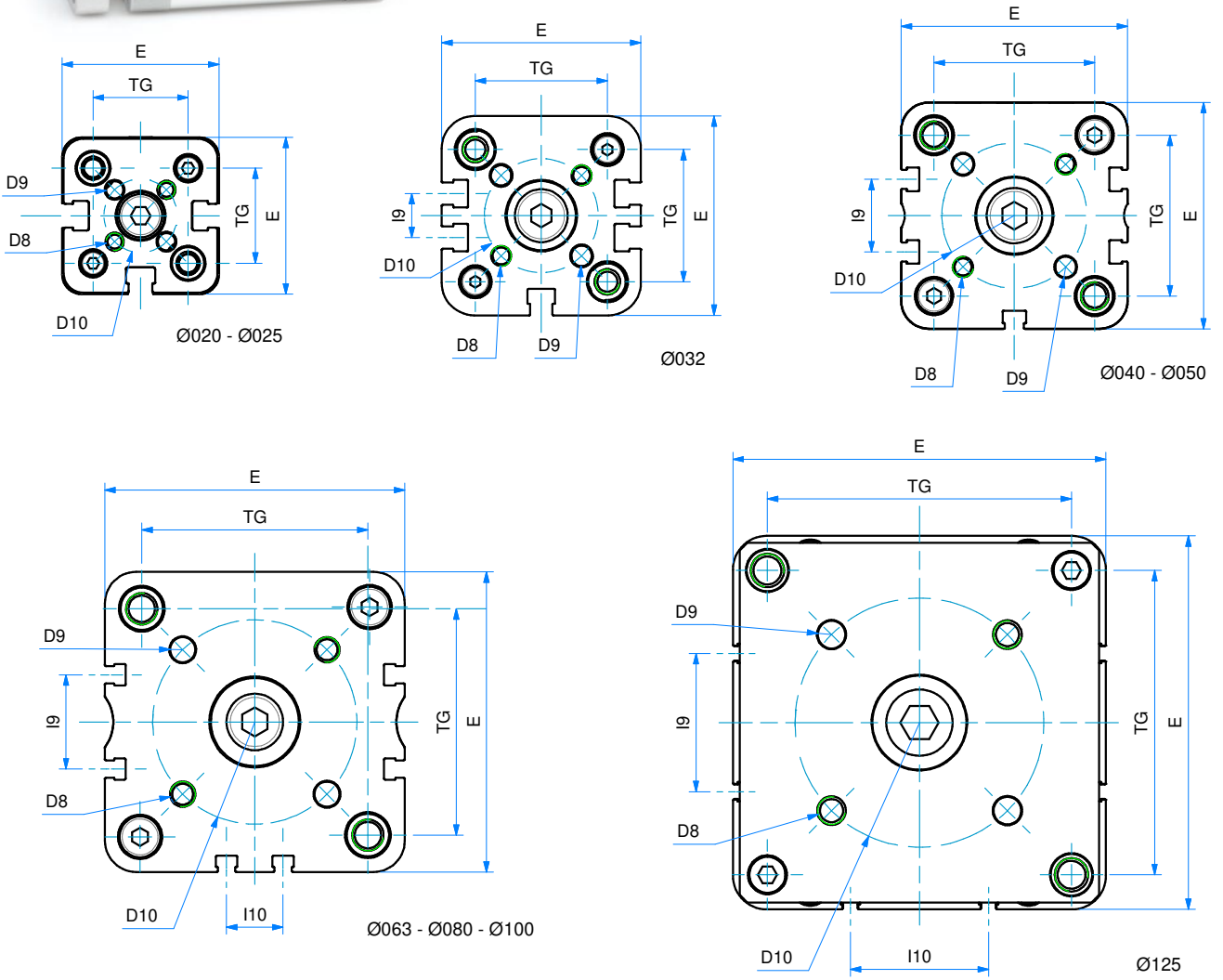

DOPPIO EFFETTO MAGNETICO ANTIROTAZIONE
DOUBLE ACTING MAGNETIC ANTI-ROTATION

DIMENSIONI - DIMENSIONS									
Ø	020	025	032	040	050	063	080	100	125
Ø D	10	10	12	12	16	16	20	25	25
Ø D2	9	9	9	9	12	12	12	12	12
Ø D5	7,5	7,5	9	9	10,5	10,5	13,5	13,5	13,5
Ø D6	11	14	17	17	22	22	28	30	34
Ø D7	5	6	6	8	10	10	14	14	14
D8	M4	M5	M5	M5	M6	M6	M8	M10	M10
Ø D9	4	5	5	5	6	6	8	10	10
Ø D10	17	22	28	33	42	50	65	80	90
E	36	40	49	54,5	65,5	77	95,5	113,5	135
EE	M5	M5	G1/8	G1/8	G1/8	G1/8	G1/8	G1/8	G1/4
I9	-	-	10,8	12,8	21	25,8	30	50	50
I10	-	-	-	-	-	13	18	35	50
K	8	8	10	10	13	13	17	22	22
LA	4,5	4,5	5	5	5	5	3	3	-
L3	3	3	3	3	4	4	4	4	4
L4	5	5	6,5	6,5	7,5	7,5	9	10	11,2
L5	1	1	1,5	1,5	1,5	1,5	2	3	2,2
PL	7,5	7,5	7,5	8	8	7,5	8	10,5	10,5
RT	M5	M5	M6	M6	M8	M8	M10	M10	M12
S1	8	8	10	10	12	12	14	14	18
TG	22	26	32,5	38	46,5	56,5	72	89	110
WH	6,5	6	6,5	7	8	8	9	10	11
ZA+	37	39	44	45	45	49	54	67	81
ZB+	43,5	45	50,5	52	53	57	63	77	92

+ = aggiungere lunghezza corsa (mm) - add stroke length (mm)

 Note: dado stelo compreso nella fornitura
 Note: rod nut included in the supply

Ø	CORSE STANDARD - STANDARD STROKES
020	5 - 10 - 15 - 20 - 25 - 30 - 40 - 50 - 60 - 70 - 75 - 80 - 90 - 100 - 125 - 160 - 200
025	5 - 10 - 15 - 20 - 25 - 30 - 40 - 50 - 60 - 70 - 75 - 80 - 90 - 100 - 125 - 160 - 200
032	5 - 10 - 15 - 20 - 25 - 30 - 40 - 50 - 60 - 70 - 75 - 80 - 90 - 100 - 125 - 160 - 200 - 250 - 300 - 350 - 400
040	5 - 10 - 15 - 20 - 25 - 30 - 40 - 50 - 60 - 70 - 75 - 80 - 90 - 100 - 125 - 160 - 200 - 250 - 300 - 350 - 400
050	5 - 10 - 15 - 20 - 25 - 30 - 40 - 50 - 60 - 70 - 75 - 80 - 90 - 100 - 125 - 160 - 200 - 250 - 300 - 350 - 400
063	5 - 10 - 15 - 20 - 25 - 30 - 40 - 50 - 60 - 70 - 75 - 80 - 90 - 100 - 125 - 160 - 200 - 250 - 300 - 350 - 400
080	5 - 10 - 15 - 20 - 25 - 30 - 40 - 50 - 60 - 70 - 75 - 80 - 90 - 100 - 125 - 160 - 200 - 250 - 300 - 350 - 400
100	5 - 10 - 15 - 20 - 25 - 30 - 40 - 50 - 60 - 70 - 75 - 80 - 90 - 100 - 125 - 160 - 200 - 250 - 300 - 350 - 400
125	5 - 10 - 15 - 20 - 25 - 30 - 40 - 50 - 60 - 70 - 75 - 80 - 90 - 100 - 125 - 160 - 200 - 250 - 300 - 350 - 400

DOPPIO EFFETTO MAGNETICO STELO PASSANTE

DOUBLE ACTING MAGNETIC WITH DOUBLE ROD

SERIE

P

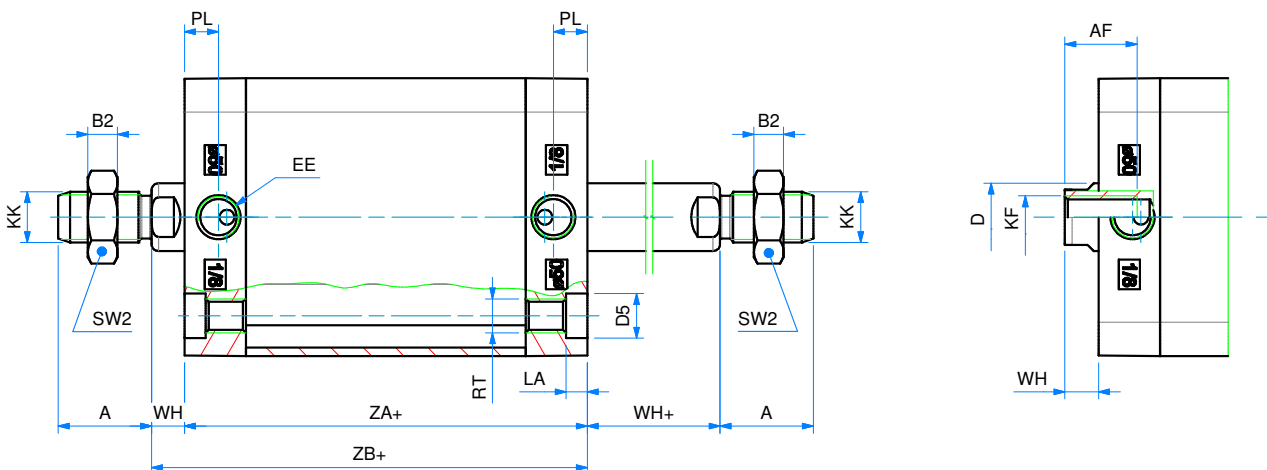
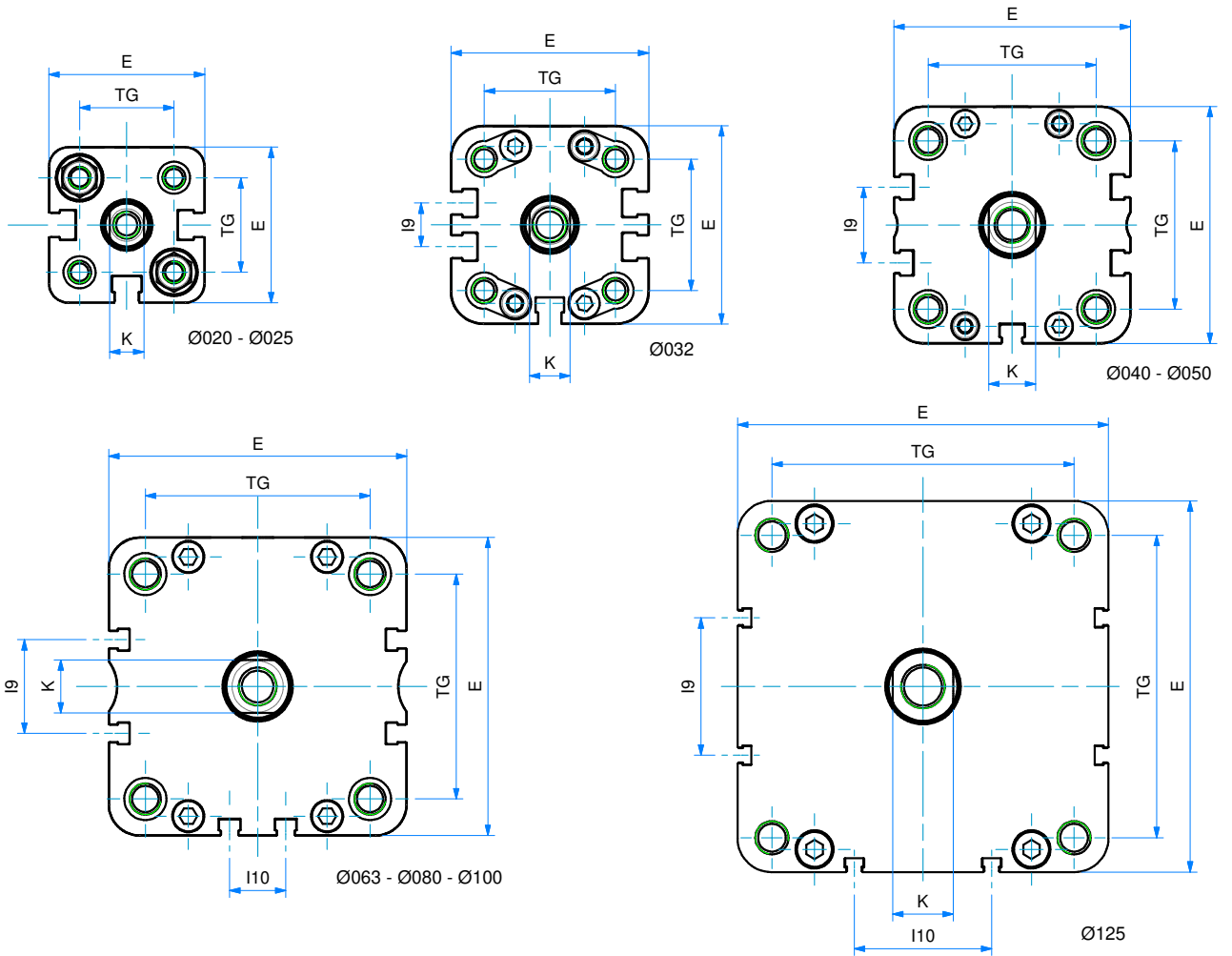
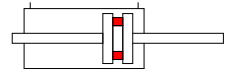
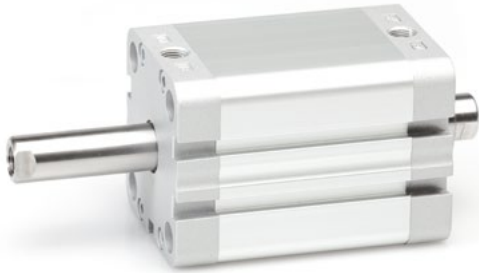

DOPPIO EFFETTO MAGNETICO STELO PASSANTE
DOUBLE ACTING MAGNETIC WITH DOUBLE ROD

DIMENSIONI - DIMENSIONS									
Ø	020	025	032	040	050	063	080	100	125
A	16	16	19	19	22	22	28	28	40
AF	15	15	15	15	17	17	20	22	25
B2	5	5	6	6	7	7	8	8	9
Ø D	10	10	12	12	16	16	20	25	25
Ø D5	7,5	7,5	9	9	10,5	10,5	13,5	13,5	-
E	36	40	49	54,5	65,5	77	95,5	113,5	135
EE	M5	M5	G1/8	G1/8	G1/8	G1/8	G1/8	G1/8	G1/4
I9	-	-	10,8	12,8	21	25,8	30	50	50
I10	-	-	-	-	-	13	18	35	50
K	8	8	10	10	13	13	17	22	22
KF	M6	M6	M8	M8	M10	M10	M12	M12	M16
KK	M8	M8	M10x1,25	M10x1,25	M12x1,25	M12x1,25	M16x1,5	M16x1,5	M20x1,5
LA	4,5	4,5	5	5	5	5	3	3	-
PL	7,5	7,5	7,5	8	8	7,5	8	10,5	10,5
RT	M5	M5	M6	M6	M8	M8	M10	M10	M12
SW2	13	13	17	17	19	19	24	24	30
TG	22	26	32,5	38	46,5	56,5	72	89	110
WH	6,5	6	6,5	7	8	8	9	10	11
WH+	6,5	6	6,5	7	8	8	9	10	11
ZA+	37	39	44	45	45	49	54	67	81
ZB+	43,5	45	50,5	52	53	57	63	77	92

+ = aggiungere lunghezza corsa (mm) - add stroke length (mm)

 Note: dado stelo compreso nella fornitura
 Note: rod nut included in the supply

OPZIONE V (FEMMINA) - Z (MASCIO) - OPTION V (FEMALE) - Z (MALE)									
Ø	020	025	032	040	050	063	080	100	
A	16	22	22	24	32	32	40	40	
AF	11	15	15	15	16	16	17	20	
Ø D	10	10	12	16	20	20	25	25	
K	8	8	10	13	17	17	22	22	
KF	M5	M6	M6	M6	M8	M8	M10	M12	
KK	M8	M10x1,25	M10x1,25	M12x1,25	M16x1,5	M16x1,5	M20x1,5	M20x1,5	

Ø	CORSE STANDARD - STANDARD STROKES								
020	5 - 10 - 15 - 20 - 25 - 30 - 40 - 50 - 60 - 70 - 75 - 80 - 90 - 100 - 125 - 160 - 200 - 250								
025	5 - 10 - 15 - 20 - 25 - 30 - 40 - 50 - 60 - 70 - 75 - 80 - 90 - 100 - 125 - 160 - 200 - 250								
032	5 - 10 - 15 - 20 - 25 - 30 - 40 - 50 - 60 - 70 - 75 - 80 - 90 - 100 - 125 - 160 - 200 - 250 - 300 - 350 - 400								
040	5 - 10 - 15 - 20 - 25 - 30 - 40 - 50 - 60 - 70 - 75 - 80 - 90 - 100 - 125 - 160 - 200 - 250 - 300 - 350 - 400								
050	5 - 10 - 15 - 20 - 25 - 30 - 40 - 50 - 60 - 70 - 75 - 80 - 90 - 100 - 125 - 160 - 200 - 250 - 300 - 350 - 400								
063	5 - 10 - 15 - 20 - 25 - 30 - 40 - 50 - 60 - 70 - 75 - 80 - 90 - 100 - 125 - 160 - 200 - 250 - 300 - 350 - 400								
080	5 - 10 - 15 - 20 - 25 - 30 - 40 - 50 - 60 - 70 - 75 - 80 - 90 - 100 - 125 - 160 - 200 - 250 - 300 - 350 - 400								
100	5 - 10 - 15 - 20 - 25 - 30 - 40 - 50 - 60 - 70 - 75 - 80 - 90 - 100 - 125 - 160 - 200 - 250 - 300 - 350 - 400								
125	5 - 10 - 15 - 20 - 25 - 30 - 40 - 50 - 60 - 70 - 75 - 80 - 90 - 100 - 125 - 160 - 200 - 250 - 300 - 350 - 400								

DOPPIO EFFETTO MAGNETICO STELO PASSANTE ANTIROTAZIONE

DOUBLE ACTING MAGNETIC ANTI-ROTATION WITH DOUBLE ROD

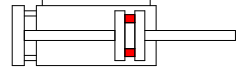

SERIE
P

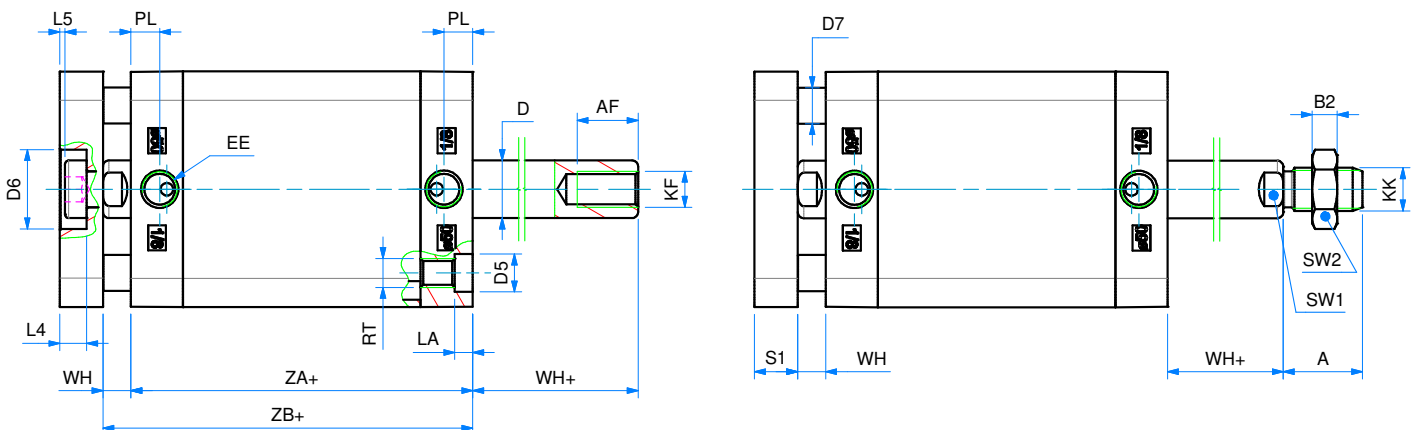
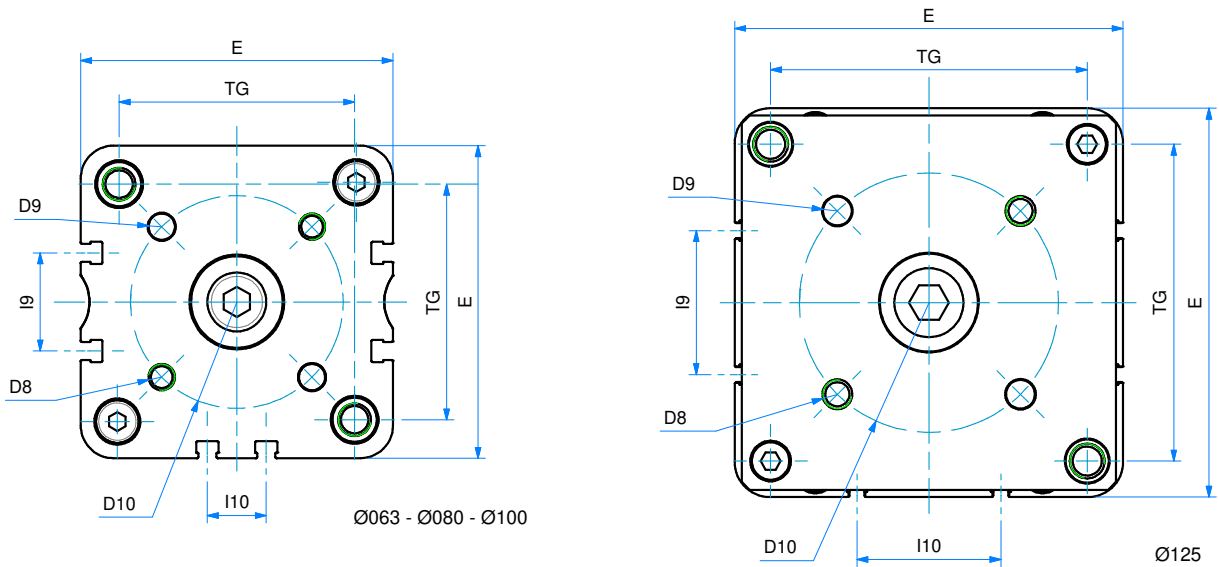
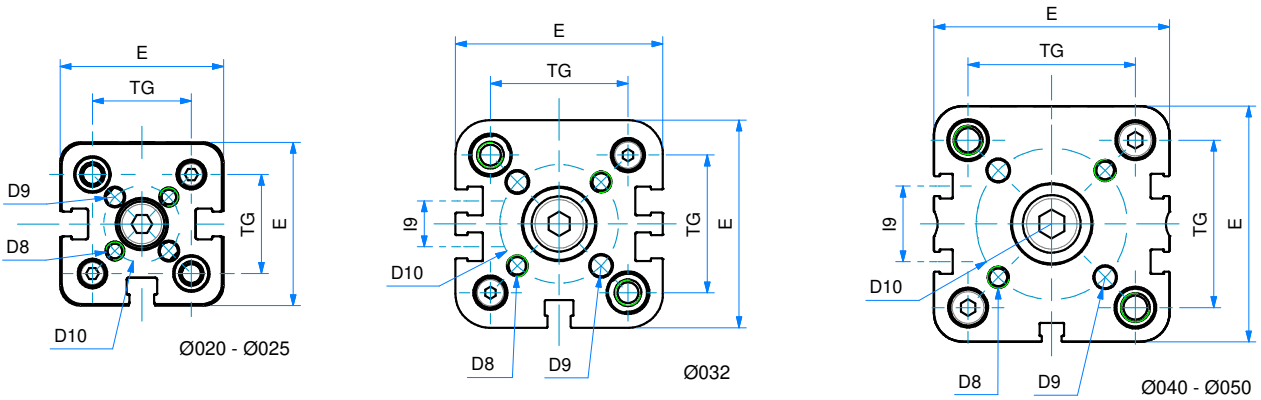

DOPPIO EFFETTO MAGNETICO STELO PASSANTE ANTIROTAZIONE
DOUBLE ACTING MAGNETIC ANTI-ROTATION WITH DOUBLE ROD

wDIMENSIONI - DIMENSIONS									
ø	020	025	032	040	050	063	080	100	125
A	16	16	19	19	22	22	28	28	40
AF	15	15	15	15	17	17	20	22	25
B2	5	5	6	6	7	7	8	8	9
ø D	10	10	12	12	16	16	20	25	25
ø D5	7,5	7,5	9	9	10,5	10,5	13,5	13,5	13,5
ø D6	11	14	17	17	22	22	28	30	34
ø D7	5	6	6	8	10	10	14	14	14
D8	M4	M5	M5	M5	M6	M6	M8	M10	M10
ø D9	4	5	5	5	6	6	8	10	10
ø D10	17	22	28	33	42	50	65	80	90
E	36	40	49	54,5	65,5	77,0	95,5	113,5	135
EE	M5	M5	G1/8	G1/8	G1/8	G1/8	G1/8	G1/8	G1/4
I9	-	-	10,8	12,8	21	25,8	30	50	50
I10	-	-	-	-	-	13	18	35	50
K	8	8	10	10	13	13	17	22	22
KF	M6	M6	M8	M8	M10	M10	M12	M12	M16
KK	M8	M8	M10x1,25	M10x1,25	M12x1,25	M12x1,25	M16x1,5	M16x1,5	M20x1,5
LA	4,5	4,5	5	5	5	5	3	3	-
L4	5	5	6,5	6,5	7,5	7,5	9	10	11,2
L5	1	1	1,5	1,5	1,5	1,5	2	3	2,2
PL	7,5	7,5	7,5	8	8	7,5	8	10,5	10,5
RT	M5	M5	M6	M6	M8	M8	M10	M10	M12
S1	8	8	10	10	12	12	14	14	18
SW2	13	13	17	17	19	19	24	24	30
TG	22	26	32,5	38	46,5	56,5	72	89	110
WH	6,5	6	6,5	7	8	8	9	10	11
WH+	6,5	6	6,5	7	8	8	9	10	11
ZA+	37	39	44	45	45	49	54	67	81
ZB+	43,5	45	50,5	52	53	57	63	77	92

+ = aggiungere lunghezza corsa (mm) - add stroke length (mm)

Note: dado stelo compreso nella fornitura
Note: rod nut included in the supply

ø	CORSE STANDARD - STANDARD STROKES
020	5 - 10 - 15 - 20 - 25 - 30 - 40 - 50 - 60 - 70 - 75 - 80 - 90 - 100 - 125 - 160 - 200
025	5 - 10 - 15 - 20 - 25 - 30 - 40 - 50 - 60 - 70 - 75 - 80 - 90 - 100 - 125 - 160 - 200
032	5 - 10 - 15 - 20 - 25 - 30 - 40 - 50 - 60 - 70 - 75 - 80 - 90 - 100 - 125 - 160 - 200 - 250 - 300 - 350 - 400
040	5 - 10 - 15 - 20 - 25 - 30 - 40 - 50 - 60 - 70 - 75 - 80 - 90 - 100 - 125 - 160 - 200 - 250 - 300 - 350 - 400
050	5 - 10 - 15 - 20 - 25 - 30 - 40 - 50 - 60 - 70 - 75 - 80 - 90 - 100 - 125 - 160 - 200 - 250 - 300 - 350 - 400
063	5 - 10 - 15 - 20 - 25 - 30 - 40 - 50 - 60 - 70 - 75 - 80 - 90 - 100 - 125 - 160 - 200 - 250 - 300 - 350 - 400
080	5 - 10 - 15 - 20 - 25 - 30 - 40 - 50 - 60 - 70 - 75 - 80 - 90 - 100 - 125 - 160 - 200 - 250 - 300 - 350 - 400
100	5 - 10 - 15 - 20 - 25 - 30 - 40 - 50 - 60 - 70 - 75 - 80 - 90 - 100 - 125 - 160 - 200 - 250 - 300 - 350 - 400
125	5 - 10 - 15 - 20 - 25 - 30 - 40 - 50 - 60 - 70 - 75 - 80 - 90 - 100 - 125 - 160 - 200 - 250 - 300 - 350 - 400

DOPPIO EFFETTO MAGNETICO

DOUBLE ACTING MAGNETIC

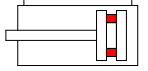

SERIE
P

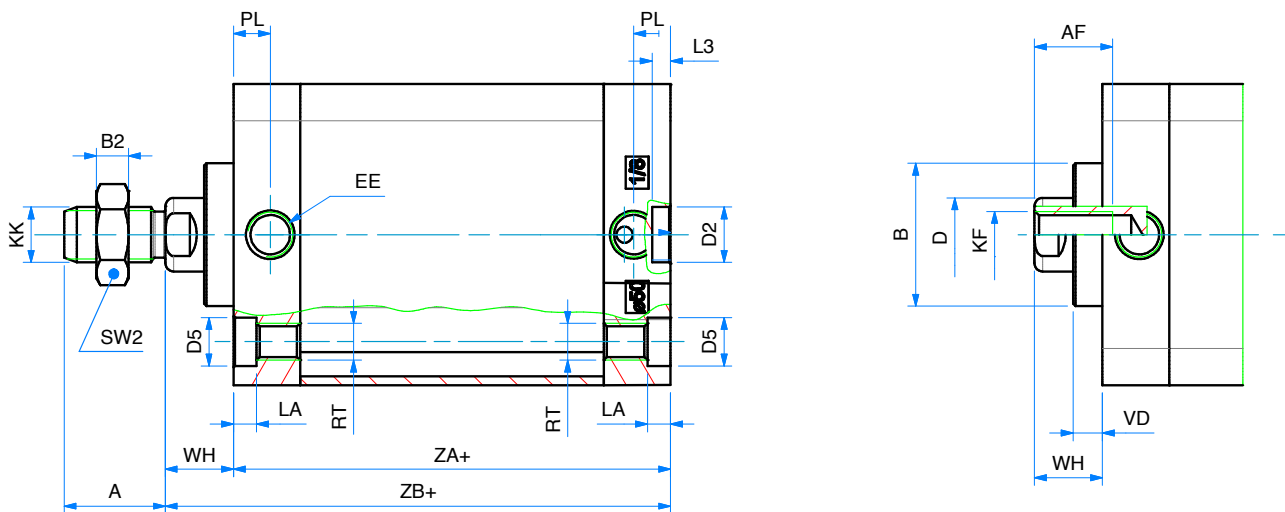
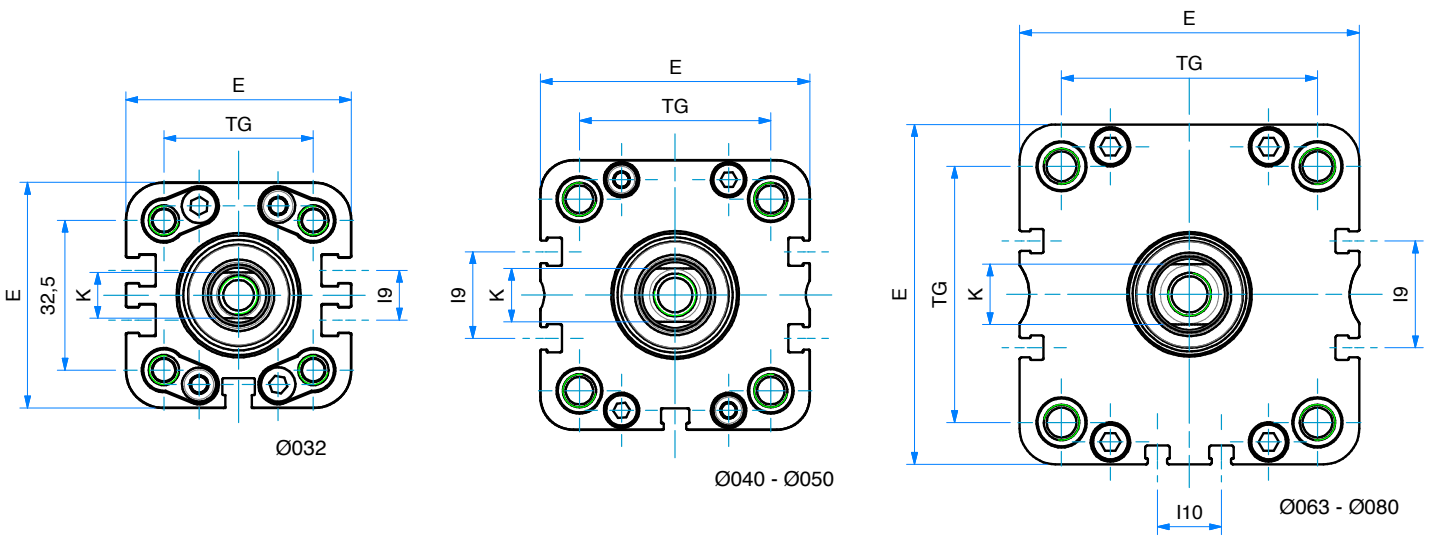

DOPPIO EFFETTO MAGNETICO
DOUBLE ACTING MAGNETIC

DIMENSIONI - DIMENSIONS					
Ø	032	040	050	063	080
A	19	19	22	22	28
AF	15	15	17	17	20
Ø B	27	27	31	31	35
B2	6	6	7	7	8
Ø D	12	12	16	16	20
Ø D2	9	9	12	12	12
Ø D5	9	9	10,5	10,5	13,5
E	49	54,5	65,5	77	95,5
EE	G1/8	G1/8	G1/8	G1/8	G1/8
I9	10,8	12,8	21	25,8	30
I10	-	-	-	13	18
K	10	10	13	13	17
KF	M8	M8	M10	M10	M12
KK	M10x1,25	M10x1,25	M12x1,25	M12x1,25	M16x1,5
LA	5	5	5,5	5	3
L3	3	3	4	4	4
PL	7,5	8	8	7,5	8
RT	M6	M6	M8	M8	M10
SW2	17	17	19	19	24
TG	32,5	38	46,5	56,5	72
VD	6,4	6,4	6,4	6,4	6,4
WH	12,5	12,5	14,8	14,6	15,4
ZA+	44	45	45	49	54
ZB+	56,5	57,5	59,7	63,6	69,4

+ = aggiungere lunghezza corsa (mm) - add stroke length (mm)

 Note: dado stelo compreso nella fornitura
 Note: rod nut included in the supply

Ø	CORSE STANDARD - STANDARD STROKES
032	5 - 10 - 15 - 20 - 25 - 30 - 40 - 50 - 60 - 70 - 75 - 80 - 90 - 100 - 125 - 160 - 200 - 250 - 300 - 350 - 400
040	5 - 10 - 15 - 20 - 25 - 30 - 40 - 50 - 60 - 70 - 75 - 80 - 90 - 100 - 125 - 160 - 200 - 250 - 300 - 350 - 400
050	5 - 10 - 15 - 20 - 25 - 30 - 40 - 50 - 60 - 70 - 75 - 80 - 90 - 100 - 125 - 160 - 200 - 250 - 300 - 350 - 400
063	5 - 10 - 15 - 20 - 25 - 30 - 40 - 50 - 60 - 70 - 75 - 80 - 90 - 100 - 125 - 160 - 200 - 250 - 300 - 350 - 400
080	5 - 10 - 15 - 20 - 25 - 30 - 40 - 50 - 60 - 70 - 75 - 80 - 90 - 100 - 125 - 160 - 200 - 250 - 300 - 350 - 400

DOPPIO EFFETTO MAGNETICO CON STELO FORATO

DOUBLE ACTING MAGNETIC WITH HOLLOW ROD

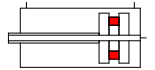

SERIE
P

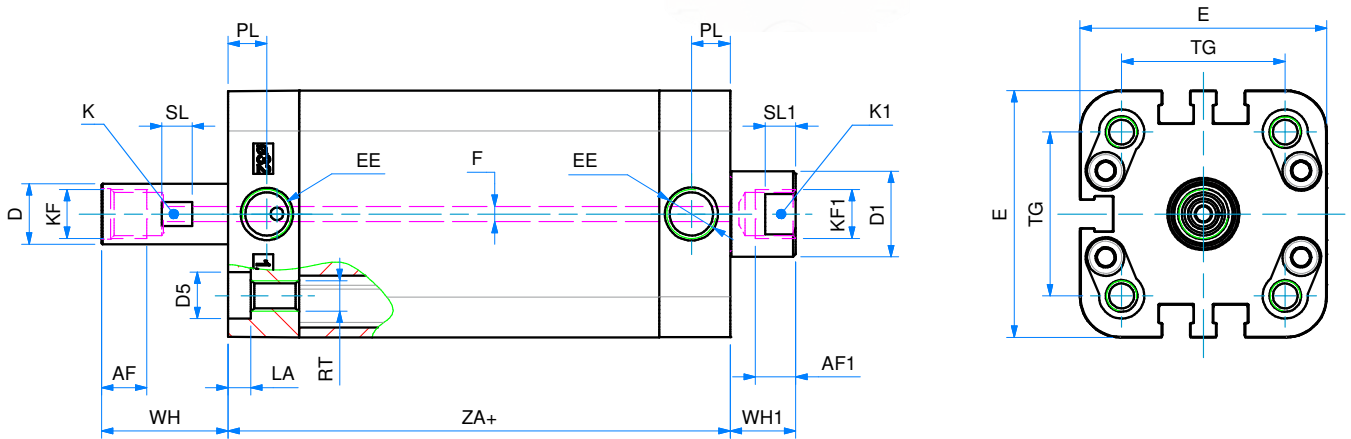

Note: stelo in acciaio inox 304 cromato

Note: chromed AISI 304 stainless steel rod

DIMENSIONI - DIMENSIONS

∅	32
AF	9
AF1	7,5
∅D	12
∅D1	17
∅D5	9
E	49
EE	G 1/8"
∅F	3
K	11
K1	15
KF	G 1/8"
KF1	G 1/8"
LA	5
PL	7,5
RT	M6
SL	6
SL1	6
TG	32,5
WH	25
WH1	13
ZA+	50

∅ CORSE STANDARD - STANDARD STROKES

032 50 - 100 - 150 - 200 - 250 - 300 - 350

+ = aggiungere lunghezza corsa (mm) - add stroke length (mm)

CILINDRI TANDEM - TANDEM CYLINDERS

CHIAVE DI CODIFICA - KEY CODE

P T2 M 0 6 3 . 1 0 0 . G S . M

VERSIONE - VERSION

- T2** tandem doppia spinta
double thrust tandem
- T3** tandem tripla spinta
3 x force
- T4** tandem quadrupla spinta
4 x force

OPZIONE - OPTION

EX ATEX  II 2GD cT4

SERIE

P

P P M 0 5 0 . 0 3 0 . 0 8 0 . G S . F

**ALESAGGIO
BORE (∅)**

020 - 025 - 032 - 040
050 - 063 - 080 - 100 - 125

**I° CORSA (mm)
I° STROKE (mm)**

vedere tabelle corse std
see std stroke tables

**II° CORSA (mm)
II° STROKE (mm)**

vedere tabelle corse std
see std stroke tables

OPZIONE - OPTION

EX ATEX  II 2GD cT4

VERSIONE - VERSION

- M** magnetico - *magnetic*
- non magnetico - *non-magnetic*

VERSIONE - VERSION

- P** tandem più posizioni
multi position tandem
- C** tandem contrapposti posteriori
rear opposed tandem
- F** tandem contrapposti anteriori
front opposed tandem

SERIE - SERIES

- P** tubo profilato con cave per sensori
tube with slots for sensors

STELO - ROD

- F** femmina
female
- M** maschio
male

GUARNIZIONI - SEALS

- GS** guarnizioni standard
standard seals
- VR** guarnizione stelo per alte temperature
high temperature rod seal
- VA** tutte le guarnizioni per alte temperature
all seals for high temperature
- PS** guarnizione stelo EU P5600
EU P5600 rod seal
- ES** guarnizione stelo E8
E8 rod seal
- WS** guarnizione stelo EW (raschiatore metallico)
EW rod seal (metal scraper)

∅32 - 80
∅50 - 80

DOPPIA SPINTA - DOUBLE THRUST

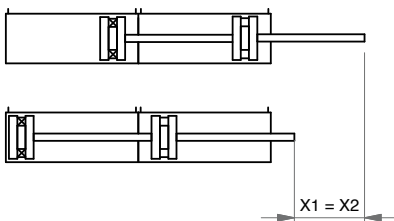

PIÙ POSIZIONI - MULTI-POSITIONS

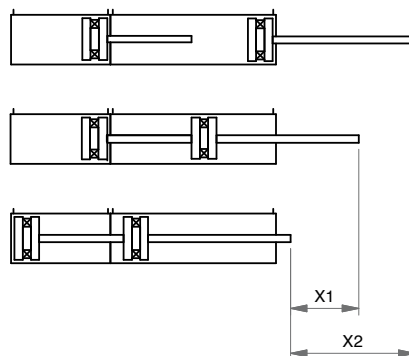

CONTRAPPOSTI POSTERIORI - REAR OPPOSED

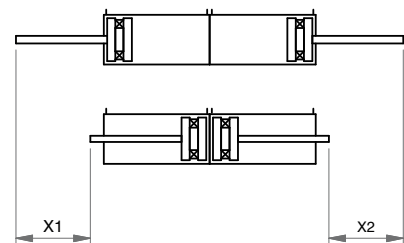

CONTRAPPOSTI ANTERIORI - FRONT OPPOSED

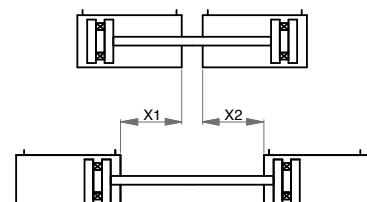

X1= 1° corsa - 1° stroke
X2= 2° corsa - 2° stroke

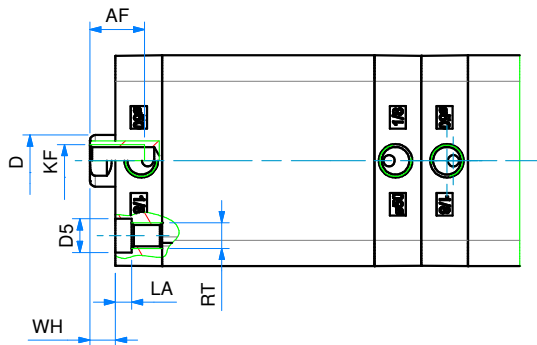
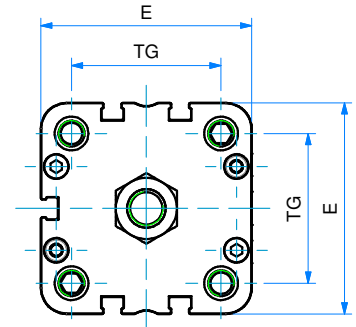
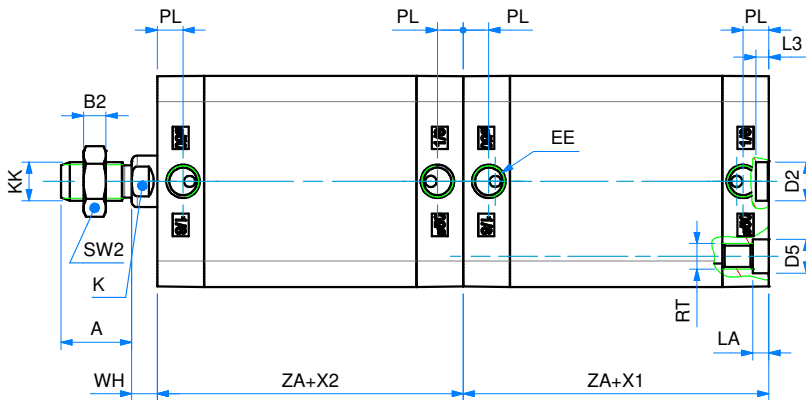
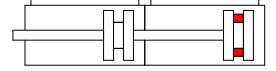
TANDEM DOPPIA SPINTA D.E.M.
DOUBLE THRUST TANDEM D.A.M.
**SERIE
P**

Note: dado stelo compreso nella fornitura
Note: rod nut included in the supply

DIMENSIONI - DIMENSIONS

ø	020	025	032	040	050	063	080	100	125
A	16	16	19	19	22	22	28	28	40
AF	15	15	15	15	17	17	20	22	25
B2	5	5	6	6	7	7	8	8	9
ø D	10	10	12	12	16	16	20	25	25
ø D2	9	9	9	9	12	12	12	12	12
ø D5	7,5	7,5	9	9	10,5	10,5	13,5	13,5	-
E	36	40	49	54,5	65,5	77	95,5	113,5	135
EE	M5	M5	G1/8	G1/8	G1/8	G1/8	G1/8	G1/8	G1/4
K	8	8	10	10	13	13	17	22	22
KF	M6	M6	M8	M8	M10	M10	M12	M12	M 16
KK	M8	M8	M10x1,25	M10x1,25	M12x1,25	M12x1,25	M16x1,5	M16x1,5	M 20x1,5
L3	3	3	3	3	4	4	4	4	4
LA	4,5	4,5	5	5	6,5	5	3	3	-
PL	7,5	7,5	7,5	8	8	7,5	8	10,5	10,5
RT	M5	M5	M6	M6	M8	M8	M10	M10	M12
SW2	13	13	17	17	19	19	24	24	30
TG	22	26	32,5	38	46,5	56,5	72	89	110
WH	6,5	6	6,5	7	8	8	9	10	11
X1	I° CORSA - I° STROKE								
X2	II° CORSA - II° STROKE								
ZA	37	39	44	45	45	49	54	67	81

TANDEM PIÙ POSIZIONI D.E.M.

MULTI-POSITION TANDEM D.A.M.

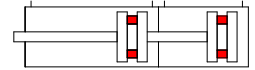

SERIE

P

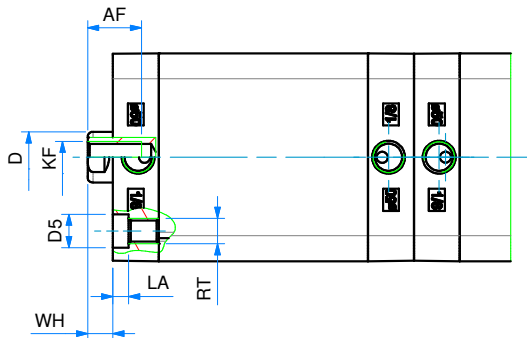
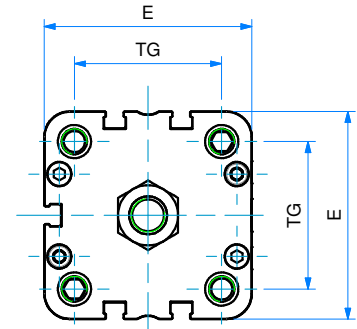
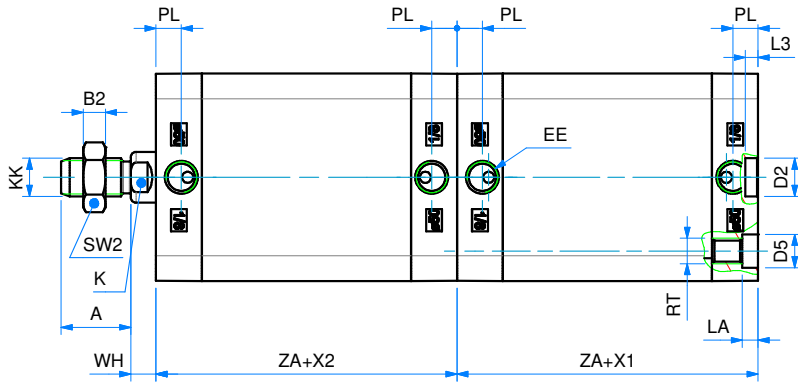

Note: dado stelo compreso nella fornitura
 Note: rod nut included in the supply

DIMENSIONI - DIMENSIONS

ø	020	025	032	040	050	063	080	100	125
A	16	16	19	19	22	22	28	28	40
AF	15	15	15	15	17	17	20	22	25
B2	5	5	6	6	7	7	8	8	9
ø D	10	10	12	12	16	16	20	25	25
ø D2	9	9	9	9	12	12	12	12	12
ø D5	7,5	7,5	9	9	10,5	10,5	13,5	13,5	-
E	36	40	49	54,5	65,5	77	95,5	113,5	135
EE	M5	M5	G1/8	G1/8	G1/8	G1/8	G1/8	G1/8	G1/4
K	8	8	10	10	13	13	17	22	22
KF	M6	M6	M8	M8	M10	M10	M12	M12	M 16
KK	M8	M8	M10x1,25	M10x1,25	M12x1,25	M12x1,25	M16x1,5	M16x1,5	M 20x1,5
L3	3	3	3	3	4	4	4	4	4
LA	4,5	4,5	5	5	6,5	5	3	3	-
PL	7,5	7,5	7,5	8	8	7,5	8	10,5	10,5
RT	M5	M5	M6	M6	M8	M8	M10	M10	M12
SW2	13	13	17	17	19	19	24	24	30
TG	22	26	32,5	38	46,5	56,5	72	89	110
WH	6,5	6	6,5	7	8	8	9	10	11
X1	I° CORSA - I° STROKE								
X2	II° CORSA - II° STROKE								
ZA	37	39	44	45	45	49	54	67	81

TANDEM CONTRAPPOSTI POSTERIORI D.E.M.

REAR OPPOSED TANDEM D.A.M.

SERIE

P

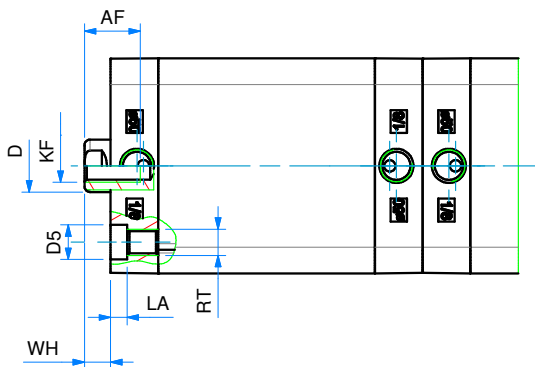
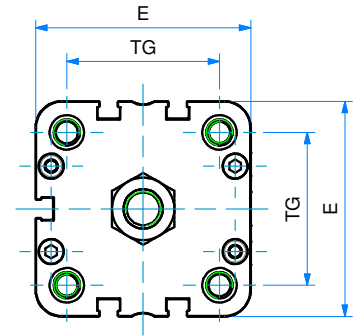
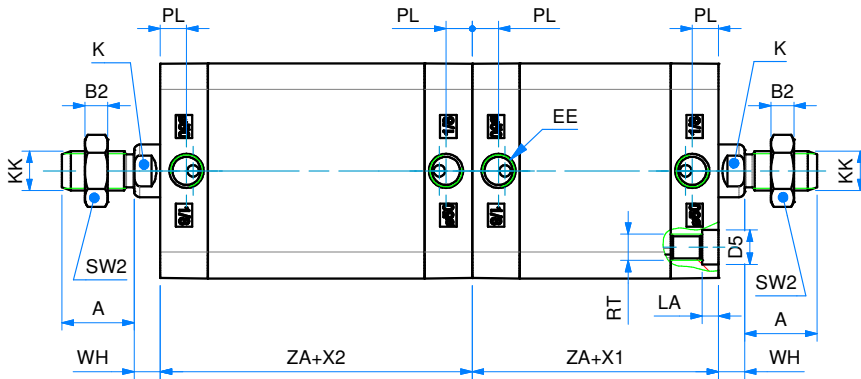
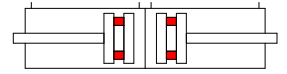

Note: dado stelo compreso nella fornitura
 Note: rod nut included in the supply

DIMENSIONI - DIMENSIONS

∅	020	025	032	040	050	063	080	100	125
A	16	16	19	19	22	22	28	28	40
AF	15	15	15	15	17	17	20	22	25
B2	5	5	6	6	7	7	8	8	9
∅ D	10	10	12	12	16	16	20	25	25
∅ D2	9	9	9	9	12	12	12	12	12
∅ D5	7,5	7,5	9	9	10,5	10,5	13,5	13,5	-
E	36	40	49	54,5	65,5	77	95,5	113,5	135
EE	M5	M5	G1/8	G1/8	G1/8	G1/8	G1/8	G1/8	G1/4
K	8	8	10	10	13	13	17	22	22
KF	M6	M6	M8	M8	M10	M10	M12	M12	M 16
KK	M8	M8	M10x1,25	M10x1,25	M12x1,25	M12x1,25	M16x1,5	M16x1,5	M 20x1,5
L3	3	3	3	3	4	4	4	4	4
LA	4,5	4,5	5	5	6,5	5	3	3	-
PL	7,5	7,5	7,5	8	8	7,5	8	10,5	10,5
RT	M5	M5	M6	M6	M8	M8	M10	M10	M12
SW2	13	13	17	17	19	19	24	24	30
TG	22	26	32,5	38	46,5	56,5	72	89	110
WH	6,5	6	6,5	7	8	8	9	10	11
X1	I° CORSA - I° STROKE								
X2	II° CORSA - II° STROKE								
ZA	37	39	44	45	45	49	54	67	81

TANDEM CONTRAPPOSTI ANTERIORI D.E.M.

FRONT OPPOSED TANDEM D.A.M.

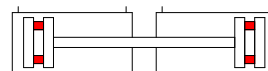

SERIE

P

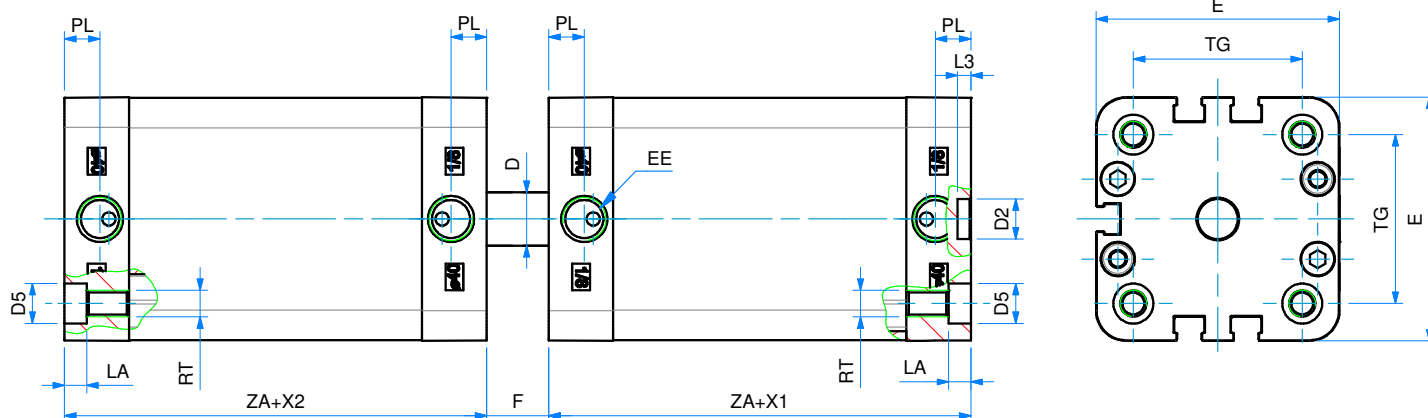

DIMENSIONI - DIMENSIONS

ø	20	25	32	40	50	63	80	100	125
ø D	10	10	12	12	16	16	20	25	25
ø D2	9	9	9	9	12	12	12	12	12
ø D5	7,5	7,5	9	9	10,5	10,5	13,5	13,5	-
E	36	40	49	54,5	65,5	77	95,5	113,5	135
EE	M5	M5	G1/8	G1/8	G1/8	G1/8	G1/8	G1/8	G1/4
F	13	12	13	14	16	16	18	20	22
L3	3	3	3	3	4	4	4	4	4
LA	4,5	4,5	5	5	5	5	3	3	-
PL	7,5	7,5	7,5	8	8	7,5	8	10,5	10,5
RT	M5	M5	M6	M6	M8	M8	M10	M10	M12
TG	22	26	32,5	38	46,5	56,5	72	89	110
X1	I° CORSA - I° STROKE								
X2	II° CORSA - II° STROKE								
ZA	37	39	44	45	45	49	54	67	81

ACCESSORI DI FISSAGGIO ISO 15552 (UTILIZZABILI ANCHE PER CILINDRI ISO 21287)

ISO 15552 MOUNTING PARTS (ALSO SUITABLE FOR ISO 21287 CYLINDERS)

SERIE
P

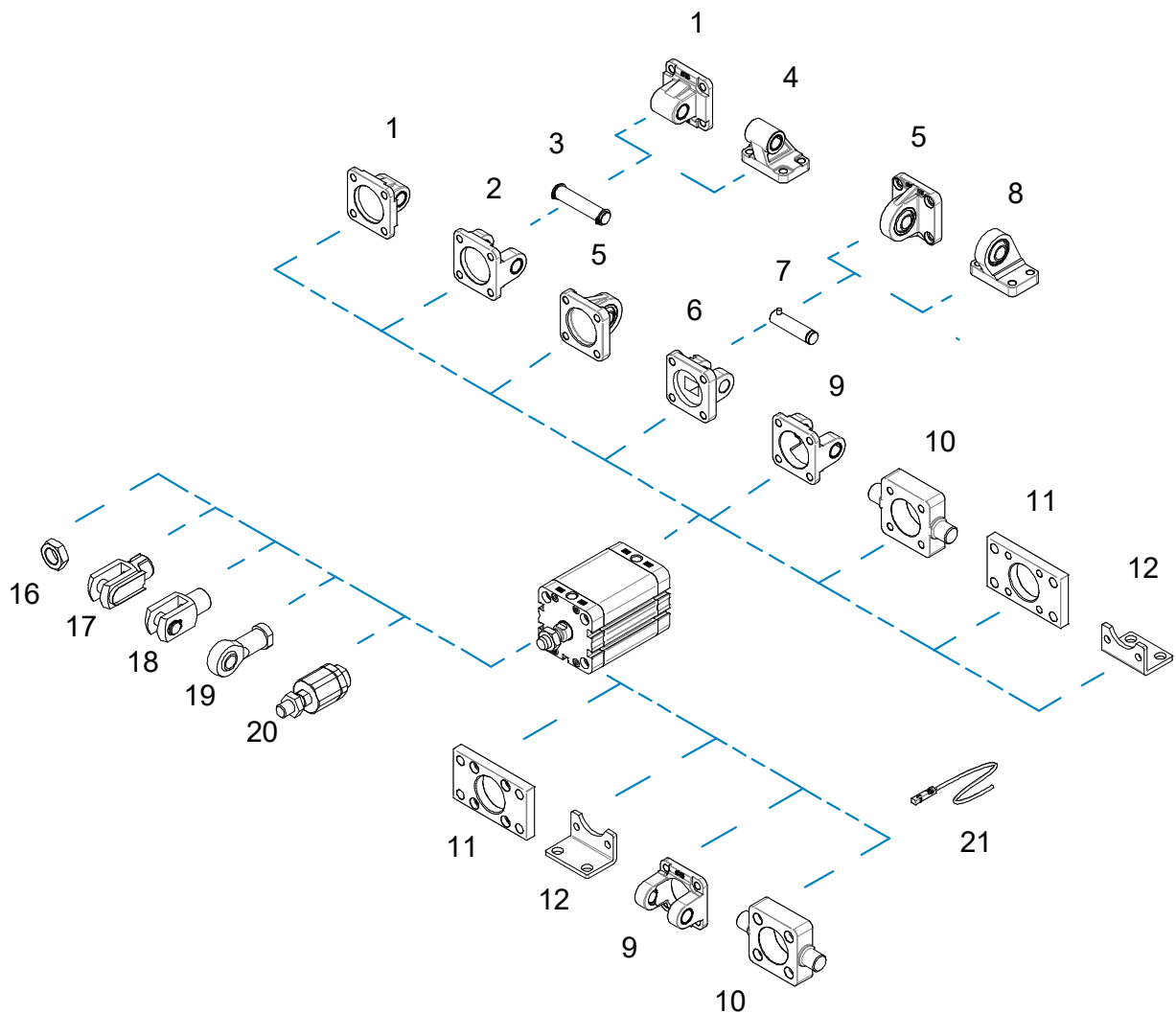

POS.	CODE	DESCRIZIONE-DESCRIPTION
1	CMI---	cerniera maschio iso - iso male hinge
2	CFI---	cerniera femmina iso - iso female hinge
3	PCF---	perno per cerniera - pin for hinge
4	ASI---	articolazione a squadra iso - iso square hinge
5	CMSI---	cerniera maschio snodata iso iso male hinge with ball joint
6	CFSI---	cerniera femmina stretta iso iso narrow female hinge
7	PCFS---	perno per cerniera stretta pin for narrow hinge
8	ASSI---	articolazione a squadra snodata iso square hinge with ball joint
9	CFI--F	cerniera femmina forata iso hollow iso female hinge
10	CIA---	cerniera anteriore-posteriore lamata front-rear hinge
11	FI---	flangia iso - iso flange
12	PBI---	piedino basso iso - iso foot mounting

POS.	CODE	DESCRIZIONE-DESCRIPTION
16	DA--x---	dado - nut
17	FC--x---	forcella con clips - clevis with lockable pin
18	FP--x---	forcella con perno - clevis with pin
19	SSFI--x---	snodo sferico - rod eye
20	SA--x---	snodo autoallineante - self-aligning joint
21	36.SEN---	sensore magnetico - magnetic sensor

Fissaggi forniti con viti - Mounting parts supplied with screws

CERNIERA MASCHIO ISO (MP4)

ISO MALE HINGE (MP4)

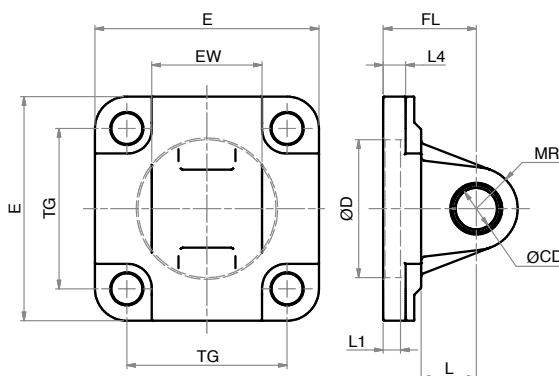

LA FORNITURA COMPRENDE:
n° 1 CERNIERA MASCHIO
n° 4 VITI
THE SUPPLY INCLUDES:
n° 1 MALE HINGE
n° 4 SCREWS

MATERIALE:
CORPO IN ALLUMINIO
BOCCOLA IN ACCIAIO E PTFE
MATERIAL:
BODY IN ALUMINIUM
BUSH IN STEEL AND PTFE

SERIE

P

DIMENSIONI - DIMENSIONS

COD.	CMI016	CMI020	CMI025	CMI032	CMI040	CMI050	CMI063	CMI080	CMI100	CMI125
Ø	16	20	25	32	40	50	63	80	100	125
EW	12	16	16	26	28	32	40	50	60	70
E	27	34	38	45	52	65	75	93	110	134
FL	16	20	20	22	25	27	32	36	41	50
L1	-	3	3	5	5	5	5	5	5	7
L4	3,4	2,7	2,7	5,5	5,5	6,5	6,5	10	10	10
L	10	14	14	13	16	16	21	22	27	30
MR	6	8	8	10	12	12	16	16	20	25
Ø CD	6	8	8	10	12	12	16	16	20	25
Ø D	-	12	12	30	35	40	45	45	55	60
TG	18	22	26	32,5	38	46,5	56,5	72	89	110

CERNIERA FEMMINA ISO (MP2)

CFI

CFI-F*

ISO FEMALE HINGE (MP2)

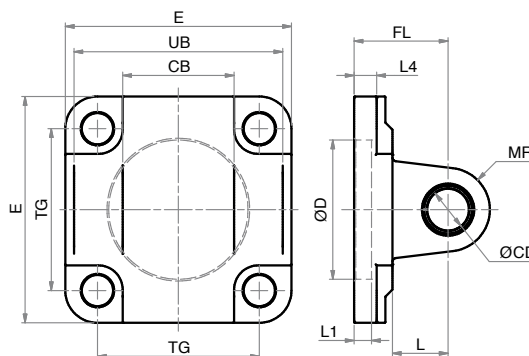

LA FORNITURA COMPRENDE:
n° 1 CERNIERA FEMMINA
n° 4 VITI
THE SUPPLY INCLUDES:
n° 1 FEMALE HINGE
n° 4 SCREWS

MATERIALE:
CORPO IN ALLUMINIO
BOCCOLA IN ACCIAIO E PTFE
MATERIAL:
BODY IN ALUMINIUM
BUSH IN STEEL AND PTFE

DIMENSIONI - DIMENSIONS

COD.	CFI032	CFI040	CFI050	CFI063	CFI080	CFI100	CFI125
Ø	32	40	50	63	80	100	125
CB	26	28	32	40	50	60	70
E	45	52	65	75	93	110	134
FL	22	25	27	32	36	41	50
L1	5	5	5	5	5	5	7
L4	5,5	5,5	6,5	6,5	10	10	10
L	13	16	16	21	22	27	30
MR	10	12	12	16	16	20	25
Ø CD	10	12	12	16	16	20	25
Ø D	30	35	40	45	45	55	60
TG	32,5	38	46,5	56,5	72	89	110
UB	45	52	60	70	90	110	130

*CFI---F dimensione foro centrale uguale alla quota ØD - *CFI---F dimension of the central hole are the same as ØD

PERNO PER CERNIERA (AA4)

PIN FOR HINGE (AA4)

SERIE
P

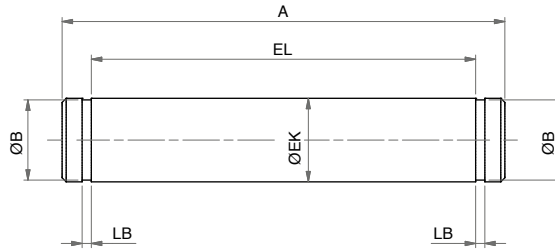

LA FORNITURA COMPRENDE:
n°1 PERNO
n°2 SEEGER
THE SUPPLY INCLUDES:
n°1 PIN
n°2 RETAINING RING

MATERIALE:
ACCIAIO ZINCATO
MATERIAL:
ZINC COATED STEEL

DIMENSIONI - DIMENSIONS

COD.	PCF032	PCF040	PCF050	PCF063	PCF080	PCF100	PCF125
Ø	32	40	50	63	80	100	125
A	53	60	68	78	98	118	139
EL	46	53	61	71	91	111	132
LB	1,1	1,1	1,1	1,1	1,1	1,3	1,3
Ø B	9,6	11,5	11,5	15,2	15,2	19	23,9
Ø EK	10	12	12	16	16	20	25

ARTICOLAZIONE A SQUADRA ISO (AB7)

ISO SQUARE HINGE (AB7)

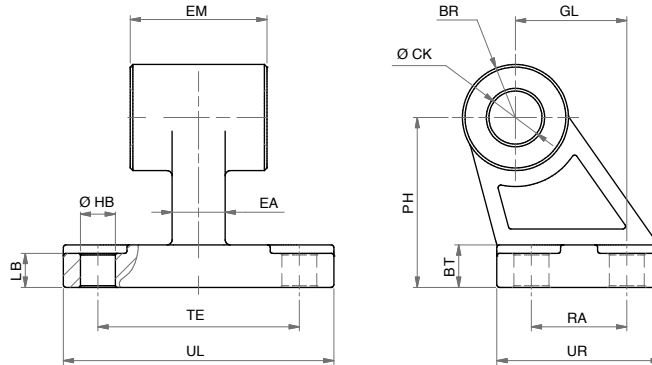

LA FORNITURA COMPRENDE:
n°1 ARTICOLAZIONE A SQUADRA
THE SUPPLY INCLUDES:
n°1 SQUARE HINGE

MATERIALE:
CORPO IN ALLUMINIO
BOCCOLA IN ACCIAIO E PTFE
MATERIAL:
BODY IN ALUMINIUM
BUSH IN STEEL AND PTFE

DIMENSIONI - DIMENSIONS

COD.	ASI032	ASI040	ASI050	ASI063	ASI080	ASI100	ASI125
Ø	32	40	50	63	80	100	125
BR	10	11	13	15	15	19	22,5
BT	8	10	12	14	14	17	20
Ø CK	10	12	12	16	16	20	25
EA	10	15	16	16	20	20	30
EM	26	28	32	40	50	60	70
GL	21	24	33	37	47	55	70
LB	6,4	8,4	10,4	12,4	11,5	14,5	16,8
Ø HB	6,6	6,6	9	9	11	11	14
PH	32	36	45	50	63	71	90
RA	18	22	30	35	40	50	60
TE	38	41	50	52	66	76	94
UL	51	54	65	67	86	96	124
UR	31	35	45	50	60	70	90

CERNIERA MASCHIO SNODATA ISO (MP6)

ISO MALE HINGE WITH BALL JOINT (MP6)

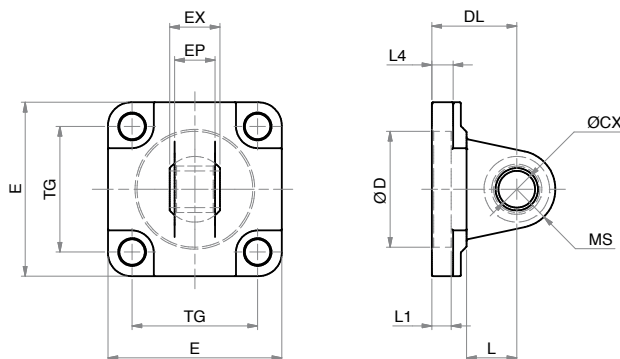

LA FORNITURA COMPRENDE:
n° 1 CERNIERA MASCHIO
n° 4 VITI
THE SUPPLY INCLUDES:
n° 1 MALE HINGE
n° 4 SCREWS

MATERIALE:
CORPO IN ALLUMINIO
SNODO IN ACCIAIO,
BRONZO E PTFE
MATERIAL:
BODY IN ALUMINIUM
EYE IN STEEL, BRONZE AND PTFE

SERIE

P

DIMENSIONI - DIMENSIONS

COD.	CMSI032	CMSI040	CMSI050	CMSI063	CMSI080	CMSI100	CMSI125
Ø	32	40	50	63	80	100	125
DL	22	25	27	32	36	41	50
EP	10,5	12	15	15	18	18	25
EX	14	16	21	21	25	25	37
E	45	52	65	75	95	115	140
L1	7	7	7	7	9	9	9
L4	5,5	5,5	6,5	6,5	10	10	10
L	12	15	15	20	20	25	30
MS	16	18	21	23	28	30	40
ØCX	10	12	16	16	20	20	30
ØD	30	35	40	45	45	55	60
TG	32,5	38	46,5	56,5	72	89	110

ARTICOLAZIONE A SQUADRA SNODATA

ISO SQUARE HINGE WITH BALL JOINT

ASSI

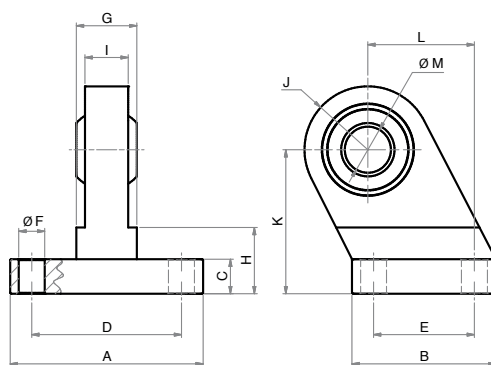

LA FORNITURA COMPRENDE:
n° 1 ARTICOLAZIONE A SQUADRA
THE SUPPLY INCLUDES:
n° 1 SQUARE HINGE

MATERIALE:
CORPO IN ALLUMINIO
SNODO IN ACCIAIO,
BRONZO E PTFE
MATERIAL:
BODY IN ALUMINIUM
EYE IN STEEL, BRONZE AND PTFE

DIMENSIONI - DIMENSIONS

COD.	ASSI032	ASSI040	ASSI050	ASSI063	ASSI080	ASSI100
Ø	32	40	50	63	80	100
A	51	54	65	67	86	96
B	31	35	45	50	60	70
C	10	10	12	12	14	15
D	38	41	50	52	66	76
E	18	22	30	35	40	50
G	14	16	21	21	25	25
H	16	16	21	23	32	33
I	10,5	12	15	15	18	18
J	15	17	20	22	27	29
K	32	36	45	50	63	71
L	21	24	33	37	47	55
ØF	6,6	6,6	9	9	11	11
ØM	10	12	16	16	20	20

CERNIERA FEMMINA STRETTA ISO (AB6)

ISO NARROW FEMALE HINGE (AB6)

SERIE
P

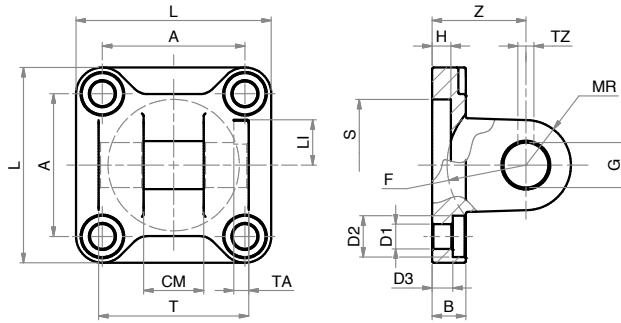
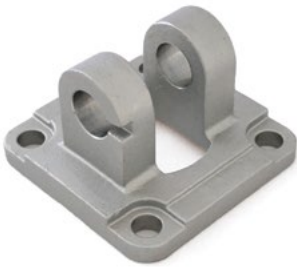

LA FORNITURA COMPRENDE:
n° 1 CERNIERA FEMMINA
n° 4 VITI
THE SUPPLY INCLUDES:
n° 1 FEMALE HINGE
n° 4 SCREWS

MATERIALE: ALLUMINO
MATERIAL: ALUMINIUM

DIMENSIONI - DIMENSIONS

COD.	CFSI032	CFSI040	CFSI050	CFSI063	CFSI080	CFSI100	CFSI125
ø	32	40	50	63	80	100	125
A	32,5	38	46,5	56,5	72	89	110
B	9	9	11	11	14	14	20
CM	14	16	21	21	25	25	37
D1	6,6	6,6	9	9	11	11	14
D2	11	11	15	15	18	18	20
D3	5,5	5,5	6,5	6,5	10	10	10
F min.	17	20	22	25	30	32	42
G	10	12	16	16	20	20	30
H	5	5	5	5	5	5	7
LI	11,5	12	14	14	16	16	24
L	45	52	65	75	95	115	140
MR	10	12	14	18	20	22	25
S	30	35	40	45	45	55	60
TA	3	4	4	4	4	4	6
TZ	3,3	4,3	4,3	4,3	4,3	6,3	6,3
T	34	40	45	51	65	75	97
Z	22	25	27	32	36	41	50

PERNO PER CERNIERA STRETTA (AA6)

PIN FOR NARROW HINGE (AA6)

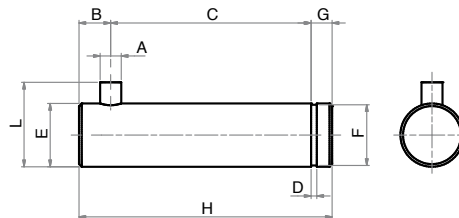

LA FORNITURA COMPRENDE:
n° 1 PERNO
n° 1 SEEGER
THE SUPPLY INCLUDES:
n° 1 PIN
n° 1 RETAINING RING

MATERIALE:
ACCIAIO ZINCATO
MATERIAL:
ZINC COATED STEEL

DIMENSIONI - DIMENSIONS

COD.	PCFS032	PCFS040	PCFS050	PCFS063	PCFS080	PCFS100	PCFS125
ø	32	40	50	63	80	100	125
A	3	4	4	4	4	4	6
B	4,5	6	6	6	6	6	9
C	32,5	38	43	49	63	73	94
D	1,1	1,1	1,1	1,1	1,3	1,3	1,6
E	10	12	16	16	20	20	30
F	9,6	11,5	15,2	15,2	19	19	28,6
G	4	4	5	5	6	6	7
H	41	48	54	60	75	85	110
L	14	16	20	20	24	24	36

PIEDINO BASSO ISO (MS1)

ISO FOOT MOUNTING (MS1)

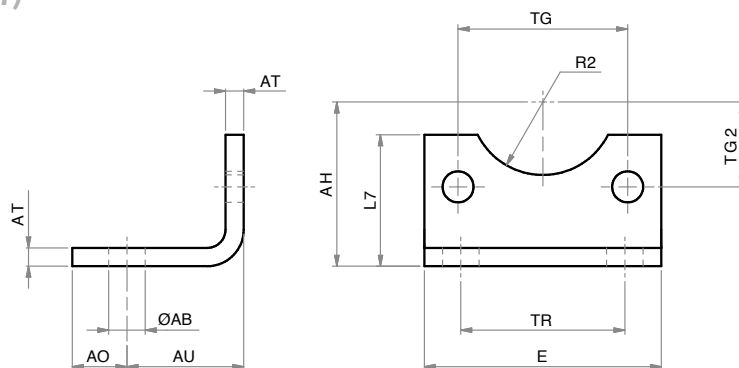

LA FORNITURA COMPRENDE:
n° 1 PIEDINO
n° 2 VITI
THE SUPPLY INCLUDES:
n° 1 FOOT MOUNTING
n° 2 SCREWS

MATERIALE:
ACCIAIO ZINCATO
MATERIAL:
ZINC COATED STEEL

SERIE

P

DIMENSIONI - DIMENSIONS

COD.	PBI032	PBI040	PBI050	PBI063	PBI080	PBI100	PBI125
ø	32	40	50	63	80	100	125
AH	32	36	45	50	63	71	90
AO	11	8	15	13	14	16	25
AT	4	4	5	5	6	6	8
AU	24	28	32	32	41	41	45
E	45	52	65	75	95	115	140
L7	30	30	36	35	47	53	70
ø AB	7	10	10	10	12	14,5	16,5
R2	15	17,5	20	22,5	22,5	27,5	30
TG2	16,25	19	23,25	28,25	36	44,5	55
TG	32,5	38	46,5	56,5	72	89	110
TR	32	36	45	50	63	75	90

A richiesta - On request ø 250-320

FLANGIA ISO (MF1 - MF2)

ISO FLANGE (MF1 - MF2)

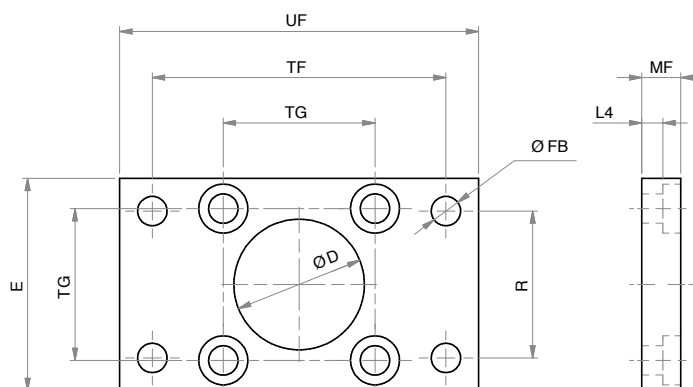

LA FORNITURA COMPRENDE:
n° 1 FLANGIA
n° 4 VITI
THE SUPPLY INCLUDES:
n° 1 FLANGE
n° 4 SCREWS

MATERIALE:
ACCIAIO ZINCATO
MATERIAL:
ZINC COATED STEEL

DIMENSIONI - DIMENSIONS

COD.	FI032	FI040	FI050	FI063	FI080	FI100	FI125
ø	32	40	50	63	80	100	125
E	45	52	65	75	95	115	140
L4	5	5	6,5	6,5	9	9	10,5
MF	10	10	12	12	16	16	20
ø D	30	35	40	45	45	55	60
ø FB	7	9	9	9	12	14	16
R	32	36	45	50	63	75	90
TF	64	72	90	100	126	150	180
TG	32,5	38	46,5	56,5	72	89	110
UF	80	90	110	120	150	170	205

DADO STELO
PISTON ROD NUT

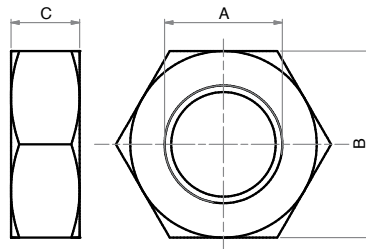
 SERIE
P

 MATERIALE:
 ACCIAIO ZINCATO
 MATERIAL:
 ZINC COATED STEEL

DIMENSIONI - DIMENSIONS

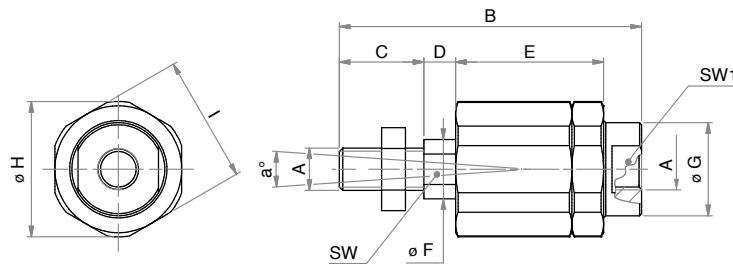
COD.	DA06x1	DA08x1,25	DA10x1,25	DA12x1,25	DA16x1,5	DA20x1,5
A	M6	M8	M10x1,25	M12x1,25	M16x1,5	M20x1,5
B	10	13	17	19	24	30
C	4	5	6	7	8	9

SNODO AUTOALLINEANTE
SELF-ALIGNING COUPLING

 LA FORNITURA
 COMPRENDE:
 n° 1 SNODO
 AUTOALLINEANTE
 n° 1 DADO
 THE SUPPLY INCLUDES:
 n° 1 SELF ALIGNING
 n° 1 NUT

 MATERIALE:
 ACCIAIO ZINCATO
 MATERIAL:
 ZINC COATED STEEL

DIMENSIONI - DIMENSIONS

COD.	SA06x1	SA08x1,25	SA10x1,25	SA12x1,25	SA16x1,5	SA20x1,5
A	M6x1	M8x1,25	M10x1,25	M12x1,25	M16x1,5	M20x1,5
α°	8	8	8	8	8	8
B	37	50	71	74,5	104	120
C	12	16	20	24	32	40
D	2,5	4	7	7,5	7	8
E	17,5	23,5	36	36	53	53
ø F	6	8	14	14	22	22
ø G	8,5	12,5	21,5	21,5	34	34
ø H	14,5	19	32	32	45	45
I	13	17	30	30	41	41
SW	5	7	12	12	19	19
SW1	7	10	19	19	30	30

SNODO SFERICO FILETTO INTERNO

ROD EYE (INTERNAL THREAD)

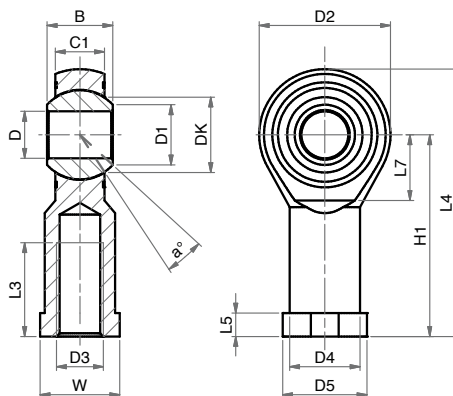

MATERIALE:
CORPO IN ACCIAIO ZINCATO
SNODO IN ACCIAIO,
BRONZO E PTFE
MATERIAL:
BODY IN ZINC COATED STEEL
EYE IN STEEL, BRONZE
AND PTFE

SERIE

P

DIMENSIONI - DIMENSIONS

COD.	SSFI06x1	SSFI08x1,25	SSFI10x1,25	SSFI12x1,25	SSFI16x1,5	SSFI20x1,5
α°	13	14	13	13	15	14
B	9	12	14	16	21	25
C1	6,75	9	10,5	12	15	18
D1	8,9	10,4	12,9	15,4	19,3	24,3
D2	20	24	28	32	42	50
D3	M6	M8	M10x1,25	M12x1,25	M16x1,5	M20x1,5
D4	10	12,5	15	17,5	22	27,5
D5	13	16	19	22	27	34
DK	12,7	15,87	19,05	22,22	28,57	34,92
$\varnothing D$	6	8	10	12	16	20
H1	30	36	43	50	64	77
L3	12	16	20	22	28	33
L4	40	48	57	66	85	102
L5	5	5	6,5	6,5	8	10
L7	11	13	15	17	23	27
W	11	14	17	19	22	30

SNODO SFERICO FILETTO ESTERNO

ROD EYE (EXTERNAL THREAD)

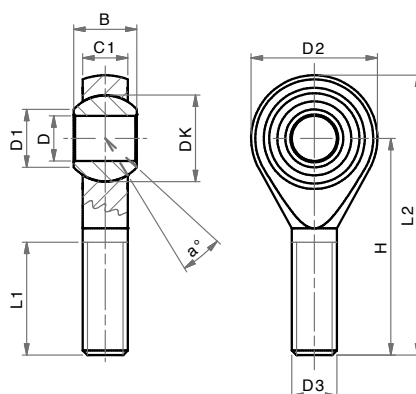

MATERIALE:
CORPO IN ACCIAIO ZINCATO
SNODO IN ACCIAIO,
BRONZO E PTFE
MATERIAL:
BODY IN ZINC COATED STEEL
EYE IN STEEL, BRONZE
AND PTFE

DIMENSIONI - DIMENSIONS

COD.	SSFE06x1	SSFE08x1,25	SSFE10x1,5	SSFE12x1,75	SSFE16x2
α°	13	14	13	13	15
B	9	12	14	16	21
C1	6,75	9	10,5	12	15
D1	8,9	10,4	12,9	15,4	19,3
D2	20	24	28	32	42
D3	M6	M8	M10	M12	M16
DK	12,7	15,87	19,05	22,22	28,57
$\varnothing D$	6	8	10	12	16
H	36	42	48	54	66
L1	21	25	28	32	37
L2	46	54	62	70	87

FORCELLA CON CLIPS

CLEVIS WITH LOCKABLE PIN

SERIE
P

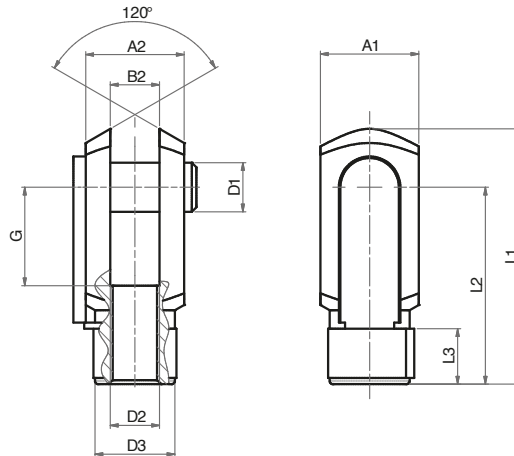

LA FORNITURA COMPRENDE:
n° 1 FORCELLA
n° 1 CLIPS
THE SUPPLY INCLUDES:
n° 1 FORK
n° 1 LOCKABLE PIN

MATERIALE:
ACCIAIO ZINCATO
MATERIAL:
ZINC COATED STEEL

DIMENSIONI - DIMENSIONS

COD.	FC06x1	FC08x1,25	FC10x1,25	FC12x1,25	FC16x1,5	FC20x1,5
A1	12	16	20	24	32	40
A2	12	16	20	24	32	40
B2	6	8	10	12	16	20
ø D1	6	8	10	12	16	20
D2	M6x1	M8x1,25	M10x1,25	M12x1,25	M16x1,5	M20x1,5
ø D3	10	14	18	20	26	34
G	12	16	20	24	32	40
L1	31	42	52	62	83	105
L2	24	32	40	48	64	80
L3	9	12	15	18	24	30

FORCELLA CON PERNO

CLEVIS WITH PIN

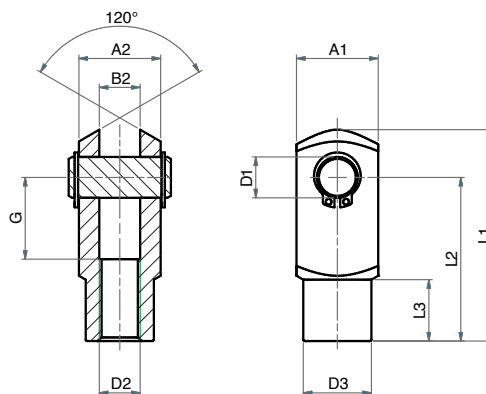

LA FORNITURA COMPRENDE:
n° 1 FORCELLA
n° 1 PERNO
n° 2 SEGER
THE SUPPLY INCLUDES:
n° 1 FORK
n° 1 PIN
n° 2 RETAINING RING

MATERIALE:
ACCIAIO ZINCATO
MATERIAL:
ZINC COATED STEEL

DIMENSIONI - DIMENSIONS

COD.	FP06x1	FP08x1,25	FP10x1,25	FP12x1,25	FP16x1,5	FP20x1,5
A1	12	16	20	24	32	40
A2	12	16	20	24	32	40
B2	6	8	10	12	16	20
ø D1	6	8	10	12	16	20
D2	M6x1	M8x1,25	M10x1,25	M12x1,25	M16x1,5	M20x1,5
ø D3	10	14	18	20	26	34
G	12	16	20	24	32	40
L1	31	42	52	62	83	105
L2	24	32	40	48	64	80
L3	9	12	15	18	24	30

SENSORI MAGNETICI

MAGNETIC SENSORS

CARATTERISTICHE - CHARACTERISTICS				
CODICE - CODE	36.SEN06 36.SEN06.L6	36.SEN07	36.SEN08	36.SEN09 36.SEN09.L6 36.SEN09.L10
TIPO - TYPE	REED	REED	ELETTRONICO ELECTRONIC	ELETTRONICO ELECTRONIC
Modello elettrico - Electrical design	AC/DC PNP/NPN	AC/DC PNP/NPN	DC PNP	DC PNP
Funzione dell'uscita - Output	NO	NO	NO	NO
Tensione di esercizio - Operating voltage	[V] 5...120 AC/DC	5...60 DC / 5...50 AC	10...30 DC	10...30 DC
Capacità di corrente - Current rating	[mA] 100*	100*	100	100
Sensibilità di reazione - Magnetic sensitivity	[mT] 2,1	2,1	2,8	2,8
Velocità di passaggio - Travel speed	[m/s] > 10	> 10	> 10	> 10
Protezione da cortocircuito - Short-circuit proof	no	no	si - yes	si - yes
Protetto da inversione di polarità Reverse polarity protection	si - yes	si - yes	si - yes	si - yes
Resistente a sovraccarico - Overload protection	no	no	si - yes	si - yes
Caduta di tensione - Voltage drop	[V] < 5	< 5	< 2,5	< 2,5
Isteresi - Hysteresis	1	1	< 1,5	< 1,5
Riproducibilità - Repeatability	[mm] ± 0,2	± 0,2	< 0,2	< 0,2
Corrente assorbita - Current consumption	[mA] -	-	< 10	< 10
Tempo di commutazione - Make time	[ms] ≤ 0,6	≤ 0,6	-	-
Tempo di riapertura - Fall time	[ms] ≤ 0,1	≤ 0,1	-	-
Potenza max - Switching power max	[W] 10	10	-	-
Cicli di commutazione con connessione a PLC Switching cycles when connected to PLC	[mln] ≤ 40	≤ 40	-	-
Frequenza di commutazione - Switching frequency	[Hz] 1.000	1.000	> 10.000	> 10.000
Temperatura ambiente - Ambient temperature	[°C] -25...70	-25...70	-25...80	-25...80
Grado/Classe di protezione - Protection	IP67, II	IP67, II	IP67, III	IP67, III
Materiale involucro - Housing material	PA (poliammide - polyamide)			
Materiale eccentrico di fissaggio - Fastening clamp	inox - stainless steel			
Indicazione della funzione Stato di commutazione Function display Switching status	LED	giallo - yellow		
Collegamento - Connection	cavo PUR - PUR cable 2x0,14 mm ² 2 m (.L6 = 6 m)	cavo PUR - PUR cable connettore M8- M8 connector 0,3 m	cavo PUR - PUR cable connettore M8- M8 connector 0,3 m	cavo PUR - PUR cable 3x0,14 mm ² 2 m (.L6 = 6 m .L10 = 10 m)
Peso - Weight	[g] 31,3 69	12	12,1	27,4 73,5 122,4

Accessori inclusi: Segnaposto in gomma, fascetta fermacavo - Accessories included: Rubber placeholder, cable clip

*: necessario circuito di protezione esterno per carico induttivo (valvola, relè, ecc...). - External protective circuit for inductive load (valve, contactor, etc...) necessary.

REED: nessuna funzione LED in caso di inversione di polarità nel funzionamento DC. - No LED function in case of polarity reversal in DC operation.

SERIE

P

CONTATTO REED (2 FILI)

36.SEN06

36.SEN06.L6

REED CONTACT (2 WIRES)

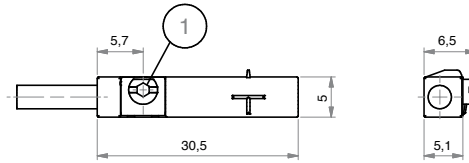

1= ECCENTRICO DI FISSAGGIO - FASTENING CLAMP

CABLAGGIO - WIRING

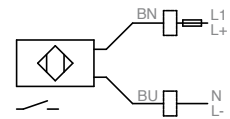

BN= MARRONE - BROWN
BU= BLU - BLUE

SERIE
P

CONTATTO REED (CONNETTORE M8)

36.SEN07

REED CONTACT (M8 CONNECTOR)

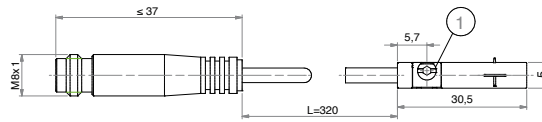

1= ECCENTRICO DI FISSAGGIO - FASTENING CLAMP

CABLAGGIO - WIRING

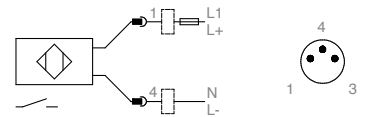

BN= MARRONE - BROWN
BU= BLU - BLUE

CONTATTO PNP (CONNETTORE M8)

36.SEN08

PNP CONTACT (M8 CONNECTOR)

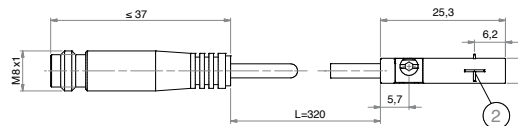

1= ECCENTRICO DI FISSAGGIO FASTENING CLAMP
2= SUPERFICIE ATTIVA SENSING FACE

CABLAGGIO - WIRING

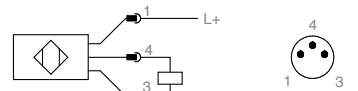

BN= MARRONE - BROWN
BU= BLU - BLUE

CONTATTO PNP (3 FILI)

36.SEN09

36.SEN09.L6

36.SEN09.L10

PNP CONTACT (3 WIRES)

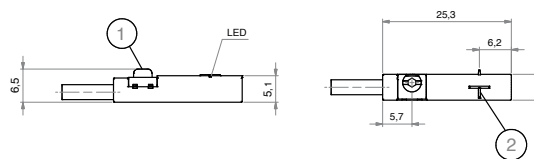

1= ECCENTRICO DI FISSAGGIO - FASTENING CLAMP
2= SUPERFICIE ATTIVA - SENSING FACE

CABLAGGIO - WIRING

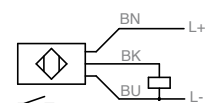

BK= NERO - BLACK
BN= MARRONE - BROWN
BU= BLU - BLUE

CAVO PROLUNGA (CONNETTORE M8)

36.CAV

EXTENSION CABLE (M8 CONNECTOR)

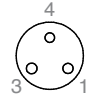
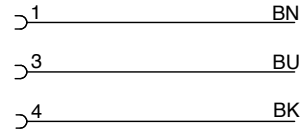
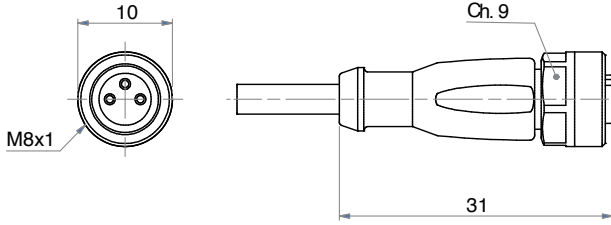

SERIE

P



SENSORI MAGNETICI ATEX

ATEX MAGNETIC SENSORS

SERIE
P

CARATTERISTICHE - CHARACTERISTICS		36.SEN32A.L6	36.SEN33A
TIPO - TYPE		ELETTRONICO - ELECTRONIC	ELETTRONICO - ELECTRONIC
Modello elettrico - Electrical design		DC PNP	DC PNP
Funzione dell'uscita - Output		NO	NO
Tensione di esercizio - Operating voltage	[V]	10...30 DC	10...30 DC
Capacità di corrente - Current rating	[mA]	100	100
Sensibilità di reazione - Magnetic sensitivity	[mT]	2	2,8
Velocità di passaggio - Travel speed	[m/s]	> 10	> 10
Protezione da cortocircuito - Short-circuit proof		si - yes	si - yes
Protetto da inversione di polarità - Reverse polarity protection		si - yes	si - yes
Resistente a sovraccarico - Overload protection		si - yes	si - yes
Caduta di tensione - Voltage drop	[V]	< 2,5	< 2,5
Isteresi - Hysteresis		1	< 1,5
Riproducibilità - Repeatability	[mm]	< 0,2	< 0,2
Corrente assorbita - Current consumption	[mA]	< 10	< 10
Ritardo alla disponibilità - Power-on delay time	[ms]	< 30	< 30
Frequenza di commutazione - Switching frequency	[Hz]	6.000	10.000
Temperatura ambiente - Ambient temperature	[°C]	-20...60	-25...60
Grado/Classe di protezione - Protection		IP 65/IP 67	IP 65/IP 67
Contrassegno - Marking of the unit		II 3D Ex tc IIIC T125°C Dc X II 3G Ex nA IIC T4 Gc X	II 3D Ex tc IIIC T125°C Dc X
Materiale involucro - Housing material		PA (poliammide-polyamide)	PA (poliammide-polyamide)
Materiale eccentrico di fissaggio - Fastening clamp		inox - stainless steel	inox - stainless steel
Indicazione della funzione Stato di commutazione Function display Switching status	LED	giallo - yellow	giallo - yellow
Collegamento - Connection		cavo PVC - PVC cable 3x0,14 mm ²	cavo PVC - PVC cable connettore M12 - M12 connector
Lunghezza cavo - Cable length		6 m	0,3 m
Peso - Weight		[g] 103,3	52,4

Accessori inclusi - Accessories included: Segnaposto in gomma, fascetta fermacavo - Rubber placeholder, cable clip



36.SEN32A.L6

CONTATTO PNP (3 FILI)

PNP CONTACT (3 WIRES)



1= ECCENTRICO DI FISSAGGIO - FASTENING CLAMP
2= SUPERFICIE ATTIVA - SENSING FACE

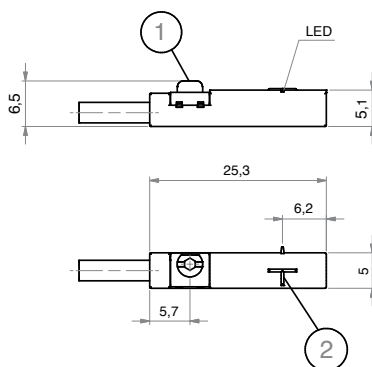

CABLAGGIO - WIRING

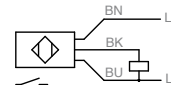

BK= NERO - BLACK
BN= MARRONE - BROWN
BU= BLU - BLUE

SERIE

P



36.SEN33A

CONTATTO PNP (CONNETTORE M12)

PNP CONTACT (M12 CONNECTOR)



1= ECCENTRICO DI FISSAGGIO - FASTENING CLAMP
2= SUPERFICIE ATTIVA - SENSING FACE

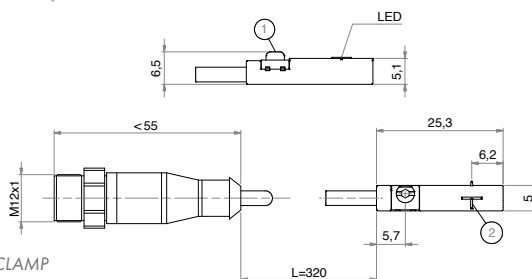

CABLAGGIO - WIRING

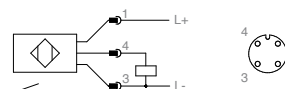

BK= NERO - BLACK
BN= MARRONE - BROWN
BU= BLU - BLUE



36.CAVA

CAVO PROLUNGA (CONNETTORE M12)

EXTENSION CABLE (M12 CONNECTOR)

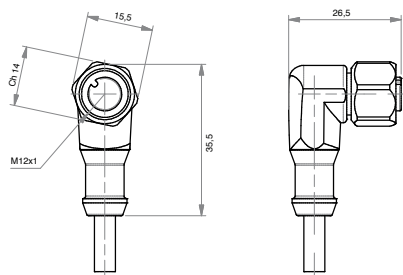

CABLAGGIO - WIRING

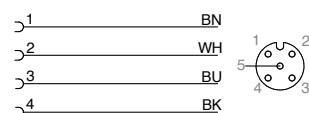

BK= NERO - BLACK
BN= MARRONE - BROWN

BU= BLU - BLUE
WH= BIANCO - WHITE

DIMENSIONI - DIMENSIONS	36.CAV5A.M12	36.CAV10A.M12
Modello elettrico - Electrical design	AC/DC	AC/DC
Tensione di esercizio - Operating voltage	[V] 60 AC / 60 DC	60 AC / 60 DC
Capacità di corrente - Current rating	[A] 2	2
Modello - Design	ad angolo - angled	ad angolo - angled
Temperatura ambiente - Ambient temperature	[°C] -20...60	-20...60
Grado/Classe di protezione - Protection	IP67/IP68 - IP69K fuori dalla zona esplosiva - outside hazardous areas	
Contrassegno - Marking of the unit	Ex II 3G Ex nA IIC Gc - Ex II 2D Ex tb IIIC Db IP65/IP67	
Materiale corpo - Body material: Involucro - Housing	TPU arancione - orange TPU	TPU arancione - orange TPU
Guarnizione - Sealing	viton	viton
Materiale dado - Nut material	inox - stainless steel (1.4404 / 316L)	inox - stainless steel (1.4404 / 316L)
Coppia di serraggio per nodo nocciolo Tightening torque for knurled nut	[Nm] 0,2...1,5	0,2...1,5
Collegamento - Connection	cavo PUR - PUR cable / 5 m; 4 x 0,34 mm ² (42 x Ø 0,1 mm); Ø 4,9 mm; senza alogeno - alogen free	cavo PUR - PUR cable / 10 m; 4 x 0,34 mm ² (42 x Ø 0,1 mm); Ø 4,9 mm; senza alogeno - alogen free
Colore della guaina - Sheath colour	nero - black	nero - black

AIR

THE BEST WAY TO



ARTEC SRL Via B. Zallone, 24

44042 CENTO (FE) - ITALY

☎ +39 051 683 62 20

☎ +39 051 683 08 82

✉ info@artec-pneumatic.com

🌐 www.artec-pneumatic.com



AZIENDA CON SISTEMA
DI GESTIONE QUALITÀ
CERTIFICATO ISO 9001:2015

PARTNER IN THE U.S.A & CANADA



W.C. Branham, Inc.

398 Troy Street

River Falls, WI 54022

☎ 800-428-1974 (Toll-free US & Canada)

715-426-2000 (Main)

☎ 715-426-1400

✉ AskWCB@wcbranham.com

🌐 www.wcbranham.com