

SERIE

V

CILINDRI TONDI IN ACCIAIO INOX
STAINLESS STEEL ROUND CYLINDERS

ARTEC[®]
PNEUMATIC COMPONENTS

 **WC
BRANHAM**[®]
SOLUTIONS IN MOTION

CARATTERISTICHE TECNICHE - TECHNICAL CHARACTERISTICS

Pressione di esercizio <i>Working pressure</i>	1 ÷ 10 bar
Temperatura di esercizio <i>Working temperature</i>	0 ÷ +80°C (-20°C con aria secca - <i>with dry air</i>) 0 ÷ +150°C (con guarnizioni per alte temperature - <i>with high temperature seals</i>)
Versioni - Versions	doppio effetto, stelo passante - <i>double acting, double rod</i>
Alesaggi - Bores	∅ 32 - 40 - 50 - 63
Corse - Strokes	vedere tabelle corse standard - <i>see standard stroke tables</i>
Fluido - Fluid	aria compressa filtrata, non lubrificata - <i>compressed filtered, non lubricated air</i>

CARATTERISTICHE COSTRUTTIVE - CONSTRUCTIVE CHARACTERISTICS

①	Dado - Nut	acciaio inox AISI 304 - <i>AISI 304 stainless steel</i>
②	Stelo - Rod	acciaio inox AISI 316 - <i>AISI 316 stainless steel</i>
③	Guarnizione stelo - Rod seal	poliuretano - <i>polyurethane</i>
④	Ghiera - Mounting Nut	acciaio inox AISI 304 - <i>AISI 304 stainless steel</i>
⑥ ⑰	Testate - Covers	acciaio inox AISI 316 - <i>AISI 316 stainless steel</i>
⑤	Boccola - Bush	acciaio inox AISI 316/PTFE - <i>AISI 316 stainless steel/PTFE</i>
⑦	Ammortizzo - Cushion	acciaio inox AISI 316 - <i>AISI 316 stainless steel</i>
⑧	Tubo - Tube	acciaio inox AISI 316 - <i>AISI 316 stainless steel</i>
⑨	Paracolpo - Bumper	NBR
⑩	Pistone - Piston	alluminio pressofuso - <i>die cast aluminium</i>
⑪	Pattino di guida - Guide ring	PBT+PTFE
⑫	Magnete - Magnet	plastoferrite - <i>rubber magnet</i>
⑬ ⑰	Guarnizioni - Seals	poliuretano - <i>polyurethane</i>
⑭	Guarnizioni - Seals	NBR
⑮	Anelli - Rings	PTFE
	Snodo sferico (versione T4) - Ball joint (version T4)	acciaio inox AISI 304/PTFE - <i>AISI 304 stainless steel/PTFE</i>

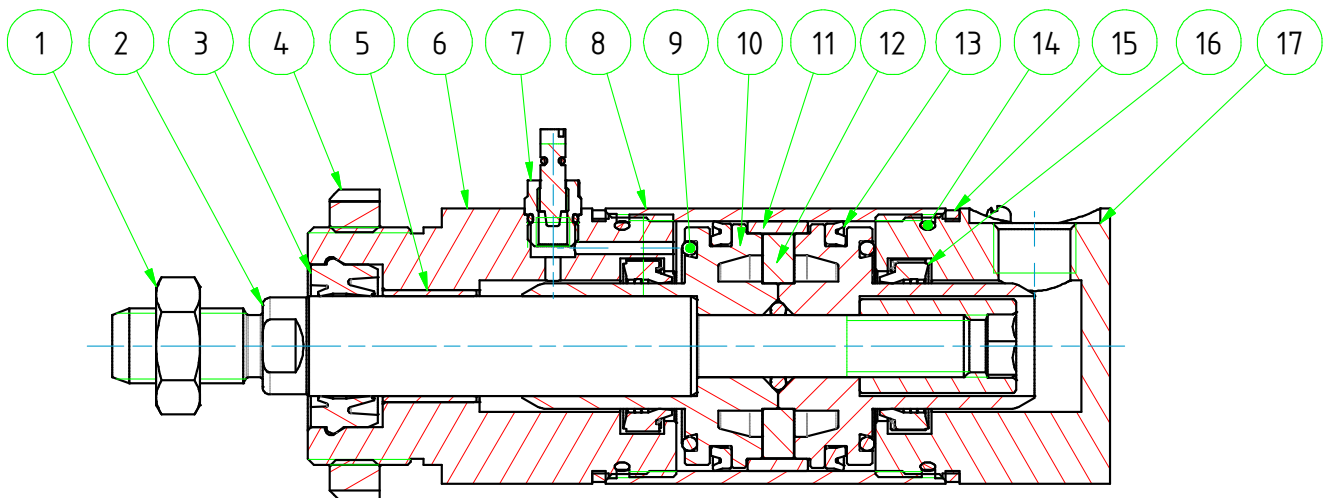

CHIAVE DI CODIFICA

KEY CODE

V	D	M	032	.050	.GS	.M		
			ALESAGGIO - BORE (Ø) 032-040-050-063	CORSA - STROKE (mm) vedere tabelle corse std see std stroke tables				OPZIONE - OPTION EX ATEX  II 2GD cT4
			VERSIONE - VERSION P stelo passante double rod				OPZIONE - OPTION	
			VERSIONE - VERSION M magnetico magnetico				T1 con testa anteriore filettata with threaded front head	
			non magnetico non-magnetic				T2 con cerniera femmina with female hinge	
			VERSIONE - VERSION D doppio effetto double acting				T3 con cerniera maschio with male hinge	
			SERIE - SERIES V tubo tondo INOX 316 avvitato screwed AISI 316 SS round tube				T4 con cerniera maschio snodata with male hinge with ball joint	
							STELO - ROD M maschio - male	
							GUARNIZIONI - SEALS	
							GS guarnizioni standard standard seals	
							VR guarnizione stelo per alte temperature high temperature rod seal	
							VA tutte le guarnizioni per alte temperature all seals for high temperature	

ESECUZIONI A RICHIESTA - ON REQUEST

Filetti speciali (dado non fornito) - Special thread (without rod nut)

Stelo prolungato (WH) - Extended rod (WH)

Corse fuori standard - Special strokes

ATEX  II 2GD c T4

FORZE TEORICHE DI TRAZIONE (P=6bar)

THEORETICAL FORCES OF TRACTION (P=6bar)

		Ø	32	40	50	63
VDM	SPINTA THRUST	[N]	483	753	1178	1870
	TRAZIONE TRACTION	[N]	415	633	990	1682
VDMP	SPINTA THRUST	[N]	415	633	990	1682
	TRAZIONE TRACTION	[N]	415	633	990	1682

SERIE

V

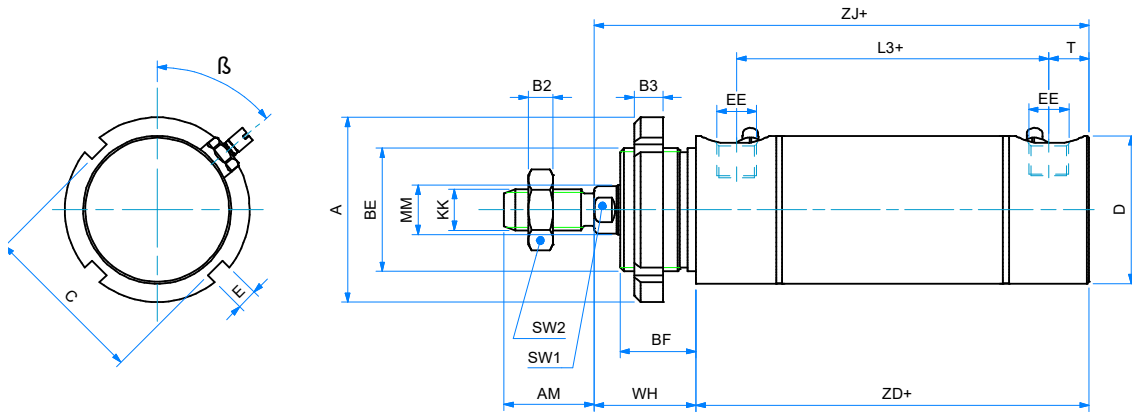
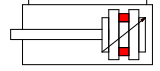
DOPPIO EFFETTO MAGNETICO AMMORTIZZATO CON TESTA ANTERIORE FILETTATA
DOUBLE ACTING MAGNETIC CUSHIONED WITH THREADED FRONT HEAD

Note: dado stelo e ghiera compresi nella fornitura
 Note: rod nut and slotted nut included in the supply

DIMENSIONI - DIMENSIONS

	32	40	50	63
∅ A	45	50	58	58
AM	22	24	32	32
β	50°	50°	50°	50°
B2	6	7	8	8
B3	7	8	9	9
BE	M30x1,5	M38x1,5	M45x1,5	M45x1,5
BF	18,5	21,5	27	27
C	40	46	52	52
∅ D	36	44	54	67
E	5	5	6	6
EE	G 1/8"	G 1/4"	G 1/4"	G 3/8"
KK	M10x1,25	M12x1,25	M16x1,5	M16x1,5
L3	77	83	82	96
∅ MM	12	16	20	20
SW1	10	13	17	17
SW2	17	19	24	24
T	9,5	12	12,5	13,5
WH	25	29	36	36
ZD+	95	106	107	122
ZJ+	120	135	143	158

+ = lunghezza corsa - stroke length

∅ CORSE STANDARD - STANDARD STROKES

032	25 - 50 - 80 - 100 - 125 - 150 - 160 - 200 - 250 - 300 - 320 - 350 - 400 - 450 - 500
040	25 - 50 - 80 - 100 - 125 - 150 - 160 - 200 - 250 - 300 - 320 - 350 - 400 - 450 - 500
050	25 - 50 - 80 - 100 - 125 - 150 - 160 - 200 - 250 - 300 - 320 - 350 - 400 - 450 - 500
063	25 - 50 - 80 - 100 - 125 - 150 - 160 - 200 - 250 - 300 - 320 - 350 - 400 - 450 - 500

D. E. M. STELO PASSANTE AMMORTIZZATO CON TESTE FILETTATE

D. A. M. DOUBLE ROD CUSHIONED WITH THREADED HEADS

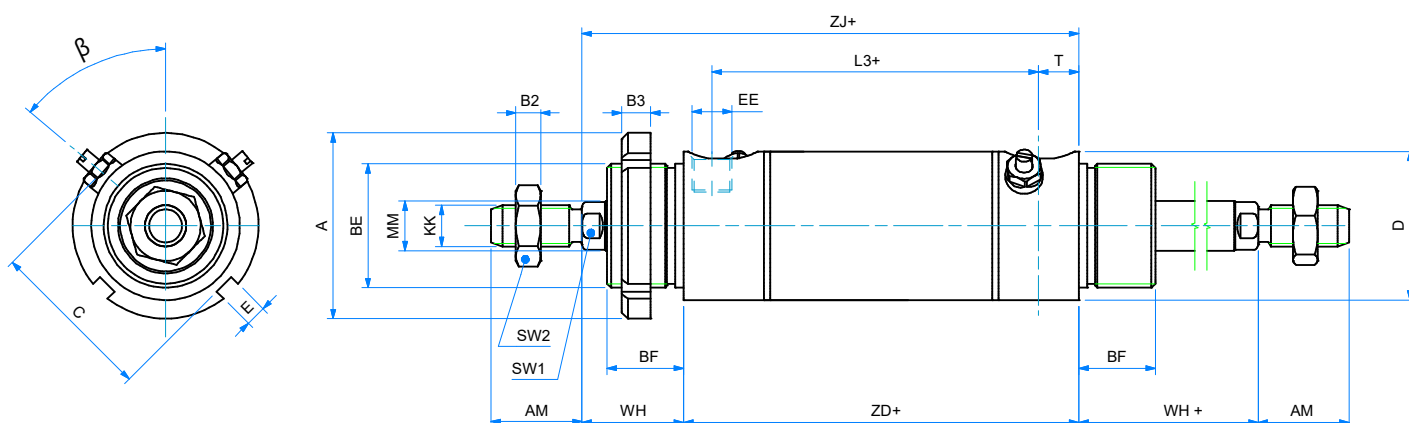
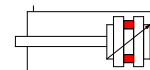

Note: 2 dadi stelo e 1 ghiera compresi nella fornitura
Note: 2 rod nuts and 1 slotted nut included in the supply

DIMENSIONI - DIMENSIONS					
ø	32	40	50	63	
ø A	45	50	58	58	
AM	22	24	32	32	
β	50°	50°	50°	50°	
B2	6	7	8	8	
B3	7	8	9	9	
BE	M30x1,5	M38x1,5	M45x1,5	M45x1,5	
BF	18,5	21,5	27	27	
C	40	46	52	52	
ø D	36	44	54	67	
E	5	5	6	6	
EE	G 1/8"	G 1/4"	G 1/4"	G 3/8"	
KK	M10x1,25	M12x1,25	M16x1,5	M16x1,5	
L3	77	83	82	96	
ø MM	12	16	20	20	
SW1	10	13	17	17	
SW2	17	19	24	24	
T	9,5	12	12,5	13,5	
WH	25	29	36	36	
WH+	25	29	36	36	
ZD+	95	106	107	122	
ZJ+	120	135	143	158	

+ = lunghezza corsa - stroke length

ø	CORSE STANDARD - STANDARD STROKES														
032	25	50	80	100	125	150	160	200	250	300	320	350	400	450	500
040	25	50	80	100	125	150	160	200	250	300	320	350	400	450	500
050	25	50	80	100	125	150	160	200	250	300	320	350	400	450	500
063	25	50	80	100	125	150	160	200	250	300	320	350	400	450	500

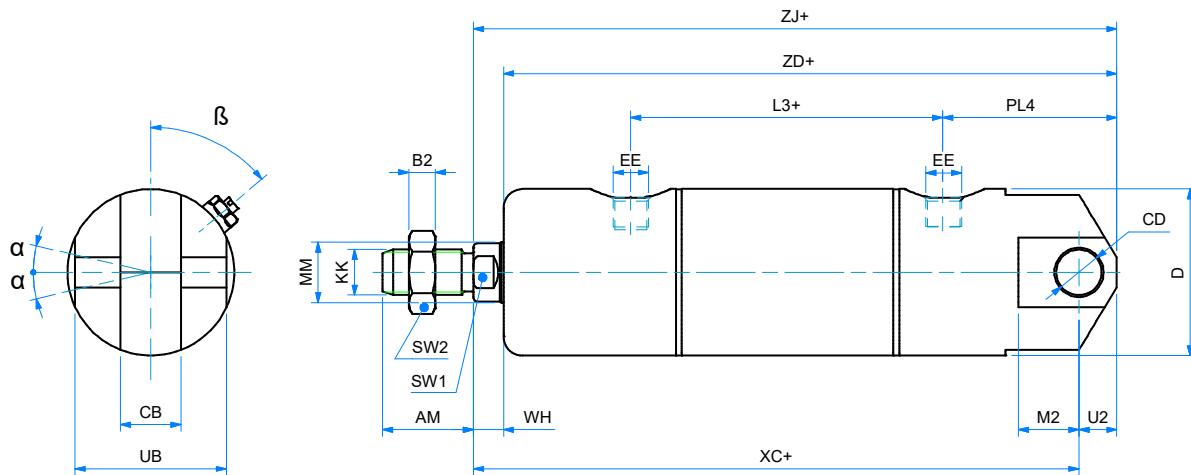
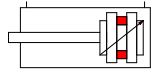
DOPPIO EFFETTO MAGNETICO AMMORTIZZATO CON CERNIERA FEMMINA
DOUBLE ACTING MAGNETIC CUSHIONED WITH FEMALE HINGE

Note: dado stelo compreso nella fornitura
 Note: rod nut included in the supply

DIMENSIONI - DIMENSIONS

\varnothing	32	40	50	63
AM	22	24	32	32
β	50°	50°	50°	50°
B2	6	7	8	8
CB	14	16	21	21
\varnothing CD	10	12	12	16
\varnothing D	36	44	54	67
EE	G 1/8"	G 1/4"	G 1/4"	G 3/8"
EW	26	28	32	40
KK	M10x1,25	M12x1,25	M16x1,5	M16x1,5
L3	77	83	82	96
M2	13	16	16	21
\varnothing MM	12	16	20	20
PL3	36,5	45,5	53	58,5
SW1	10	13	17	17
SW2	17	19	24	24
U2	10	10	12	12
UB	34	40	45	51
WH	11	8	8	8
XC+	142	160	170	190
ZD+	141	162	174	194
ZJ+	152	170	182	202

+ = lunghezza corsa - stroke length

 \varnothing CORSE STANDARD - STANDARD STROKES

032	25 - 50 - 80 - 100 - 125 - 150 - 160 - 200 - 250 - 300 - 320 - 350 - 400 - 450 - 500
040	25 - 50 - 80 - 100 - 125 - 150 - 160 - 200 - 250 - 300 - 320 - 350 - 400 - 450 - 500
050	25 - 50 - 80 - 100 - 125 - 150 - 160 - 200 - 250 - 300 - 320 - 350 - 400 - 450 - 500
063	25 - 50 - 80 - 100 - 125 - 150 - 160 - 200 - 250 - 300 - 320 - 350 - 400 - 450 - 500

DOPPIO EFFETTO MAGNETICO AMMORTIZZATO CON CERNIERA MASCHIO

DOUBLE ACTING MAGNETIC CUSHIONED WITH MALE HINGE

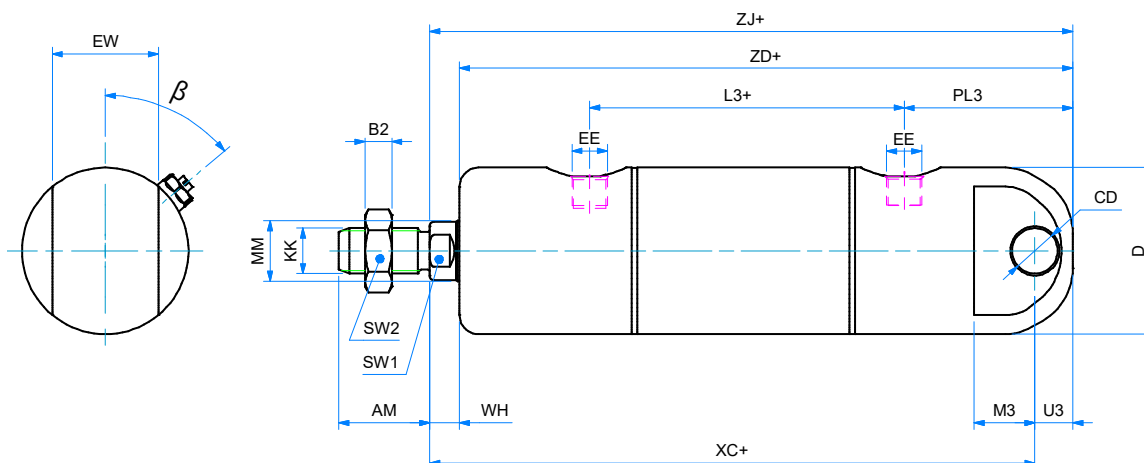
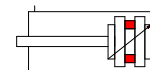

Note: dado stelo compreso nella fornitura
Note: rod nut included in the supply

DIMENSIONI - DIMENSIONS

\emptyset	32	40	50	63
AM	22	24	32	32
β	50°	50°	50°	50°
B2	6	7	8	8
\emptyset CD	10	12	12	16
\emptyset D	36	44	54	67
EE	G 1/8"	G 1/4"	G 1/4"	G 3/8"
EW	26	28	32	40
KK	M10x1,25	M12x1,25	M16x1,5	M16x1,5
L3	77	83	82	96
M3	13	16	16	21
\emptyset MM	12	16	20	20
PL3	36,5	45,5	53	58,5
SW1	10	13	17	17
SW2	17	19	24	24
U3	10	10	12	12
WH	11	8	8	8
XC+	142	160	170	190
ZD+	141	162	174	194
ZJ+	152	170	182	202

+ = lunghezza corsa - stroke length

\emptyset CORSE STANDARD - STANDARD STROKES

032	25 - 50 - 80 - 100 - 125 - 150 - 160 - 200 - 250 - 300 - 320 - 350 - 400 - 450 - 500
040	25 - 50 - 80 - 100 - 125 - 150 - 160 - 200 - 250 - 300 - 320 - 350 - 400 - 450 - 500
050	25 - 50 - 80 - 100 - 125 - 150 - 160 - 200 - 250 - 300 - 320 - 350 - 400 - 450 - 500
063	25 - 50 - 80 - 100 - 125 - 150 - 160 - 200 - 250 - 300 - 320 - 350 - 400 - 450 - 500

DOPPIO EFFETTO MAGNETICO AMMORTIZZATO CON CERNIERA MASCHIO SNODATA

DOUBLE ACTING MAGNETIC CUSHIONED WITH MALE HINGE WITH BALL JOINT

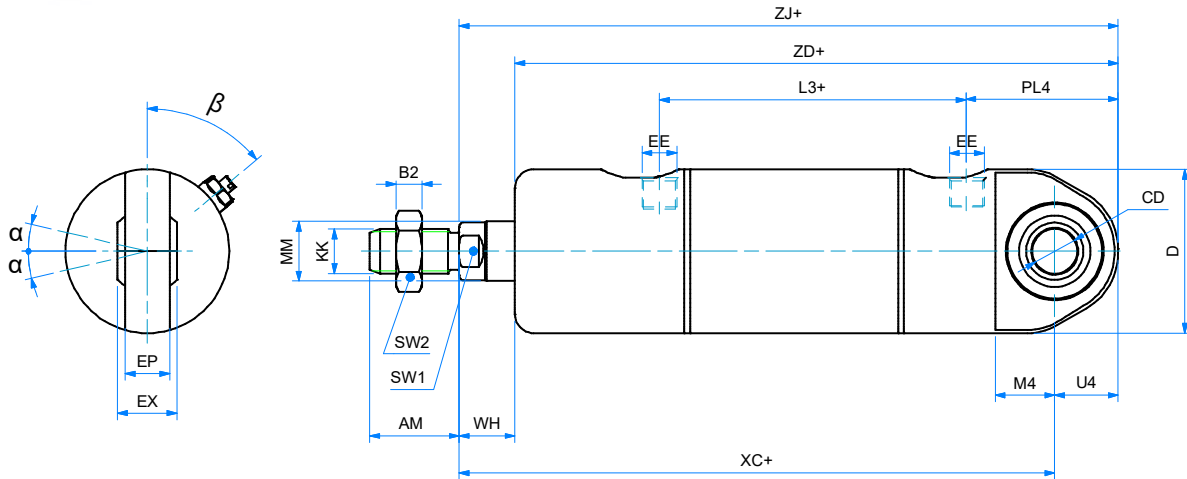
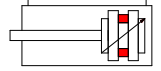

Note: dado stelo e ghiera compresi nella fornitura
Note: rod nut and slotted nut included in the supply

DIMENSIONI - DIMENSIONS

	32	40	50	63
α	13°	13°	15°	15°
AM	22	24	32	32
β	50°	50°	50°	50°
B2	6	7	8	8
\varnothing CD	10	12	16	16
\varnothing D	36	44	54	67
EE	G 1/8"	G 1/4"	G 1/4"	G 3/8"
EP	10,5	12	15	15
EX	14	16	21	21
KK	M10x1,25	M12x1,25	M16x1,5	M16x1,5
L3	77	83	82	96
M4	13	16	20	21
\varnothing MM	12	16	20	20
PL4	36,5	45,5	53	58
SW1	10	13	17	17
SW2	17	19	24	24
U4	15	17	20	22
WH	16	15	15	17
XC+	142	160	170	190
ZD+	141	162	175	195
ZJ+	157	177	190	212

+ = lunghezza corsa - stroke length

\varnothing CORSE STANDARD - STANDARD STROKES

032	25 - 50 - 80 - 100 - 125 - 150 - 160 - 200 - 250 - 300 - 320 - 350 - 400 - 450 - 500
040	25 - 50 - 80 - 100 - 125 - 150 - 160 - 200 - 250 - 300 - 320 - 350 - 400 - 450 - 500
050	25 - 50 - 80 - 100 - 125 - 150 - 160 - 200 - 250 - 300 - 320 - 350 - 400 - 450 - 500
063	25 - 50 - 80 - 100 - 125 - 150 - 160 - 200 - 250 - 300 - 320 - 350 - 400 - 450 - 500

ACCESSORI DI FISSAGGIO CILINDRO TONDO INOX

STAINLESS STEEL ROUND CYLINDER MOUNTING PARTS

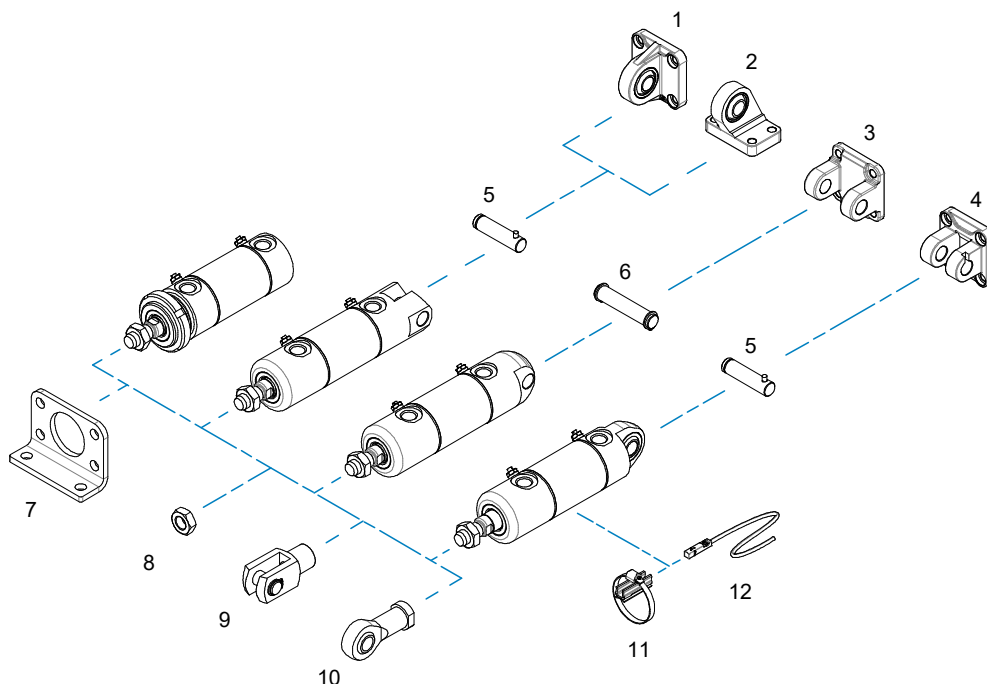

POS.	CODE	DESCRIZIONE - DESCRIPTION
1	CMSI---X6	cerniera maschio snodata iso inox AISI 316 - ss AISI 316 iso male hinge with ball joint
2	ASSI---X6	articolazione a squadra snodata inox AISI 316 - ss AISI 316 iso square hinge with ball joint
3	CFI---X6	cerniera femmina iso inox AISI 316 - ss AISI 316 iso female hinge
4	CFSI---X6	cerniera femmina stretta inox AISI 316 - ss AISI 316 narrow female hinge
5	PCFS---X6	perno per cerniera femmina stretta inox AISI 316 - ss AISI 316 pin for narrow female hinge
6	PCF---X6	perno per cerniera inox AISI 316 - ss AISI 316 pin for hinge
7	MPBI---X	piedino flangia inox AISI 304 - foot flange ss AISI 304
8	DA--x---X	dado stelo inox AISI 304- ss AISI 304 rod nut
9	FP--x---X6	forcella con perno inox AISI 316- ss AISI 316 clevis with pin
10	SSFI--x---X6	snodo sferico inox AISI 316 - ss AISI 316 rod eye
11	36.TIRX---	fascetta di fissaggio - fixing clamp
12	36.SEN---	sensore magnetico - magnetic sensor

PIEDINO FLANGIA

MPBI X

FOOT FLANGE

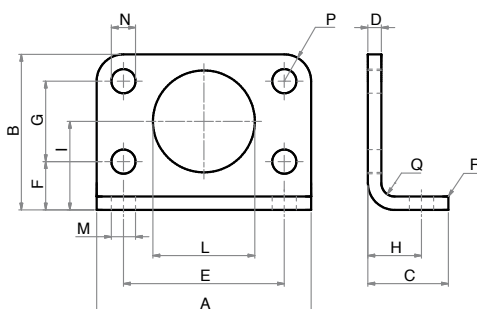

MATERIALE:
ACCIAIO INOX AISI 304
MATERIAL:
AISI 304 STAINLESS STEEL

DIMENSIONI - DIMENSIONS

COD.	MPBI032X	MPBI040X	MPBI050X	MPBI063X
ø mm	32	40	50	63
A	66	80	90	96
B	49	58	70	80
C	21	30	30	30
D	4	5	6	6
E	52	60	70	76
F	14	18	20	20
G	28	30	40	50
H	14	20	20	20
I	28	33	40	45
L	30	38	45	45
M	7	9	9	9
N	7	9	9	9
P	7	10	10	10
Q	4	5	6	6
R	2	2	2	2

SERIE

V

CERNIERA MASCHIO ISO INOX (MP4)

STAINLESS STEEL ISO MALE HINGE (MP4)

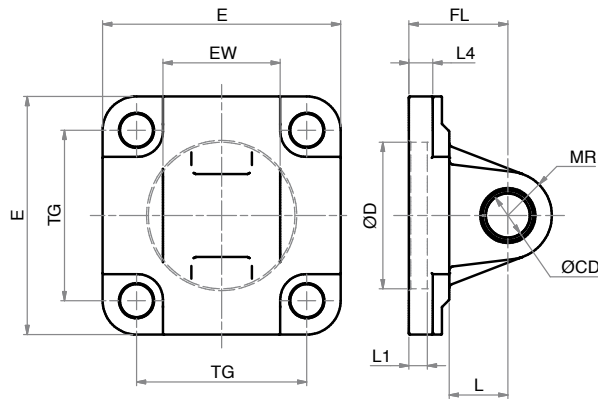

LA FORNITURA COMPRENDE:
n° 1 CERNIERA MASCHIO
n° 4 VITI
THE SUPPLY INCLUDES:
n° 1 MALE HINGE
n° 4 SCREWS

MATERIALE:
ACCIAIO INOX AISI 304
MATERIAL:
AISI 304 STAINLESS STEEL

DIMENSIONI - DIMENSIONS

COD.	CMI032X	CMI040X	CMI050X	CMI063X
Ø	32	40	50	63
E	45	52	65	75
EW	26	28	32	40
TG	32,5	38	46,5	56,5
FL	22	25	27	32
L1	5	5	5	5
L	13	16	16	21
L4	5,5	5,5	6,5	6,5
Ø D	30	35	40	45
Ø CD	10	12	12	16
MR	10	12	12	16

CERNIERA FEMMINA ISO INOX (MP2)

STAINLESS STEEL ISO FEMALE HINGE (MP2)

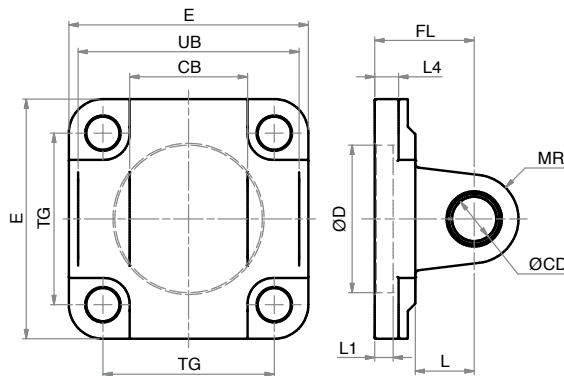

LA FORNITURA COMPRENDE:
n° 1 CERNIERA FEMMINA
n° 4 VITI
THE SUPPLY INCLUDES:
n° 1 FEMALE HINGE
n° 4 SCREWS

MATERIALE:
ACCIAIO INOX AISI 304
MATERIAL:
AISI 304 STAINLESS STEEL

DIMENSIONI - DIMENSIONS

COD.	CFI032X	CFI040X	CFI050X	CFI063X
Ø	32	40	50	63
CB	26	28	32	40
E	45	52	65	75
FL	22	25	27	32
L1	5	5	5	5
L4	5,5	5,5	6,5	6,5
L	13	16	16	21
MR	10	12	12	16
Ø CD	10	12	12	16
Ø D	30	35	40	45
TG	32,5	38	46,5	56,5
UB	45	52	60	70

CERNIERA FEMMINA STRETTA ISO INOX (AB6)

CFSI X6

STAINLESS STEEL ISO NARROW FEMALE HINGE (AB6)

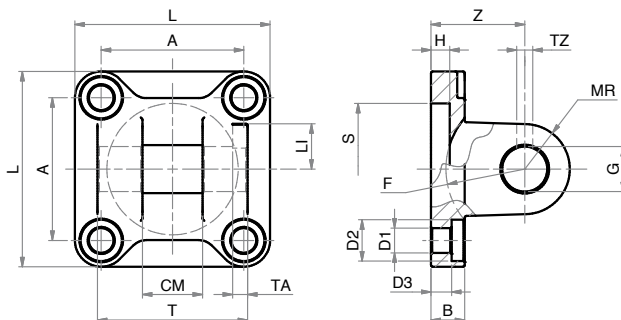
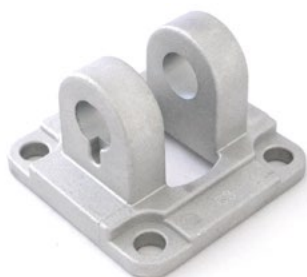

LA FORNITURA COMPRENDE:
n° 1 CERNIERA FEMMINA
n° 4 VITI
THE SUPPLY INCLUDES:
n° 1 FEMALE HINGE
n° 4 SCREWS

MATERIALE:
ACCIAIO INOX AISI 316
MATERIAL:
AISI 316 STAINLESS STEEL

DIMENSIONI - DIMENSIONS

COD.	CFSI032X6	CFSI040X6	CFSI050X6	CFSI063X6
ø	32	40	50	63
A	32,5	38	46,5	56,5
B	9	9	11	11
CM	14	16	21	21
D1	6,6	6,6	9	9
D2	11	11	15	15
D3	5,5	5,5	6,5	6,5
F min.	17	20	22	25
G	10	12	16	16
H	5	5	5	5
LI	11,5	12	14	14
L	45	52	65	75
MR	10	12	14	18
S	30	35	40	45
TA	3	4	4	4
TZ	3,3	4,3	4,3	4,3
T	34	40	45	51
Z	22	25	27	32

PERNO PER CERNIERA STRETTA INOX (AA6)

PCFS X6

STAINLESS STEEL PIN FOR NARROW HINGE (AA6)

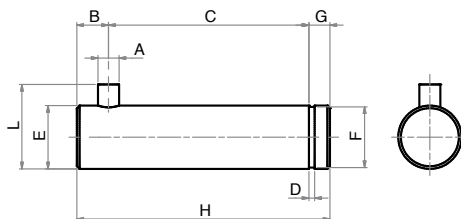

LA FORNITURA COMPRENDE:
n° 1 PERNO
n° 1 SEEGER
THE SUPPLY INCLUDES:
n° 1 PIN
n° 1 RETAINING RING

MATERIALE:
ACCIAIO INOX AISI 316
MATERIAL:
AISI 316 STAINLESS STEEL

DIMENSIONI - DIMENSIONS

COD.	PCFS032X6	PCFS040X6	PCFS050X6	PCFS063X6
ø	32	40	50	63
A	3	4	4	4
B	4,5	6	6	6
C	32,5	38	43	49
D	1,1	1,1	1,1	1,1
E	10	12	16	16
F	9,6	11,5	15,2	15,2
G	4	4	5	5
H	41	48	54	60
L	14	16	20	20

SERIE

V

SNODO SFERICO INOX (FILETTO INTERNO)

STAINLESS STEEL ROD EYE (INTERNAL THREAD)

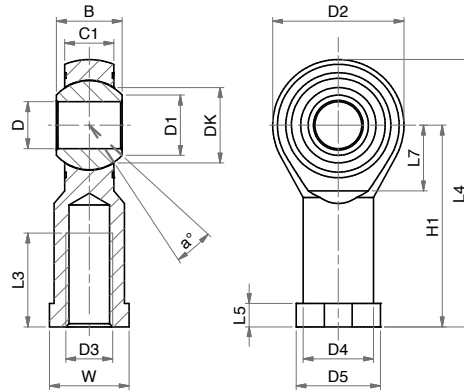

MATERIALE:
CORPO IN ACCIAIO
INOX AISI 304
SNODO IN ACCIAIO
INOX E PTFE
MATERIAL:
BODY IN
AISI 304 STAINLESS STEEL
EYE IN STAINLESS STEEL
AND PTFE

DIMENSIONI - DIMENSIONS

COD.	SSFI10x1,25X	SSFI12x1,25X	SSFI16x1,5X
α°	13	13	15
B	14	16	21
C1	10,5	12	15
D1	12,9	15,4	19,3
D2	28	32	42
D3	M10x1,25	M12x1,25	M16x1,5
D4	15	17,5	22
D5	19	22	27
DK	19,05	22,22	28,57
D	10	12	16
H1	43	50	64
L3	20	22	28
L4	57	66	85
L5	6,5	6,5	8
L7	15	17	23
W	17	19	22

FORCELLA CON PERNO INOX

STAINLESS STEEL CLEVIS WITH PIN

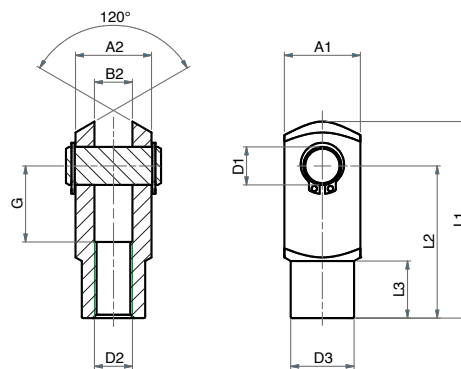

MATERIALE:
ACCIAIO INOX AISI 304
MATERIAL:
AISI 304 STAINLESS STEEL

LA FORNITURA COMPRENDE:
n° 1 PERNO
n° 2 SEEGER
THE SUPPLY INCLUDES:
n° 1 PIN
n° 2 RETAINING RING

DIMENSIONI - DIMENSIONS

COD.	FP10x1,25X	FP12x1,25X	FP16x1,5X
A1	20	24	32
A2	20	24	32
B2	10	12	16
G	20	24	32
L1	52	62	83
L2	40	48	64
L3	15	18	24
\varnothing D2	M10x1,25	M12x1,25	M16x1,5
\varnothing D3	18	20	26
\varnothing D1	10	12	16

SENSORI MAGNETICI PER ZONE ASETTICHE E UMIDE

MAGNETIC SENSORS FOR ASEPTICAL AND WET AREAS

CARATTERISTICHE - CHARACTERISTICS			
CODICE - CODE		36.SEN22	36.SEN23
TIPO - TYPE		ELETTRONICO - ELECTRONIC	ELETTRONICO - ELECTRONIC
Modello elettrico - Electrical design		DC PNP	DC PNP
Funzione dell'uscita - Output		N.O.	N.O.
Tensione di esercizio - Operating voltage	[V]	10...30 DC	10...30 DC
Capacità di corrente - Current rating	[mA]	100	100
Sensibilità di reazione - Magnetic sensitivity	[mT]	2,8	2,8
Velocità di passaggio - Travel speed	[m/s]	> 10	> 10
Protezione da cortocircuito - Short-circuit proof		si - yes	si - yes
Protetto da inversione di polarità - Reverse polarity protection		si - yes	si - yes
Resistente a sovraccarico - Overload protection		si - yes	si - yes
Caduta di tensione - Voltage drop	[V]	< 2,5	< 2,5
Isteresi - Hysteresis		1,5	1,5
Riproducibilità - Repeatability	[mm]	< 0,2	< 0,2
Corrente assorbita - Current consumption	[mA]	< 10	< 10
Ritardo alla disponibilità - Power-on delay time	[ms]	< 30	< 30
Frequenza di commutazione - Switching frequency	[Hz]	> 10.000	> 10.000
Temperatura ambiente - Ambient temperature	[°C]	-25...85	-25...85
Grado/Classe di protezione - Protection		IP 65/IP 67/IP 69K, III	IP 65/IP 67/IP 69K, III
Materiale involucro - Housing material		PA - (poliammide-polyamide)	PA - (poliammide-polyamide)
Materiale eccentrico di fissaggio - Fastening clamp		inox - stainless steel	inox - stainless steel
Indicazione della funzione Stato di commutazione Function display Switching status	LED	giallo - yellow	giallo - yellow
Collegamento - Connection		cavo PVC - PVC cable 3x0,14 mm ²	cavo PVC - PVC cable connettore M12 - M12 connector
Lunghezza cavo - Cable length		6 m	0,3 m
Peso - Weight	[g]	95,5	20,9

Accessori inclusi - Accessories included: Segnaposto in gomma, fascetta fermacavo - Rubber placeholder, cable clip

FASCETTA DI FISSAGGIO

36.TIRX

FIXING CLAMP

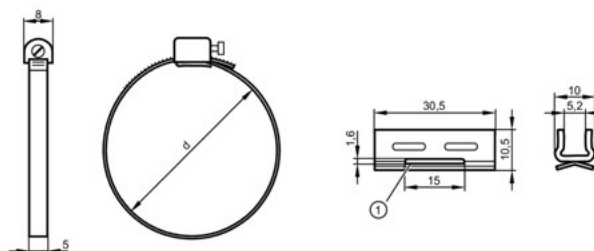

DIMENSIONI DIMENSIONS				
COD.	36.TIRX25.32	36.TIRX40	36.TIRX50	36.TIRX63
Ø	032	040	050	063
d [mm]	28÷39	38÷49	48÷59	58÷69
Materiale fascetta Fixing clamp material	acciaio inox AISI 303 - AISI 303 stainless steel			
Materiale adattatore Adapter material	acciaio inox AISI 304 - AISI 304 stainless steel			

SERIE
V

CONTATTO PNP (3 FILI)
PNP CONTACT (3 WIRES)

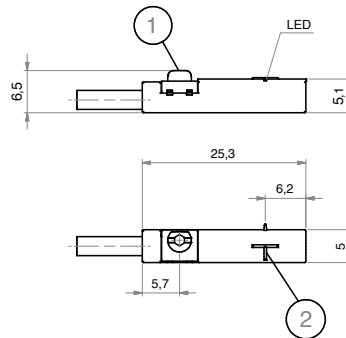
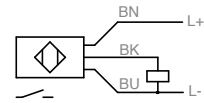

1= ECCENTRICO DI FISSAGGIO - FASTENING CLAMP
2= SUPERFICIE ATTIVA - SENSING FACE

CABLAGGIO - WIRING

BK= NERO - BLACK
BN= MARRONE - BROWN
BU= BLU - BLUE

CONTATTO PNP (CONNETTORE M12)
PNP CONTACT (M12 CONNECTOR)

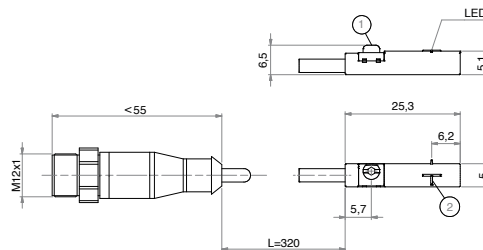
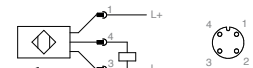
1= ECCENTRICO DI FISSAGGIO - FASTENING CLAMP
2= SUPERFICIE ATTIVA - SENSING FACE

CABLAGGIO - WIRING

BK= NERO - BLACK
BN= MARRONE - BROWN
BU= BLU - BLUE

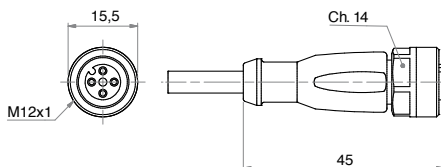
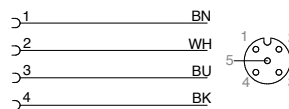
CAVO PROLUNGA (CONNETTORE M12)
EXTENSION CABLE (M12 CONNECTOR)

CABLAGGIO - WIRING

BK= NERO - BLACK
BN= MARRONE - BROWN
BU= BLU - BLUE
WH= BIANCO - WHITE

DIMENSIONI - DIMENSIONS

		36.CAVX2. M12	36.CAVX5. M12
Modello elettrico - Electrical design		AC/DC	AC/DC
Tensione di esercizio - Operating voltage	[V]	250 AC / 300 DC	250 AC / 300 DC
Capacità di corrente - Current rating	[A]	4	4
Modello - Design		diritto - straight	diritto - straight
Temperatura ambiente - Ambient temperature	[°C]	-25...90 (cRUus:max 50°C)	-25...90 (cRUus:max 50°C)
Grado/Classe di protezione - Protection		IP 67 / IP 68 / IP 69K, II	IP 67 / IP 68 / IP 69K, II
Materiale corpo - Body material: Involucro - Housing		TPU arancione - orange TPU	TPU arancione - orange TPU
Guarnizione - Sealing		viton	viton
Materiale dado - Nut material		ottone nichelato - nickel-plated brass	ottone nichelato - nickel-plated brass
Coppia di serraggio per nodo nocciolo - Tightening torque for knurled nut	[Nm]	0,6...1,5	0,6...1,5
Collegamento - Connection		cavo PUR - PUR cable / 2 m; 4 x 0,34 mm ² (42 x Ø 0,1 mm); Ø 4,9 mm; senza alogeno - alogen free	cavo PUR - PUR cable / 5 m; 4 x 0,34 mm ² (42 x Ø 0,1 mm); Ø 4,9 mm; senza alogeno - alogen free
Colore della guaina - Sheath colour		nero - black	nero - black

AIR

THE BEST WAY TO



ARTEC SRL Via B. Zallone, 24

44042 CENTO (FE) - ITALY

☎ +39 051 683 62 20

☎ +39 051 683 08 82

✉ info@artec-pneumatic.com

🌐 www.artec-pneumatic.com



AZIENDA CON SISTEMA
DI GESTIONE QUALITÀ
CERTIFICATO ISO 9001:2015

PARTNER IN THE U.S.A & CANADA



W.C. Branham, Inc.

398 Troy Street

River Falls, WI 54022

☎ 800-428-1974 (Toll-free US & Canada)

715-426-2000 (Main)

☎ 715-426-1400

✉ AskWCB@wcbranham.com

🌐 www.wcbranham.com