

SERIE

X

**CILINDRI COMPATTI
INOX ISO 21287**
ISO 21287 STAINLESS STEEL
COMPACT CYLINDERS

ARTEC[®]
PNEUMATIC COMPONENTS

 **WC
BRANHAM**[®]
SOLUTIONS IN MOTION

CARATTERISTICHE TECNICHE - TECHNICAL CHARACTERISTICS

Pressione di esercizio <i>Working pressure</i>	1 ÷ 10 bar (doppio effetto - <i>double acting</i>) 2 ÷ 10 bar (semplice effetto - <i>single acting</i>)
Temperatura di esercizio <i>Working temperature</i>	0 ÷ +80°C (-20°C con aria secca - <i>with dry air</i>) 0 ÷ +150°C (con guarnizioni per alte temperature - <i>with high temperature seals</i>)
Versioni - Versions	semplice effetto - doppio effetto - antirotazione - stelo passante <i>single acting - double acting - anti-rotation - double rod</i>
Alesaggi - Bores	Ø 20 - 25 - 32 - 40 - 50 - 63 - 80 - 100 - 125 - 160 - 200
Corse - Strokes	vedere tabelle corse standard - <i>see standard stroke tables</i>
Fluidi - Fluid	aria compressa filtrata, non lubrificata - <i>compressed filtered, non lubricated air</i>

CARATTERISTICHE COSTRUTTIVE - CONSTRUCTIVE CHARACTERISTICS

①	Stelo - Rod	Ø 020 ÷ 100 acciaio inox AISI 316 - <i>AISI 316 stainless steel</i> Ø 125 ÷ 200 acciaio inox AISI 316 - <i>AISI 316 stainless steel</i>
② ⑨	Guarnizioni - Seals	poliuretano - <i>polyurethane</i>
③	Boccola - Bush	tecnopolimero - <i>technopolymer</i>
④ ⑩	Testate - Covers	Ø 020 ÷ 100 acciaio inox AISI 316 - <i>AISI 316 stainless steel</i> Ø 125 ÷ 200 acciaio inox AISI 304 - <i>AISI 304 stainless steel</i>
⑤	O-ring	NBR
⑥	Tubo - Tube	Ø 020 - 25 acciaio inox AISI 304 - <i>AISI 304 stainless steel</i> Ø 032 - 100 acciaio inox AISI 316 - <i>AISI 316 stainless steel</i> Ø 125 ÷ 200 acciaio inox AISI 304 - <i>AISI 304 stainless steel</i>
⑦	Pistone - Piston	alluminio - <i>aluminium</i>
⑧	Magnete - Magnet	Ø 20 ÷ 32 neodimio - <i>neodymium alloy</i> Ø 40 ÷ 200 plastoferrite - <i>rubber magnet</i>
	Tiranti - Tie rods	Ø 020 ÷ 100 acciaio inox AISI 316 - <i>AISI 316 stainless steel</i> Ø 125 ÷ 200 acciaio inox AISI 304 - <i>AISI 304 stainless steel</i>
	Viti - Screws	Ø 020 ÷ 100 acciaio inox AISI 316 - <i>AISI 316 stainless steel</i> Ø 125 ÷ 200 acciaio inox AISI 304 - <i>AISI 304 stainless steel</i>
	Dado stelo - Rod nut	Ø 20 ÷ 200 acciaio inox AISI 304 - <i>AISI 304 stainless steel</i>
	Molla - Spring	acciaio - <i>steel</i>
	Paracolpo - Bumper	poliuretano - <i>polyurethane</i>



DIAGRAMMA CARICO AMMISSIBILE

XDM

XSM

XSEM

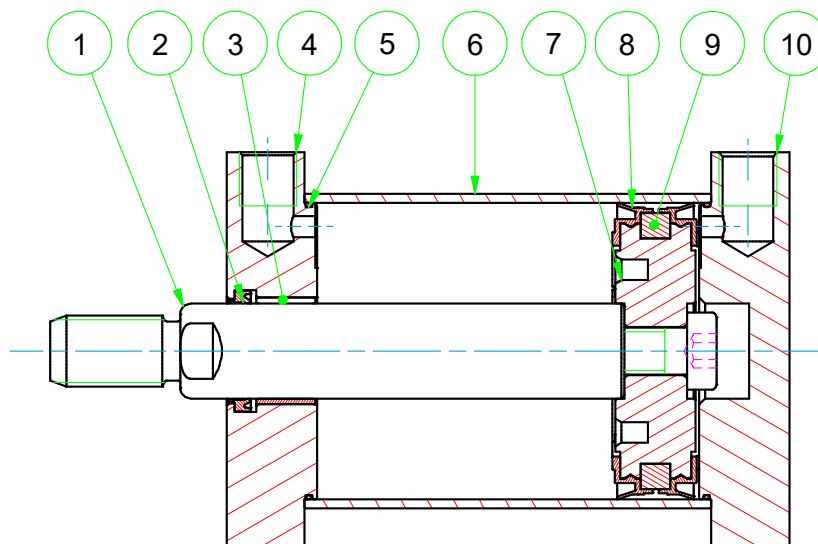
ALLOWABLE LOAD



DIAGRAMMA CARICO AMMISSIBILE

XDMA

ALLOWABLE LOAD

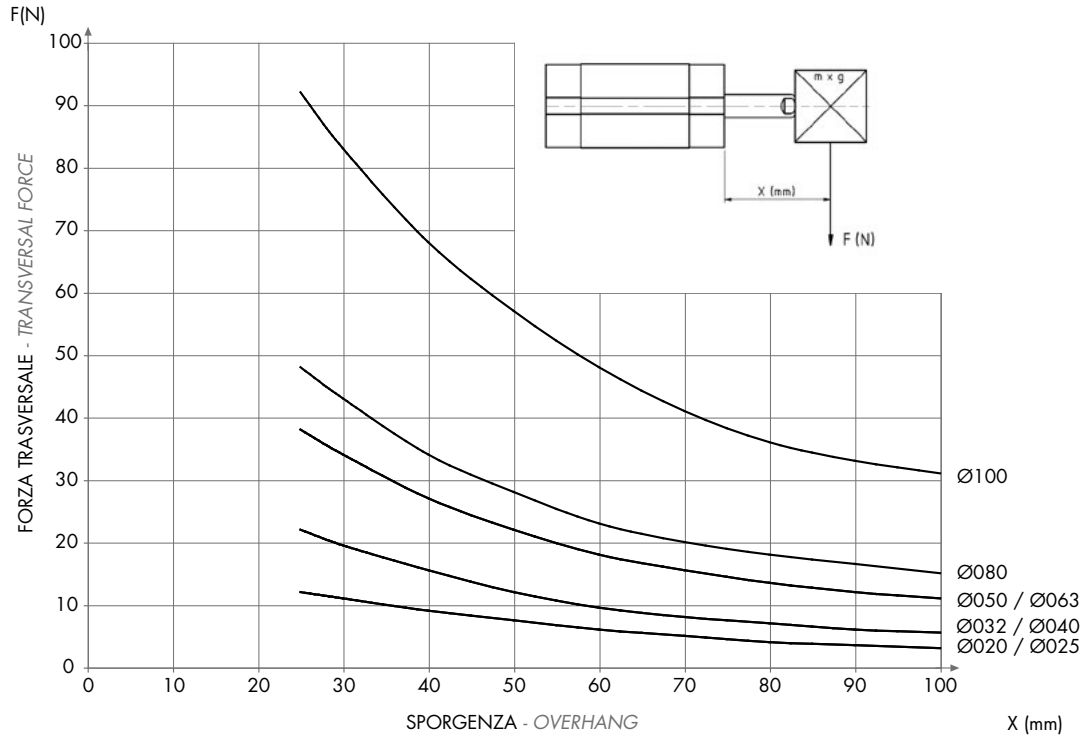
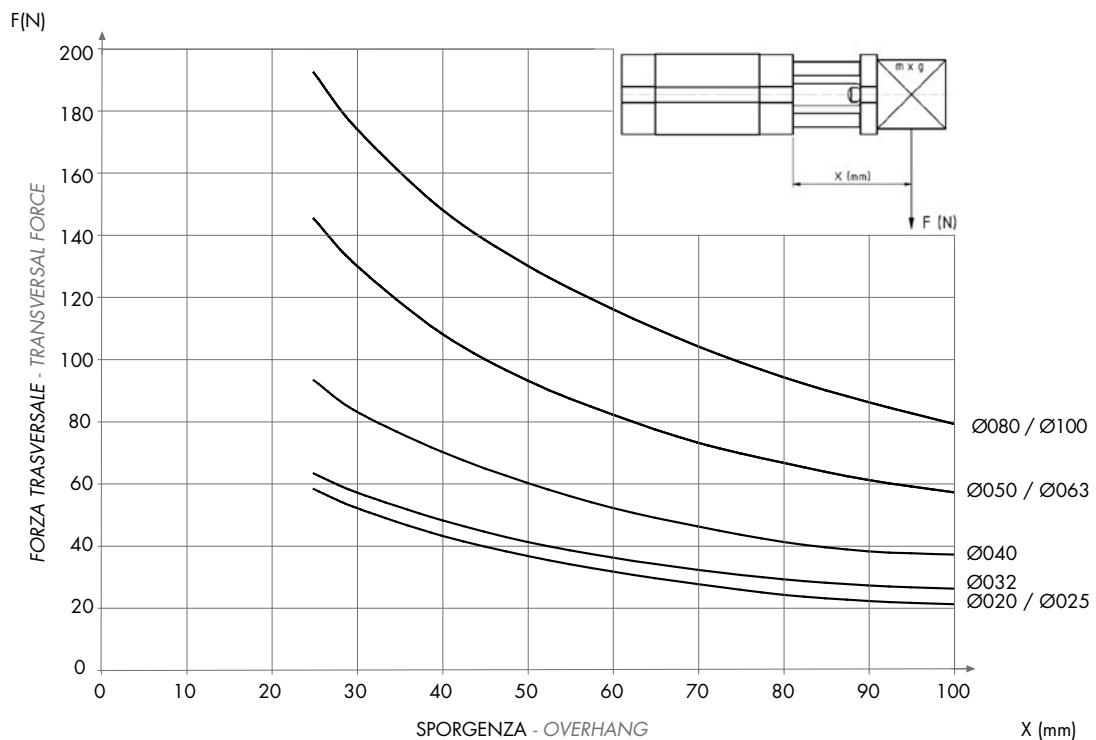

SERIE

X

DIAGRAMMA CARICO AMMISSIBILE

ALLOWABLE LOAD



DIAGRAMMA CARICO AMMISSIBILE

ALLOWABLE LOAD

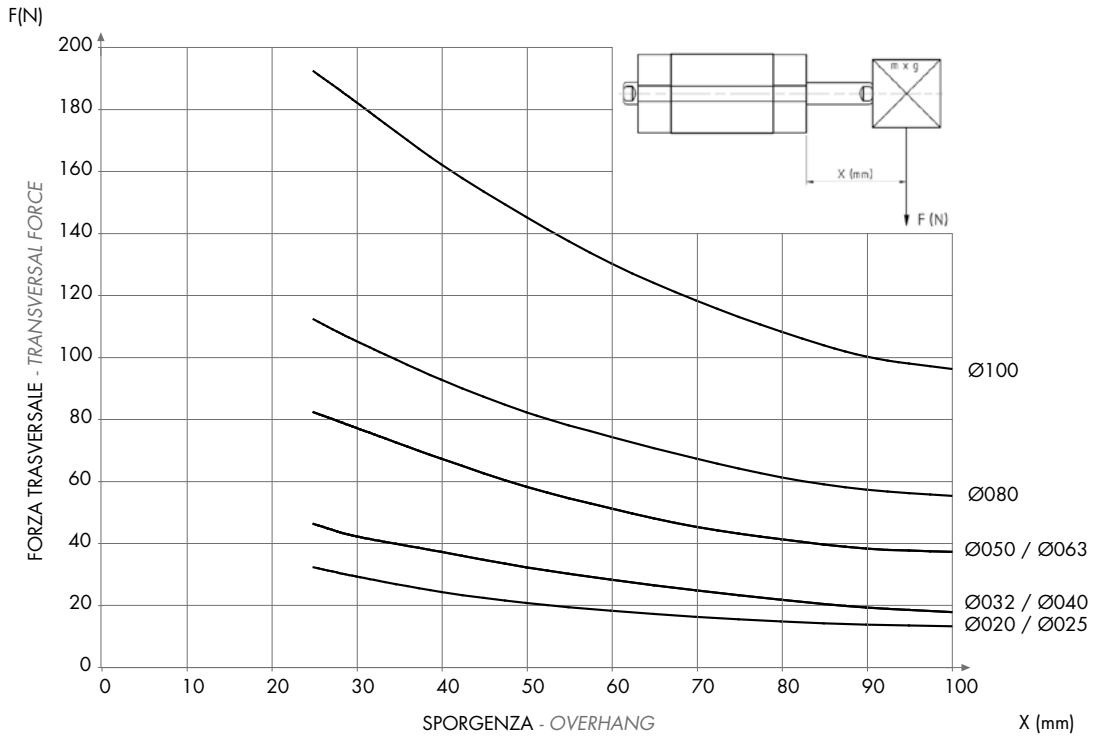
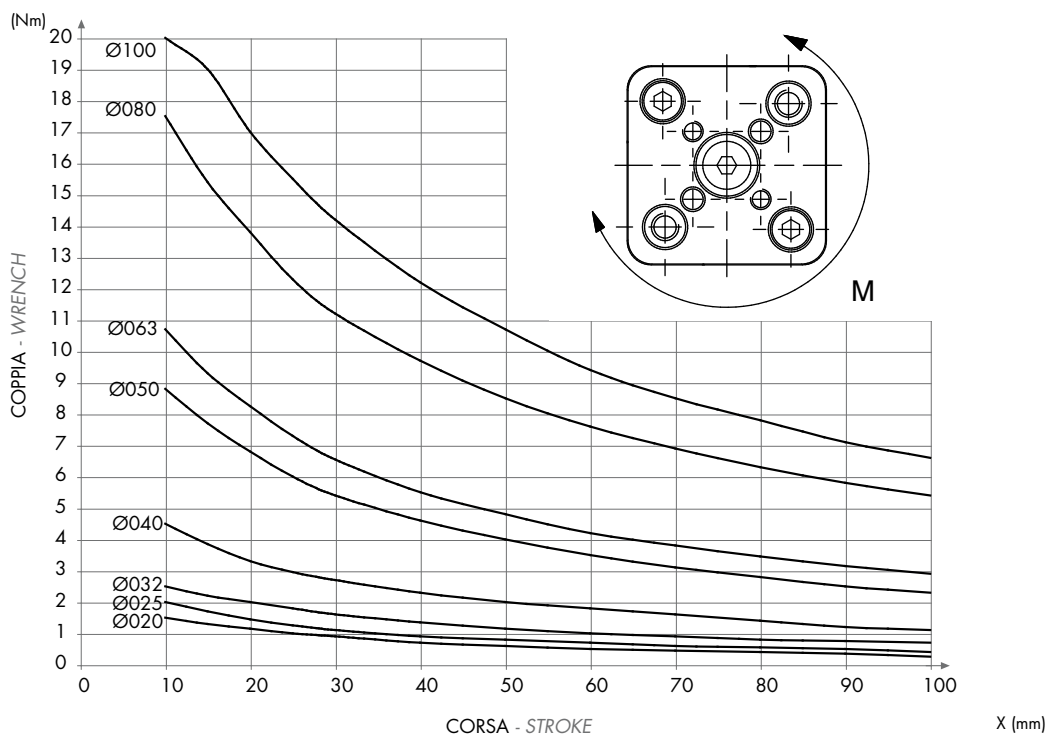

SEMPLICE EFFETTO MAGNETICO - MOLLA ANTERIORE

SINGLE ACTING MAGNETIC - FRONT SPRING

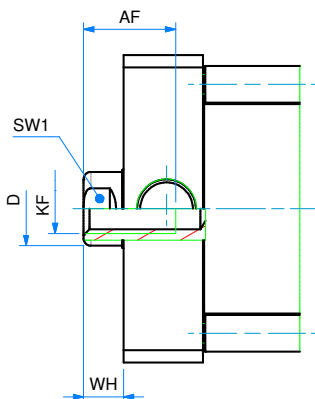
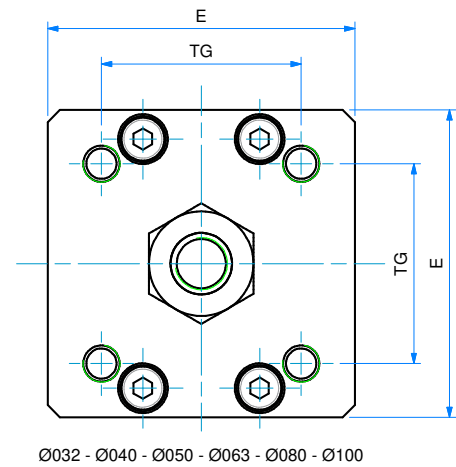
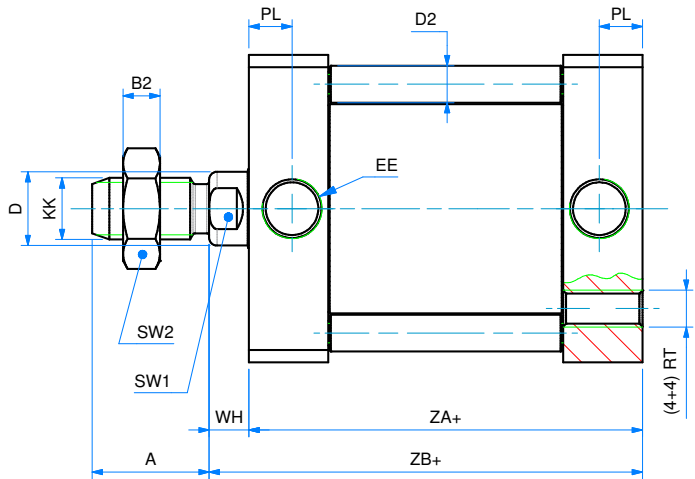
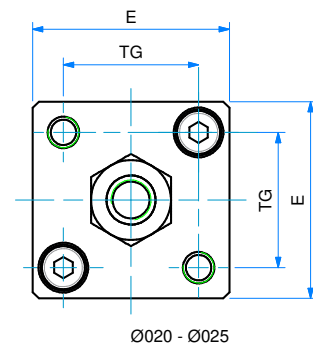
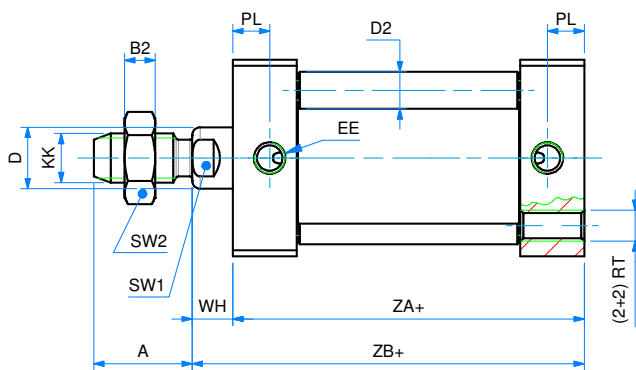
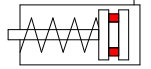

SEMPLICE EFFETTO MAGNETICO - MOLLA ANTERIORE
SINGLE ACTING MAGNETIC - FRONT SPRING

DIMENSIONI - DIMENSIONS								
Ø	020	025	032	040	050	063	080	100
A	16	16	19	19	22	22	28	28
AF	10	10	12	12	16	16	20	20
B2	5	5	6	6	7	7	8	8
Ø D	10	10	12	12	16	16	20	25
Ø D2	6	6	6	6	7	8	10	10
E	32	36	50	57	67	80	96	116
EE	M5	M5	G1/8"	G1/8"	G1/8"	G1/8"	G1/8"	G1/8"
KF	M6	M6	M8	M8	M10	M10	M12	M12
KK	M8	M8	M10x1,25	M10x1,25	M12x1,25	M12x1,25	M16x1,5	M16x1,5
PL	6	6	7	7	7	7	7,5	7,5
RT	M5	M5	M6	M6	M8	M8	M10	M10
SW1	8	8	10	10	13	13	17	22
SW2	13	13	17	17	19	19	24	24
TG	22	26	32,5	38	46,5	56,5	72	89
WH	6,5	6	6,5	7	8	8	10	10
ZA+	47*	49*	44*	45*	45*	49*	54*	67*
ZB+	53,5*	55*	50,5*	52*	53*	57*	64*	77*

+ = aggiungere lunghezza corsa (mm) - add stroke length (mm)

* per corsa - for stroke 050:

XSM 020 aggiungere / add +10 mm

XSM 025-032-040-050-063 aggiungere / add +20 mm

XSM 080-100 aggiungere / add + 30 mm

Ø	CORSE STANDARD - STANDARD STROKES
020	10 - 25 - 50
025	10 - 25 - 50
032	10 - 25 - 50
040	10 - 25 - 50
050	10 - 25 - 50
063	10 - 25 - 50
080	10 - 25 - 50
100	10 - 25 - 50

SEMPLICE EFFETTO MAGNETICO - MOLLA POSTERIORE

SINGLE ACTING MAGNETIC - REAR SPRING

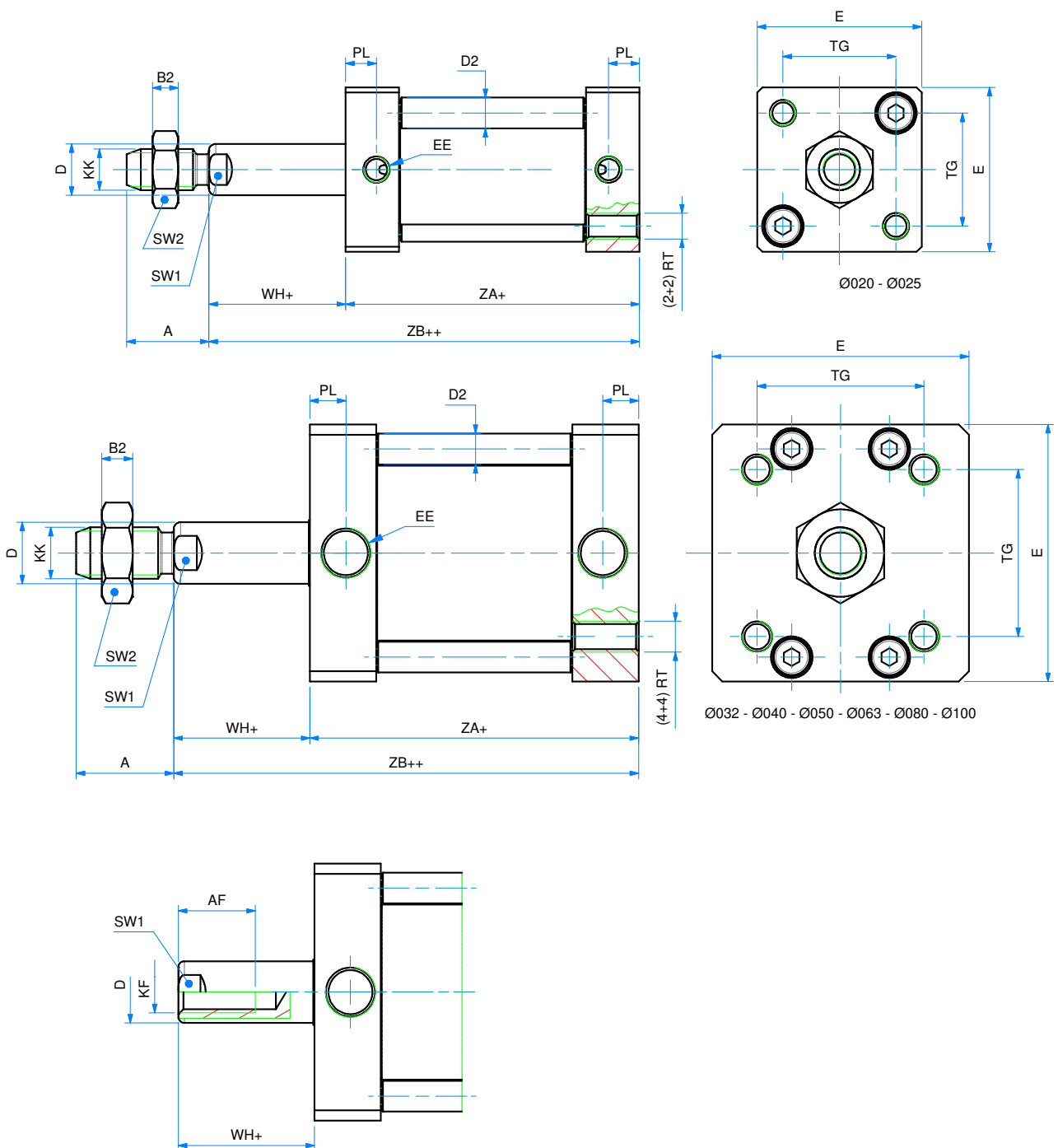
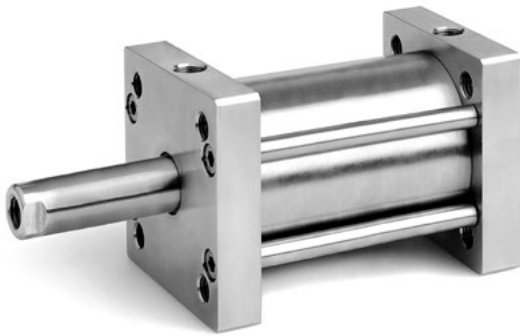
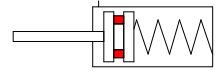

SEMPLICE EFFETTO MAGNETICO - MOLLA POSTERIORE
SINGLE ACTING MAGNETIC - REAR SPRING

DIMENSIONI - DIMENSIONS								
Ø	020	025	032	040	050	063	080	100
A	16	16	19	19	22	22	28	28
AF	10	10	12	12	16	16	20	20
B2	5	5	6	6	7	7	8	8
Ø D	10	10	12	12	16	16	20	25
Ø D2	6	6	6	6	7	8	10	10
E	32	36	50	57	67	80	96	116
EE	M5	M5	G1/8"	G1/8"	G1/8"	G1/8"	G1/8"	G1/8"
KF	M6	M6	M8	M8	M10	M10	M12	M12
KK	M8	M8	M10x1,25	M10x1,25	M12x1,25	M12x1,25	M16x1,5	M16x1,5
PL	6	6	7	7	7	7	7,5	7,5
RT	M5	M5	M6	M6	M8	M8	M10	M10
SW1	8	8	10	10	13	13	17	22
SW2	13	13	17	17	19	19	24	24
TG	22	26	32,5	38	46,5	56,5	72	89
WH+	6,5	6	6,5	7	8	8	10	10
ZA+	47*	49*	44*	45*	45*	49*	54*	67*
ZB++	53,5*	55*	50,5*	52*	53*	57*	64*	77*

* per corsa / for stroke 050:

XSEM 020-025 aggiungere / add +10 mm

XSEM 032-040-050-063 aggiungere / add +10 mm

XSEM 080-100 aggiungere / add + 20 mm

Ø	CORSE STANDARD - STANDARD STROKES
020	10 - 25 - 50
025	10 - 25 - 50
032	10 - 25 - 50
040	10 - 25 - 50
050	10 - 25 - 50
063	10 - 25 - 50
080	10 - 25 - 50
100	10 - 25 - 50

DOPPIO EFFETTO MAGNETICO

DOUBLE ACTING MAGNETIC

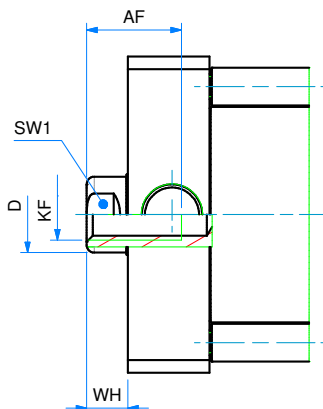
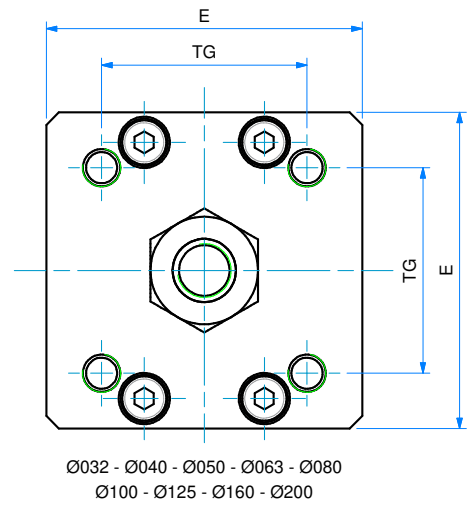
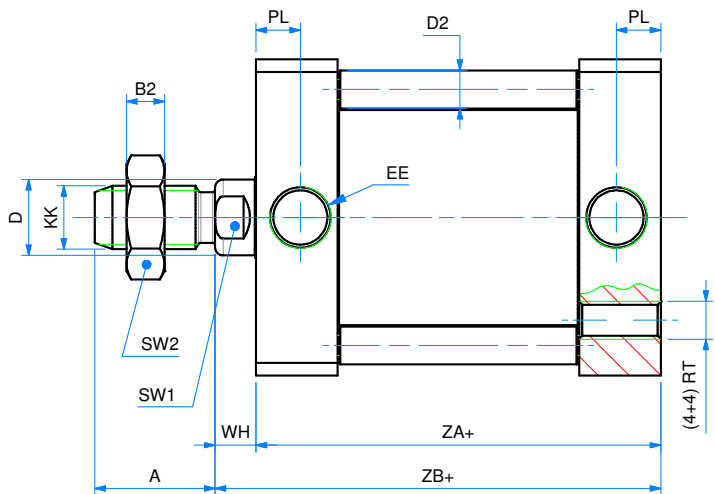
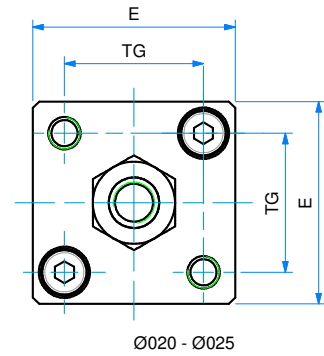
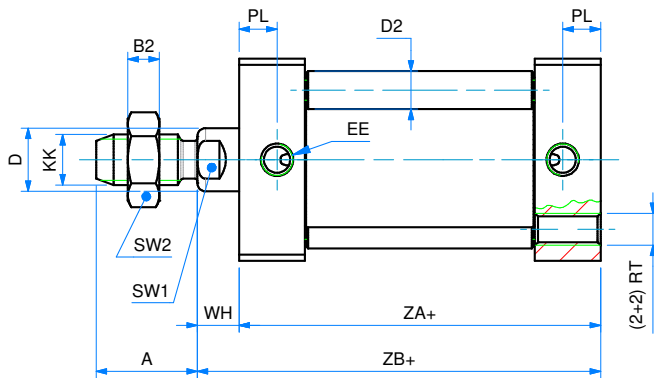
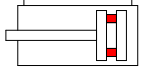

DOPPIO EFFETTO MAGNETICO
DOUBLE ACTING MAGNETIC

DIMENSIONI - DIMENSIONS											
Ø	020	025	032	040	050	063	080	100	125	160	200
A	16	16	19	19	22	22	28	28	54	72	72
AF	10	10	12	12	16	16	20	20	25	30	30
B2	5	5	6	6	7	7	8	8	12	14	14
Ø D	10	10	12	12	16	16	20	25	30	40	40
Ø D2	6	6	6	6	7	8	10	10	10	12	14
E	32	36	50	57	67	80	96	116	140	180	220
EE	M5	M5	G1/8"	G1/8"	G1/8"	G1/8"	G1/8"	G1/8"	1/4"	3/8"	3/8"
KK	M8	M8	M10x1,25	M10x1,25	M12x1,25	M12x1,25	M16x1,5	M16x1,5	M27x2	M36x2	M36x2
KF	M6	M6	M8	M8	M10	M10	M12	M12	M14	M20	M20
PL	6	6	7	7	7	7	7,5	7,5	10	12	12
RT	M5	M5	M6	M6	M8	M8	M10	M10	M12	M16	M16
SW1	8	8	10	10	13	13	17	22	28	36	36
SW2	13	13	17	17	19	19	24	24	41	55	55
TG	22	26	32,5	38	46,5	56,5	72	89	110	140	175
WH	6,5	6	6,5	7	8	8	10	10	10	12	12
ZA+	37	39	44	45	45	49	54	67	78*	87*	87*
ZB+	43,5	45	50,5	52	53	57	64	77	88*	99*	99*

+ = aggiungere lunghezza corsa (mm) - *add stroke length (mm)*

* Versione con guarnizioni per alta temperatura (VA) - *version with high temperature seals (VA)*:

Ø	125	160	200
ZA+	83	91	105
ZB+	93	103	117

Ø	CORSE STANDARD - STANDARD STROKES
020	10 - 25 - 50 - 75 - 100 - 125 - 160 - 200 - 250 - 300
025	10 - 25 - 50 - 75 - 100 - 125 - 160 - 200 - 250 - 300
032	10 - 25 - 50 - 75 - 100 - 125 - 160 - 200 - 250 - 300 - 350 - 400
040	10 - 25 - 50 - 75 - 100 - 125 - 160 - 200 - 250 - 300 - 350 - 400
050	10 - 25 - 50 - 75 - 100 - 125 - 160 - 200 - 250 - 300 - 350 - 400
063	10 - 25 - 50 - 75 - 100 - 125 - 160 - 200 - 250 - 300 - 350 - 400
080	10 - 25 - 50 - 75 - 100 - 125 - 160 - 200 - 250 - 300 - 350 - 400
100	10 - 25 - 50 - 75 - 100 - 125 - 160 - 200 - 250 - 300 - 350 - 400
125	10 - 25 - 50 - 75 - 100 - 125 - 160 - 200 - 250 - 300
160	10 - 25 - 50 - 75 - 100 - 125 - 160 - 200 - 250 - 300
200	10 - 25 - 50 - 75 - 100 - 125 - 160 - 200 - 250 - 300

DOPPIO EFFETTO MAGNETICO ANTIROTAZIONE

DOUBLE ACTING MAGNETIC ANTI-ROTATION

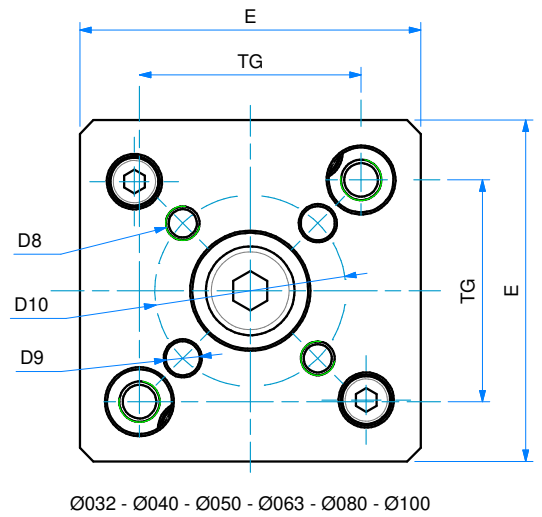
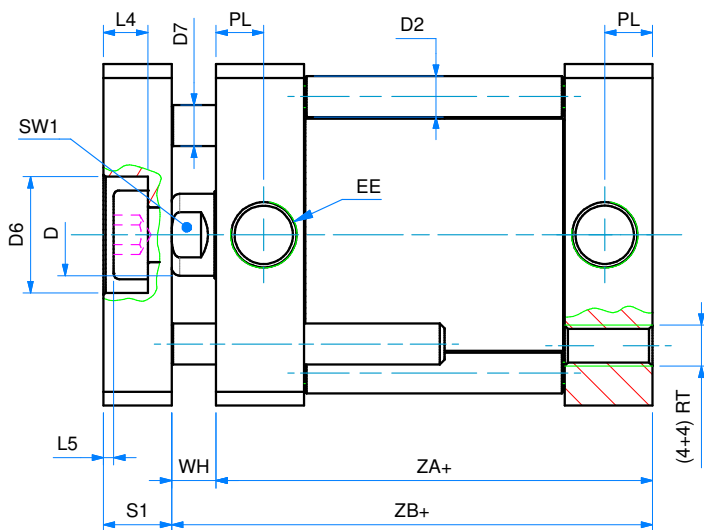
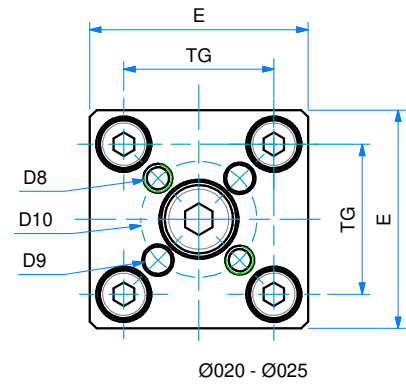
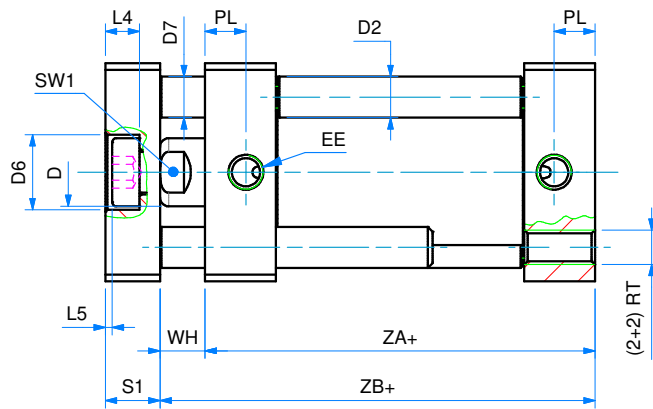
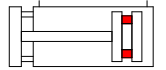

DOPPIO EFFETTO MAGNETICO ANTIROTAZIONE
DOUBLE ACTING MAGNETIC ANTI-ROTATION

DIMENSIONI - DIMENSIONS								
Ø	020	025	032	040	050	063	080	100
Ø D	10	10	12	12	16	16	20	25
Ø D2	6	6	6	6	7	8	10	10
Ø D6	11	14	17	17	22	22	28	30
Ø D7	6	6	6	8	10	10	12	14
D8	M4	M5	M5	M5	M6	M6	M8	M10
Ø D9	4	5	5	5	6	6	8	10
Ø D10	17	22	28	33	42	50	65	80
E	32	36	50	57	67	80	96	116
EE	M5	M5	G1/8	G1/8	G1/8	G1/8	G1/8	G1/8
SW1	8	8	10	10	13	13	17	22
L4	5	5	6,5	6,5	7,5	7,5	9	10
L5	1	1	1,5	1,5	1,5	1,5	2	3
PL	6	6	7	7	7	7	7,5	7,5
RT	M5	M5	M6	M6	M8	M8	M10	M10
S1	8	8	10	10	12	12	14	14
TG	22	26	32,5	38	46,5	56,5	72	89
WH	6,5	6	6,5	7	8	8	10	10
ZA+	37	39	44	45	45	49	54	67
ZB+	43,5	45	50,5	52	53	57	64	77

+ = aggiungere lunghezza corsa (mm) - add stroke length (mm)

Ø	CORSE STANDARD - STANDARD STROKES
020	10 - 25 - 50 - 75 - 100 - 125 - 160 - 200 - 250 - 300
025	10 - 25 - 50 - 75 - 100 - 125 - 160 - 200 - 250 - 300
032	10 - 25 - 50 - 75 - 100 - 125 - 160 - 200 - 250 - 300 - 350 - 400
040	10 - 25 - 50 - 75 - 100 - 125 - 160 - 200 - 250 - 300 - 350 - 400
050	10 - 25 - 50 - 75 - 100 - 125 - 160 - 200 - 250 - 300 - 350 - 400
063	10 - 25 - 50 - 75 - 100 - 125 - 160 - 200 - 250 - 300 - 350 - 400
080	10 - 25 - 50 - 75 - 100 - 125 - 160 - 200 - 250 - 300 - 350 - 400
100	10 - 25 - 50 - 75 - 100 - 125 - 160 - 200 - 250 - 300 - 350 - 400

DOPPIO EFFETTO MAGNETICO STELO PASSANTE

DOUBLE ACTING MAGNETIC WITH DOUBLE ROD

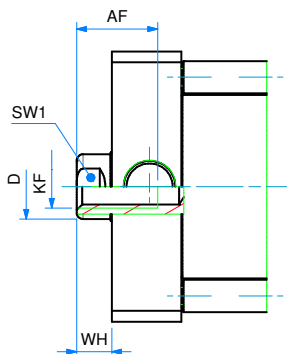
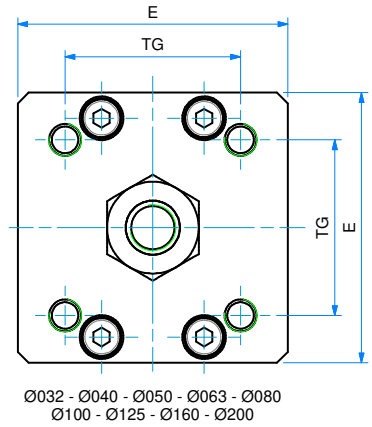
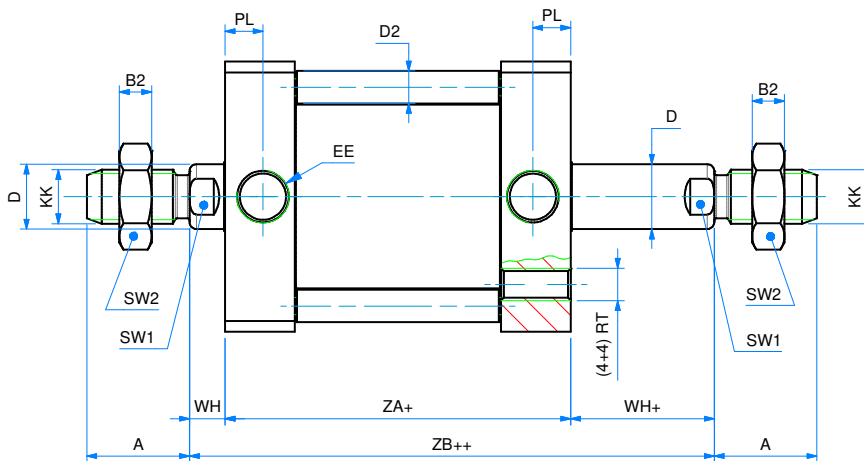
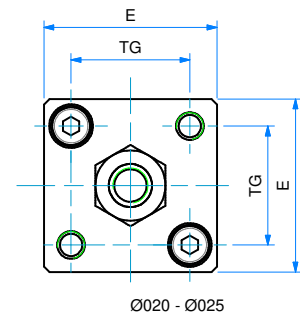
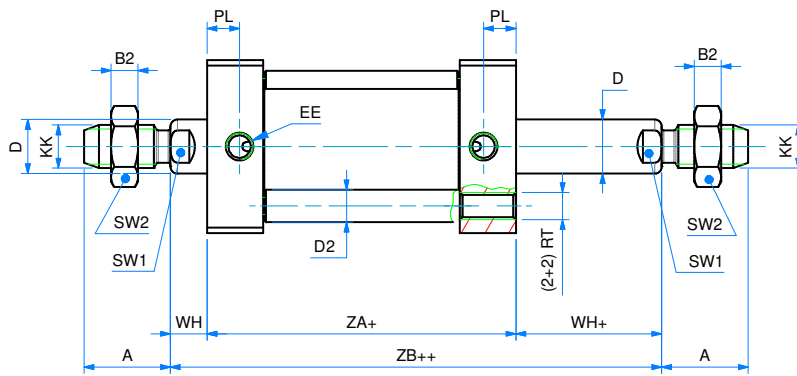
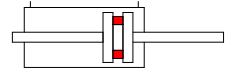

DOPPIO EFFETTO MAGNETICO STELO PASSANTE
DOUBLE ACTING MAGNETIC WITH DOUBLE ROD

DIMENSIONI - DIMENSIONS											
Ø	020	025	032	040	050	063	080	100	125	160	200
A	16	16	19	19	22	22	28	28	54	72	72
AF	10	10	12	12	16	16	20	20	25	30	30
B2	5	5	6	6	7	7	8	8	12	14	14
Ø D	10	10	12	12	16	16	20	25	30	40	40
Ø D2	6	6	6	6	7	8	10	10	10	12	14
E	32	36	50	57	67	80	96	116	140	180	220
EE	M5	M5	G1/8"	G1/8"	G1/8"	G1/8"	G1/8"	G1/8"	1/4"	3/8"	3/8"
KF	M6	M6	M8	M8	M10	M10	M12	M12	M14	M20	M20
KK	M8	M8	M10x1,25	M10x1,25	M12x1,25	M12x1,25	M16x1,5	M16x1,5	M27x2	M36x2	M36x2
PL	6	6	7	7	7	7	7,5	7,5	10	12	12
RT	M5	M5	M6	M6	M8	M8	M10	M10	M12	M16	M16
SW1	8	8	10	10	13	13	17	22	28	36	36
SW2	13	13	17	17	19	19	24	24	41	55	55
TG	22	26	32,5	38	46,5	56,5	72	89	110	140	175
WH	6,5	6	6,5	7	8	8	10	10	10	12	12
WH+	6,5	6	6,5	7	8	8	10	10	10	12	12
ZA+	37	39	44	45	45	49	54	67	78*	87*	87*
ZB++	50	51	57	59	61	65	74	87	98*	111*	111*

+ = aggiungere lunghezza corsa (mm) - *add stroke length (mm)*

* Versione con guarnizioni per alta temperatura (VA) - *version with high temperature seals (VA)*:

Ø	125	160	200
ZA+	83	91	105
ZB+	103	115	129

Ø	CORSE STANDARD - STANDARD STROKES
020	5 - 10 - 15 - 20 - 25 - 30 - 40 - 50 - 60 - 70 - 75 - 80 - 90 - 100 - 125 - 160 - 200 - 250
025	5 - 10 - 15 - 20 - 25 - 30 - 40 - 50 - 60 - 70 - 75 - 80 - 90 - 100 - 125 - 160 - 200 - 250
032	5 - 10 - 15 - 20 - 25 - 30 - 40 - 50 - 60 - 70 - 75 - 80 - 90 - 100 - 125 - 160 - 200 - 250 - 300 - 350 - 400
040	5 - 10 - 15 - 20 - 25 - 30 - 40 - 50 - 60 - 70 - 75 - 80 - 90 - 100 - 125 - 160 - 200 - 250 - 300 - 350 - 400
050	5 - 10 - 15 - 20 - 25 - 30 - 40 - 50 - 60 - 70 - 75 - 80 - 90 - 100 - 125 - 160 - 200 - 250 - 300 - 350 - 400
063	5 - 10 - 15 - 20 - 25 - 30 - 40 - 50 - 60 - 70 - 75 - 80 - 90 - 100 - 125 - 160 - 200 - 250 - 300 - 350 - 400
080	5 - 10 - 15 - 20 - 25 - 30 - 40 - 50 - 60 - 70 - 75 - 80 - 90 - 100 - 125 - 160 - 200 - 250 - 300 - 350 - 400
100	5 - 10 - 15 - 20 - 25 - 30 - 40 - 50 - 60 - 70 - 75 - 80 - 90 - 100 - 125 - 160 - 200 - 250 - 300 - 350 - 400
125	10 - 25 - 50 - 75 - 100 - 125 - 160 - 200 - 250 - 300
160	10 - 25 - 50 - 75 - 100 - 125 - 160 - 200 - 250 - 300
200	10 - 25 - 50 - 75 - 100 - 125 - 160 - 200 - 250 - 300

DOPPIO EFFETTO MAGNETICO STELO PASSANTE ANTIROTAZIONE

DOUBLE ACTING MAGNETIC ANTI-ROTATION WITH DOUBLE ROD

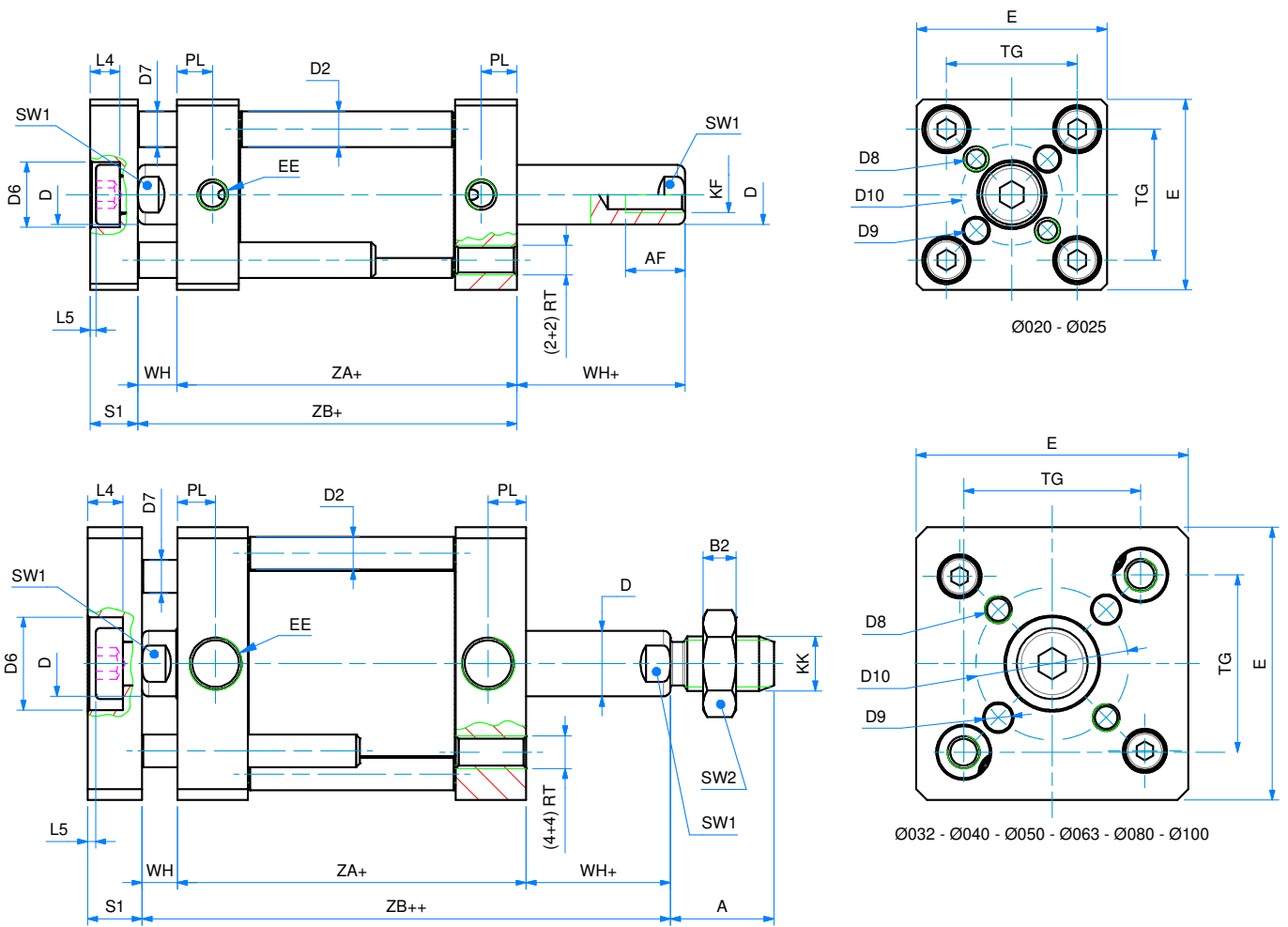
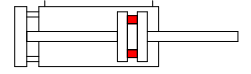

DOPPIO EFFETTO MAGNETICO STELO PASSANTE ANTIROTAZIONE
DOUBLE ACTING MAGNETIC ANTI-ROTATION WITH DOUBLE ROD

DIMENSIONI - DIMENSIONS								
Ø	020	025	032	040	050	063	080	100
A	16	16	19	19	22	22	28	28
AF	10	10	12	12	16	16	20	20
B2	5	5	6	6	7	7	8	8
Ø D	10	10	12	12	16	16	20	25
Ø D2	6	6	6	6	7	8	10	10
Ø D6	11	14	17	17	22	22	28	30
Ø D7	5	6	6	8	10	10	12	14
D8	M4	M5	M5	M5	M6	M6	M8	M10
Ø D9	4	5	5	5	6	6	8	10
Ø D10	17	22	28	33	42	50	65	80
E	32	36	50	57	67	80	96	116
EE	M5	M5	G1/8	G1/8	G1/8	G1/8	G1/8	G1/8
SW1	8	8	10	10	13	13	17	22
KF	M6	M6	M8	M8	M10	M10	M12	M12
KK	M8	M8	M10x1,25	M10x1,25	M12x1,25	M12x1,25	M16x1,5	M16x1,5
L4	5	5	6,5	6,5	7,5	7,5	9	10
L5	1	1	1,5	1,5	1,5	1,5	2	3
PL	6	6	7	7	7	7	7,5	7,5
RT	M5	M5	M6	M6	M8	M8	M10	M10
S1	8	8	10	10	12	12	14	14
TG	22	26	32,5	38	46,5	56,5	72	89
WH	6,5	6	6,5	7	8	8	10	10
WH+	6,5	6	6,5	7	8	8	10	10
ZA+	37	39	44	45	45	49	54	67
ZB++	50	51	57	59	61	65	74	87

+ = aggiungere lunghezza corsa (mm) - add stroke length (mm)

Ø	CORSE STANDARD - STANDARD STROKES
020	10 - 25 - 50 - 75 - 100 - 125 - 160 - 200 - 250 - 300
025	10 - 25 - 50 - 75 - 100 - 125 - 160 - 200 - 250 - 300
032	10 - 25 - 50 - 75 - 100 - 125 - 160 - 200 - 250 - 300 - 350 - 400
040	10 - 25 - 50 - 75 - 100 - 125 - 160 - 200 - 250 - 300 - 350 - 400
050	10 - 25 - 50 - 75 - 100 - 125 - 160 - 200 - 250 - 300 - 350 - 400
063	10 - 25 - 50 - 75 - 100 - 125 - 160 - 200 - 250 - 300 - 350 - 400
080	10 - 25 - 50 - 75 - 100 - 125 - 160 - 200 - 250 - 300 - 350 - 400
100	10 - 25 - 50 - 75 - 100 - 125 - 160 - 200 - 250 - 300 - 350 - 400

ACCESSORI DI FISSAGGIO ISO 15552 INOX (UTILIZZABILI ANCHE PER CILINDRI ISO 21287)

STAINLESS STEEL ISO 15552 MOUNTING PARTS (ALSO SUITABLE FOR ISO 21287 CYLINDERS)

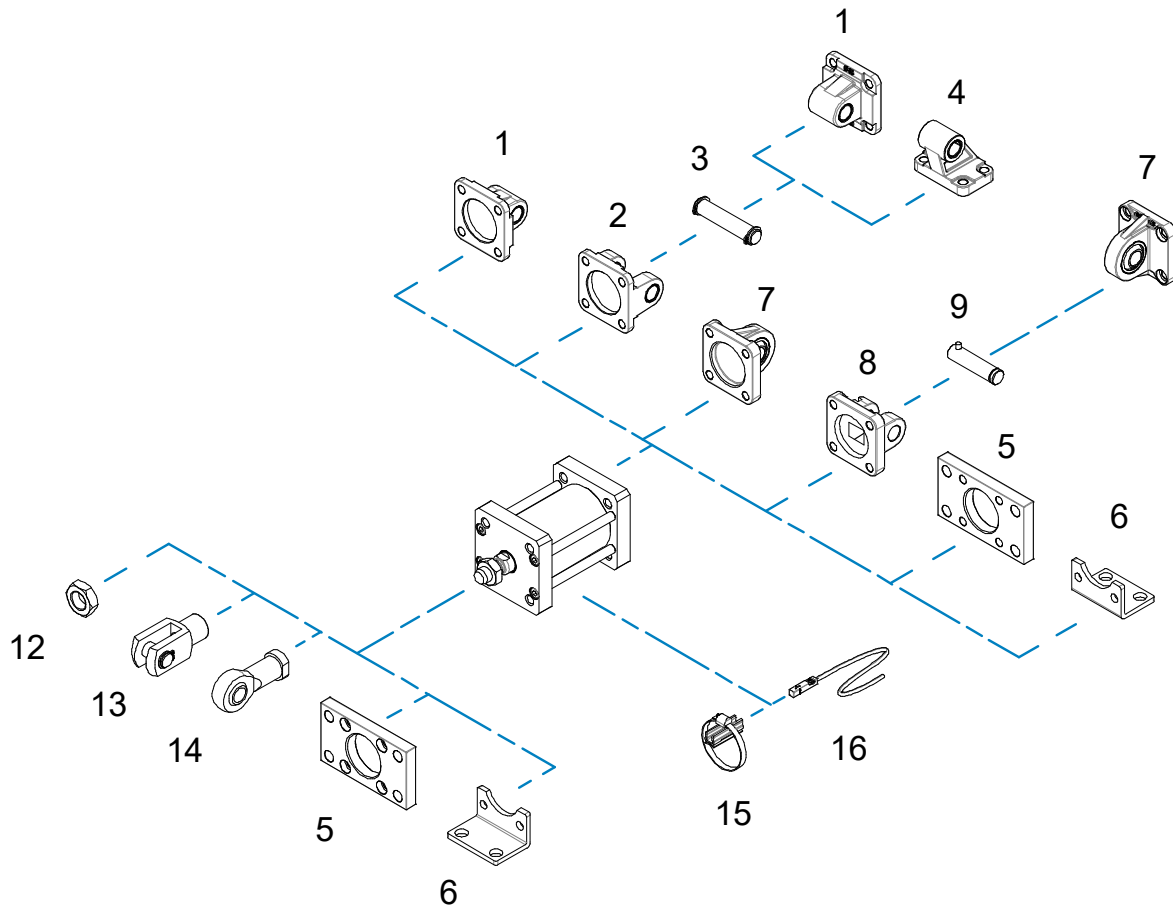

POS.	CODE	DESCRIZIONE - DESCRIPTION
1	CMI---X	cerniera maschio iso - iso male hinge
2	CFI---X	cerniera femmina iso - iso female hinge
3	PCF---X	perno per cerniera - pin for hinge
4	ASI---X	articolazione a squadra iso - iso square hinge
5	FI---X	flangia iso - iso flange
6	PBI---X	pedino basso iso - iso foot mounting
7	CMSI---X	cerniera maschio snodata iso - iso male hinge with ball joint
8	CFSI---X	cerniera femmina stretta iso - iso narrow female hinge
9	PCFS---X	perno per cerniera stretta - pin for narrow hinge
12	DA--x---X	dado - nut
13	FP--x---X	forcella con perno - clevis with pin
14	SSFi--x---X	snodo sferico - rod eye
15	36.TIRX---	adattatore sensore - sensor mounting
16	36.SEN---	sensore magnetico - magnetic sensor

Fissaggi forniti con viti - Mounting parts supplied with screws

CERNIERA MASCHIO ISO INOX (MP4)

STAINLESS STEEL ISO MALE HINGE (MP4)

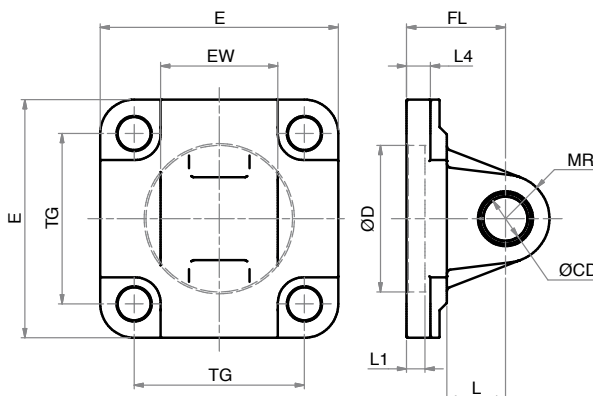

LA FORNITURA COMPRENDE:
n° 1 CERNIERA MASCHIO
n° 4 VITI
THE SUPPLY INCLUDES:
n° 1 MALE HINGE
n° 4 SCREWS

MATERIALE:
ACCIAIO INOX AISI 304
MATERIAL:
AISI 304 STAINLESS STEEL

DIMENSIONI - DIMENSIONS

COD.	CMI032X	CMI040X	CMI050X	CMI063X	CMI080X	CMI100X	CMI125X	CMI160X6
ø	32	40	50	63	80	100	125	160
E	45	52	65	75	93	110	134	180
EW	26	28	32	40	50	60	70	90
FL	22	25	27	32	36	41	50	55
L1	5	5	5	5	5	5	7	7
L	13	16	16	21	22	27	30	35
L4	5,5	5,5	6,5	6,5	10	10	10	10
ø D	30	35	40	45	45	55	60	65
ø CD	10	12	12	16	16	20	25	30
MR	10	12	12	16	16	20	25	25
TG	32,5	38	46,5	56,5	72	89	110	140

CERNIERA FEMMINA ISO INOX (MP2)

STAINLESS STEEL ISO FEMALE HINGE (MP2)

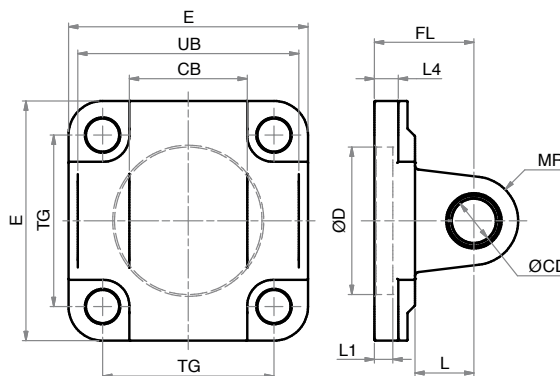

LA FORNITURA COMPRENDE:
n° 1 CERNIERA FEMMINA
n° 4 VITI
THE SUPPLY INCLUDES:
n° 1 FEMALE HINGE
n° 4 SCREWS

MATERIALE:
ACCIAIO INOX AISI 304
MATERIAL:
AISI 304 STAINLESS STEEL

DIMENSIONI - DIMENSIONS

COD.	CFI032X	CFI040X	CFI050X	CFI063X	CFI080X	CFI100X	CFI125X	CFI160X6
ø	32	40	50	63	80	100	125	160
CB	26	28	32	40	50	60	70	90
E	45	52	65	75	93	110	134	180
FL	22	25	27	32	36	41	50	55
L1	5	5	5	5	5	5	7	7
L4	5,5	5,5	6,5	6,5	10	10	10	10
L	13	16	16	21	22	27	30	35
MR	10	12	12	16	16	20	25	25
ø CD	10	12	12	16	16	20	25	30
ø D	30	35	40	45	45	55	60	65
TG	32,5	38	46,5	56,5	72	89	110	140
UB	45	52	60	70	90	110	130	170

PERNO PER CERNIERA INOX (AA4)

PCF X

STAINLESS STEEL PIN FOR HINGE (AA4)

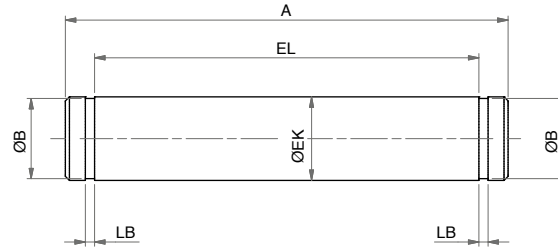

LA FORNITURA COMPRENDE:
n° 1 PERNO
n° 2 SEEGER
THE SUPPLY INCLUDES:
n° 1 PIN
n° 2 RETAINING RING

MATERIALE:
ACCIAIO INOX AISI 304
MATERIAL:
AISI 304 STAINLESS STEEL

DIMENSIONI - DIMENSIONS

COD.	PCF032X	PCF040X	PCF050X	PCF063X	PCF080X	PCF100X	PCF125X	PCF160.200X6
Ø	32	40	50	63	80	100	125	160
A	53	60	68	78	98	118	139	180
Ø B	9,6	11,5	11,5	15,2	15,2	19	23,9	28,6
EL	46	53	61	71	91	111	132	172
Ø EK	10	12	12	16	16	20	25	30
LB	1,1	1,1	1,1	1,1	1,1	1,3	1,3	1,6

ARTICOLAZIONE A SQUADRA ISO INOX (AB7)

ASI X

STAINLESS STEEL ISO SQUARE HINGE (AB7)

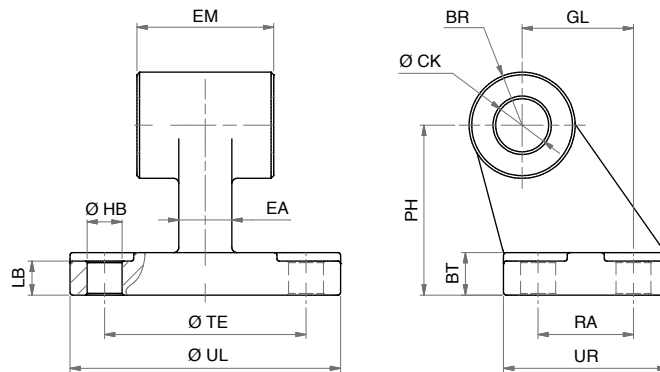

LA FORNITURA COMPRENDE:
n° 1 ARTICOLAZIONE A SQUADRA
THE SUPPLY INCLUDES:
n° 1 SQUARE HINGE

MATERIALE:
ACCIAIO INOX AISI 304
MATERIAL:
AISI 304 STAINLESS STEEL

DIMENSIONI - DIMENSIONS

COD.	ASI032X	ASI040X	ASI050X	ASI063X	ASI080X	ASI100X	ASI125X
Ø	32	40	50	63	80	100	125
BR	10	11	13	15	15	19	22,5
BT	8	10	12	14	14	17	20
CK	10	12	12	16	16	20	25
EA	10	15	16	16	20	20	30
EM	26	28	32	40	50	60	70
GL	21	24	33	37	47	55	70
LB	6,4	8,4	10,4	12,4	11,5	14,5	16,8
Ø HB	6,6	6,6	9	9	11	11	14
PH	32	36	45	50	63	71	90
RA	18	22	30	35	40	50	60
TE	38	41	50	52	66	76	94
UL	51	54	65	67	86	96	124
UR	31	35	45	50	60	70	90

FLANGIA ISO INOX (MF1 - MF2)

STAINLESS STEEL ISO FLANGE (MF1 - MF2)

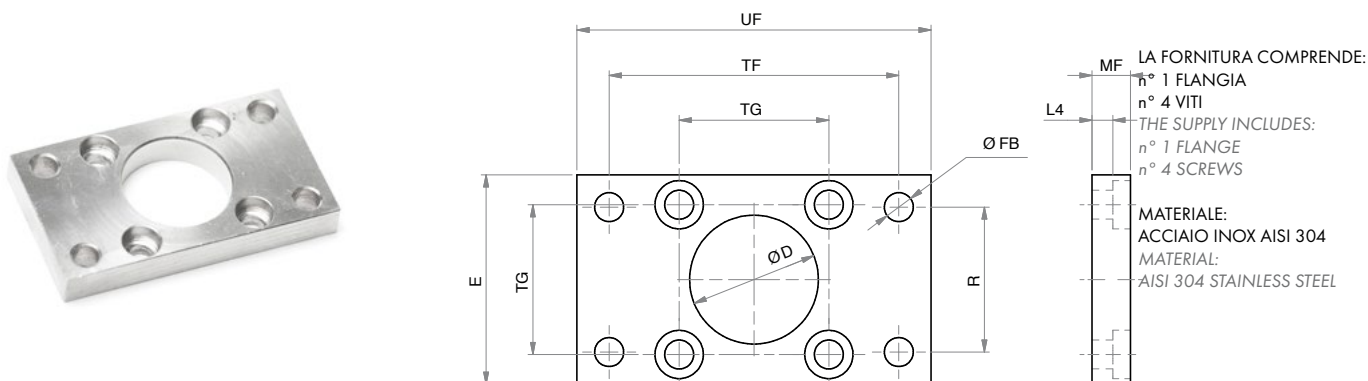

DIMENSIONI - DIMENSIONS

COD.	FI032X	FI040X	FI050X	FI063X	FI080X	FI100X	FI125X
Ø	32	40	50	63	80	100	125
E	45	52	65	75	95	115	140
L4	5	5	6,5	6,5	9	9	10,5
MF	10	10	12	12	16	16	20
Ø D	30	35	40	45	45	55	60
Ø FB	7	9	9	9	12	14	16
R	32	36	45	50	63	75	90
TF	64	72	90	100	126	150	180
TG	32,5	38	46,5	56,5	72	89	110
UF	80	90	110	120	150	170	205

PIEDINO BASSO ISO INOX (MS1)

STAINLESS STEEL ISO FOOT MOUNTING (MS1)

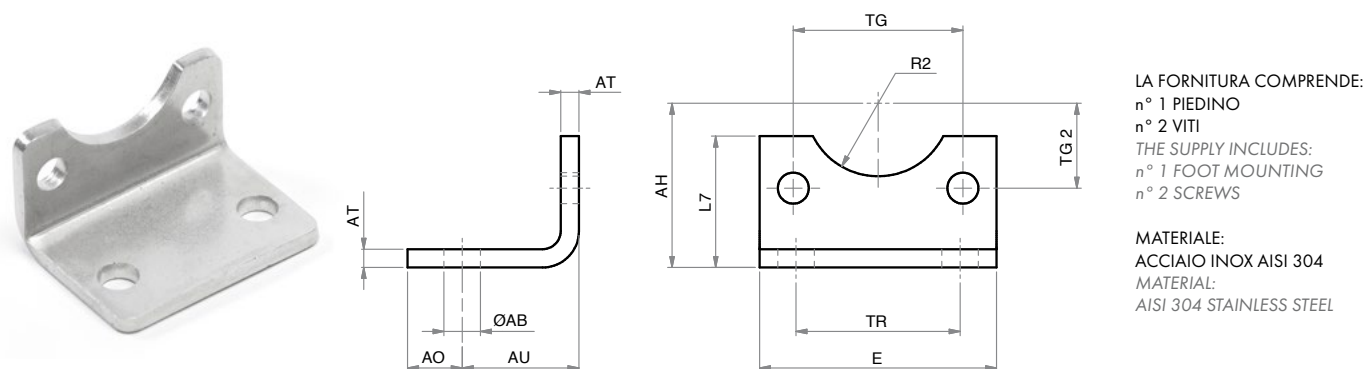

DIMENSIONI - DIMENSIONS

COD.	PBI032X	PBI040X	PBI050X	PBI063X	PBI080X	PBI100X	PBI125X
Ø	32	40	50	63	80	100	125
AH	32	36	45	50	63	71	90
AO	11	8	15	13	14	16	25
AT	4	4	5	5	6	6	8
AU	24	28	32	32	41	41	45
E	45	52	65	75	95	115	140
L7	30	30	36	35	47	53	70
Ø AB	7	10	10	10	12	14,5	16,5
R2	15	17,5	20	22,5	22,5	27,5	30
TG2	16,25	19	23,25	28,25	36	44,5	55
TG	32,5	38	46,5	56,5	72	89	110
TR	32	36	45	50	63	75	90

CERNIERA MASCHIO SNODATA ISO INOX (MP6)

STAINLESS STEEL ISO MALE HINGE WITH BALL JOINT (MP6)

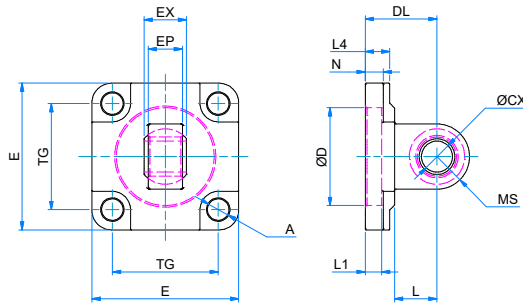

LA FORNITURA COMPRENDE:
n° 1 CERNIERA MASCHIO
n° 4 VITI
THE SUPPLY INCLUDES:
n° 1 MALE HINGE
n° 4 SCREWS

MATERIALE:
ACCIAIO INOX AISI 316
MATERIAL:
AISI 316 STAINLESS STEEL

DIMENSIONI - DIMENSIONS

COD.	CMSI032X6	CMSI040X6	CMSI050X6	CMSI063X6	CMSI080X6	CMSI100X6	CMSI125X6
Ø	32	40	50	63	80	100	125
A	6,6	6,6	9	9	11	11	13,5
DL	22	25	27	32	36	41	50
EP	10,5	12	15	15	18	18	25
EX	14	16	21	21	25	25	37
E	45	55	65	75	95	115	140
L1	5	5	5	5	5	5	7
L4	8	8	10	10	13	13	16
L	12	15	15	20	20	25	30
MS	15	18	20	23	27	30	40
N	5,5	5,5	6,5	6,5	10	10	10
ØCX	10	12	16	16	20	20	30
ØD	30	35	40	45	45	55	60
TG	32,5	38	46,5	56,5	72	89	110

CERNIERA FEMMINA STRETTA ISO INOX (AB6)

CFSI X6

STAINLESS STEEL ISO NARROW FEMALE HINGE (AB6)

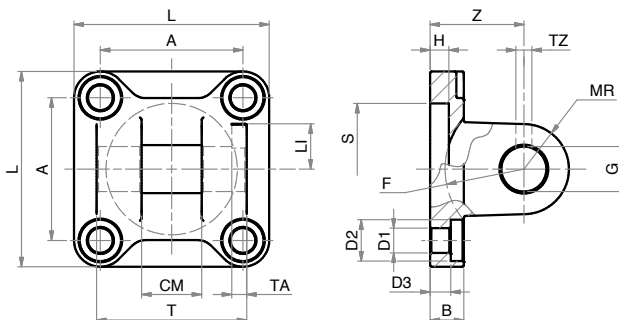

LA FORNITURA COMPRENDE:
n° 1 CERNIERA FEMMINA
n° 4 VITI
THE SUPPLY INCLUDES:
n° 1 FEMALE HINGE
n° 4 SCREWS

MATERIALE:
ACCIAIO INOX AISI 316
MATERIAL:
AISI 316 STAINLESS STEEL

DIMENSIONI - DIMENSIONS

COD.	CFSI032X6	CFSI040X6	CFSI050X6	CFSI063X6	CFSI080X6	CFSI100X6	CFSI125X6
ø	32	40	50	63	80	100	125
A	32,5	38	46,5	56,5	72	89	110
B	9	9	1	1	14	14	20
CM	14	16	21	21	25	25	37
D1	6,6	6,6	9	9	11	11	14
D2	11	11	15	15	18	18	20
D3	5,5	5,5	6,5	6,5	10	10	10
F min.	17	20	22	25	30	32	42
G	10	12	16	16	20	20	30
H	5	5	5	5	5	5	7
LI	11,5	12	14	14	16	16	24
L	45	52	65	75	95	115	140
MR	10	12	14	18	20	22	25
S	30	35	40	45	45	55	60
TA	3	4	4	4	4	4	6
TZ	3,3	4,3	4,3	4,3	4,3	6,3	6,3
T	34	40	45	51	65	75	97
Z	22	25	27	32	36	41	50

PERNO PER CERNIERA STRETTA INOX (AA6)

PCFS X6

STAINLESS STEEL PIN FOR NARROW HINGE (AA6)

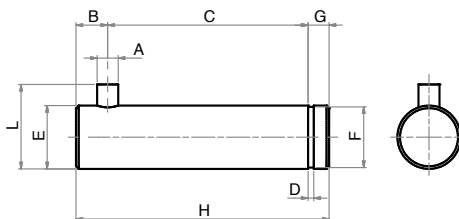

LA FORNITURA COMPRENDE:
n° 1 PERNO
n° 1 SEEGER
THE SUPPLY INCLUDES:
n° 1 PIN
n° 1 RETAINING RING

MATERIALE:
ACCIAIO INOX AISI 316
MATERIAL:
AISI 316 STAINLESS STEEL

DIMENSIONI - DIMENSIONS

COD.	PCFS032X6	PCFS040X6	PCFS050X6	PCFS063X6	PCFS080X6	PCFS100X6	PCFS125X6
ø	32	40	50	63	80	100	125
A	3	4	4	4	4	4	6
B	4,5	6	6	6	6	6	9
C	32,5	38	43	49	63	73	94
D	1,1	1,1	1,1	1,1	1,3	1,3	1,6
E	10	12	16	16	20	20	30
F	9,6	11,5	15,2	15,2	19	19	28,6
G	4	4	5	5	6	6	7
H	41	48	54	60	75	85	110
L	14	16	20	20	24	24	36

SERIE

X

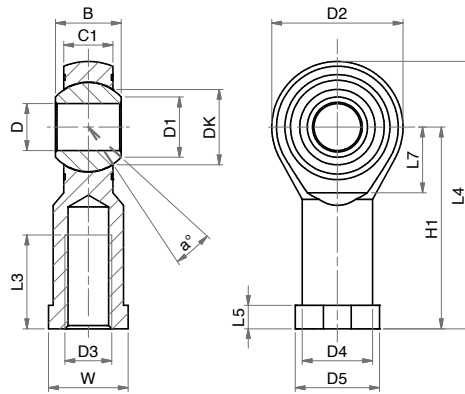
SNODO SFERICO INOX (FILETTO INTERNO)
STAINLESS STEEL ROD EYE (INTERNAL THREAD)

MATERIALE:
CORPO IN ACCIAIO
INOX AISI 304
SNODO IN ACCIAIO
INOX E PTFE
MATERIAL:
BODY IN
AISI 304 STAINLESS STEEL
EYE IN STAINLESS STEEL
AND PTFE

DIMENSIONI - DIMENSIONS

COD.	SSFI08x1,25X	SSFI10x1,25X	SSFI12x1,25X	SSFI16x1,5X	SSFI20x1,5X	SSFI27x2X	SSFI36x2X
α°	14	13	13	15	14	17	16
B	12	14	16	21	25	37	43
C1	9	10,5	12	15	18	25	28
D1	10,4	12,9	15,4	19,3	24,3	34,8	37,7
D2	24	28	32	42	50	70	80
D3	M8	M10x1,25	M12x1,25	M16x1,5	M20x1,5	M27x2	M36x2
D4	12,5	15	17,5	22	27,5	40	46
D5	16	19	22	27	34	50	58
DK	15,87	19,05	22,22	28,57	34,92	50,8	57,15
D	8	10	12	16	20	30	35
H1	36	43	50	64	77	110	125
L3	16	20	22	28	33	51	56
L4	48	57	66	85	102	145	165
L5	5	6,5	6,5	8	10	15	17
L7	13	15	17	23	27	36	41
W	14	17	19	22	30	41	50

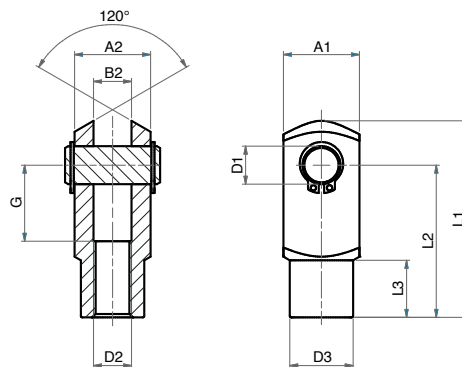
FORCELLA CON PERNO INOX
STAINLESS STEEL CLEVIS WITH PIN

MATERIALE:
ACCIAIO INOX AISI 304
MATERIAL:
AISI 304 STAINLESS STEEL

LA FORNITURA COMPRENDE:
n° 1 PERNO
n° 2 SEEGER
THE SUPPLY INCLUDES:
n° 1 PIN
n° 2 RETAINING RING

DIMENSIONI - DIMENSIONS

COD.	FP08x1,25X	FP10x1,25X	FP12x1,25X	FP16x1,5X	FP20x1,5X	FP27x2X	FP36x2X
A1	16	20	24	32	40	55	70
A2	16	20	24	32	40	55	70
B2	8	10	12	16	20	30	35
G	16	20	24	32	40	54	72
L1	42	52	62	83	105	148	188
L2	32	40	48	64	80	110	144
L3	12	15	18	24	30	38	40
\varnothing D2	M8x1,25	M10x1,25	M12x1,25	M16x1,5	M20x1,5	M27x2	M36x2
\varnothing D3	14	18	20	26	34	48	60
\varnothing D1	8	10	12	16	20	30	35

SENSORI MAGNETICI PER ZONE ASETTICHE E UMIDE

MAGNETIC SENSORS FOR ASEPTICAL AND WET AREAS

CARATTERISTICHE - CHARACTERISTICS			
CODICE - CODE		36.SEN22	36.SEN23
TIPO - TYPE		ELETTRONICO - ELECTRONIC	ELETTRONICO - ELECTRONIC
Modello elettrico - Electrical design		DC PNP	DC PNP
Funzione dell'uscita - Output		N.O.	N.O.
Tensione di esercizio - Operating voltage	[V]	10...30 DC	10...30 DC
Capacità di corrente - Current rating	[mA]	100	100
Sensibilità di reazione - Magnetic sensitivity	[mT]	2,8	2,8
Velocità di passaggio - Travel speed	[m/s]	> 10	> 10
Protezione da cortocircuito - Short-circuit proof		si - yes	si - yes
Protetto da inversione di polarità - Reverse polarity protection		si - yes	si - yes
Resistente a sovraccarico - Overload protection		si - yes	si - yes
Caduta di tensione - Voltage drop	[V]	< 2,5	< 2,5
Isteresi - Hysteresis		1,5	1,5
Riproducibilità - Repeatability	[mm]	< 0,2	< 0,2
Corrente assorbita - Current consumption	[mA]	< 10	< 10
Ritardo alla disponibilità - Power-on delay time	[ms]	< 30	< 30
Frequenza di commutazione - Switching frequency	[Hz]	> 10.000	> 10.000
Temperatura ambiente - Ambient temperature	[°C]	-25...85	-25...85
Grado/Classe di protezione - Protection		IP 65/IP 67/IP 69K, III	IP 65/IP 67/IP 69K, III
Materiale involucri - Housing material		PA - (poliammide-polyamide)	PA - (poliammide-polyamide)
Materiale eccentrico di fissaggio - Fastening clamp		inox - stainless steel	inox - stainless steel
Indicazione della funzione Stato di commutazione Function display Switching status	LED	giallo - yellow	giallo - yellow
Collegamento - Connection		cavo PVC - PVC cable 3x0,14 mm ²	cavo PVC - PVC cable connettore M12 - M12 connector
Lunghezza cavo - Cable length		6 m	0,3 m
Peso - Weight		[g] 95,5	20,9

Accessori inclusi - Accessories included: Segnaposto in gomma, fascetta fermacavo - Rubber placeholder, cable clip

FASCETTA DI FISSAGGIO

36.TIRX

FIXING CLAMP

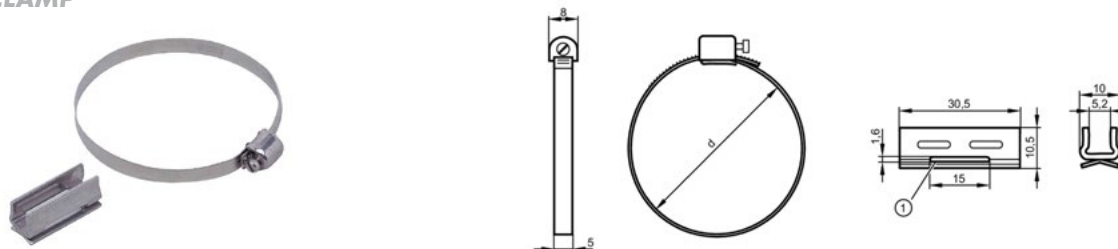

DIMENSIONI DIMENSIONS							
COD.	36.TIRX16.20	36.TIRX25.32	36.TIRX40	36.TIRX50	36.TIRX63	36.TIRX80	36.TIRX100
ø	020	025-032	040	050	063	080	100
d [mm]	18÷29	28÷39	38÷49	48÷59	58÷69	78÷89	98÷109
Materiale fascetta Fixing clamp material			acciaio inox AISI 303 - AISI 303 stainless steel				
Materiale adattatore Adapter material			acciaio inox AISI 304 - AISI 304 stainless steel				

SERIE

X

CONTATTO PNP (3 FILI)

PNP CONTACT (3 WIRES)



1= ECCENTRICO DI FISSAGGIO - FASTENING CLAMP
2= SUPERFICIE ATTIVA - SENSING FACE

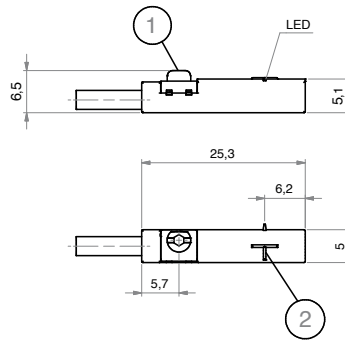

CABLAGGIO - WIRING

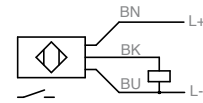

BK= NERO - BLACK
BN= MARRONE - BROWN
BU= BLU - BLUE

CONTATTO PNP (CONNETTORE M12)

PNP CONTACT (M12 CONNECTOR)



1= ECCENTRICO DI FISSAGGIO - FASTENING CLAMP
2= SUPERFICIE ATTIVA - SENSING FACE

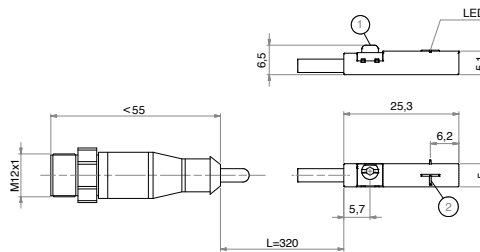

CABLAGGIO - WIRING

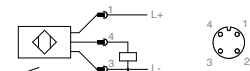

BK= NERO - BLACK
BN= MARRONE - BROWN
BU= BLU - BLUE

CAVO PROLUNGA (CONNETTORE M12)

EXTENSION CABLE (M12 CONNECTOR)

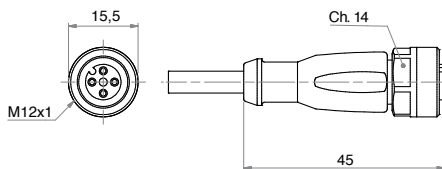

CABLAGGIO - WIRING

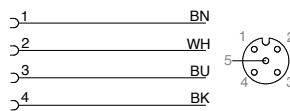

BK= NERO - BLACK
BN= MARRONE - BROWN
BU= BLU - BLUE
WH= BIANCO - WHITE

DIMENSIONI - DIMENSIONS	36.CAVX2. M12	36.CAVX5. M12
Modello elettrico - Electrical design	AC/DC	AC/DC
Tensione di esercizio - Operating voltage [V]	250 AC / 300 DC	250 AC / 300 DC
Capacità di corrente - Current rating [A]	4	4
Modello - Design	diritto - straight	diritto - straight
Temperatura ambiente - Ambient temperature [°C]	-25...90 (cRUus:max 50°C)	-25...90 (cRUus:max 50°C)
Grado/Classe di protezione - Protection	IP 67 / IP 68 / IP 69K, II	IP 67 / IP 68 / IP 69K, II
Materiale corpo - Body material: Involucro - Housing	TPU arancione - orange TPU	TPU arancione - orange TPU
Guarnizione - Sealing	viton	viton
Materiale dado - Nut material	ottone nichelato - nickel-plated brass	ottone nichelato - nickel-plated brass
Coppia di serraggio per nodo nocciolo - Tightening torque for knurled nut [Nm]	0,6...1,5	0,6...1,5
Collegamento - Connection	cavo PUR - PUR cable / 2 m; 4 x 0,34 mm ² (42 x Ø 0,1 mm); Ø 4,9 mm; senza alogeno - alogen free	cavo PUR - PUR cable / 5 m; 4 x 0,34 mm ² (42 x Ø 0,1 mm); Ø 4,9 mm; senza alogeno - alogen free
Colore della guaina - Sheath colour	nero - black	nero - black

AIR

THE BEST WAY TO



ARTEC SRL Via B. Zallone, 24

44042 CENTO (FE) - ITALY

☎ +39 051 683 62 20

☎ +39 051 683 08 82

✉ info@artec-pneumatic.com

🌐 www.artec-pneumatic.com



AZIENDA CON SISTEMA
DI GESTIONE QUALITÀ
CERTIFICATO ISO 9001:2015

PARTNER IN THE U.S.A & CANADA



W.C. Branham, Inc.

398 Troy Street

River Falls, WI 54022

☎ 800-428-1974 (Toll-free US & Canada)

715-426-2000 (Main)

☎ 715-426-1400

✉ AskWCB@wcbranham.com

🌐 www.wcbranham.com